



Standard Test Methods for DC Resistance or Conductance of Insulating Materials¹

This standard is issued under the fixed designation D 257; the number immediately following the designation indicates the year of original adoption or, in the case of revision, the year of last revision. A number in parentheses indicates the year of last approval. A superscript epsilon (ϵ) indicates an editorial change since the last revision or reapproval.

This standard has been approved for use by agencies of the Department of Defense.

1. Scope

1.1 These test methods cover direct-current procedures for the determination of dc insulation resistance, volume resistance, volume resistivity, surface resistance, and surface resistivity of electrical insulating materials, or the corresponding conductances and conductivities.

1.2 These test methods are not suitable for use in measuring the electrical resistivity/conductivity of moderately conductive materials. Use Test Method D 4496 to evaluate such materials.

1.3 The test methods and procedures appear in the following sections:

Test Method or Procedure	Section
Calculation	13
Choice of Apparatus and Test Method	7
Cleaning Solid Specimens	10.1
Conditioning of Specimens	11
Effective Area of Guarded Electrode	X2
Electrode Systems	6
Factors Affecting Insulation Resistance or Conductance Measurements	X1
Humidity Control	11.2
Liquid Specimens and Cells	9.4
Precision and Bias	15
Procedure for the Measurement of Resistance or Conductance	12
Referenced Documents	2
Report	14
Sampling	8
Significance and Use	5
Specimen Mounting	10
Summary of Test Methods	4
Terminology	3
Test Specimens for Insulation, Volume, and Surface Resistance or Conductance Determination	9
Typical Measurement Methods	X3

1.4 *This standard does not purport to address all of the safety concerns, if any, associated with its use. It is the responsibility of the user of this standard to establish appropriate safety and health practices and determine the applicability of regulatory limitations prior to use.* For a specific hazard statement, see 6.1.8.

2. Referenced Documents

2.1 ASTM Standards:

- D 150 Test Methods for AC Loss Characteristics and Permittivity Dielectric Constant of Solid Electrical Insulation²
- D 374 Test Methods for Thickness of Solid Electrical Insulation²
- D 618 Practice for Conditioning Plastics for Testing³
- D 1169 Test Method for Specific Resistance (Resistivity) of Electrical Insulating Liquids⁴
- D 1711 Terminology Relating to Electrical Insulation²
- D 4496 Test Method for DC Resistance or Conductance of Moderately Conductive Materials⁵
- D 5032 Practice for Maintaining Constant Relative Humidity by Means of Aqueous Glycerin Solutions⁵
- E 104 Practice for Maintaining Constant Relative Humidity by Means of Aqueous Solutions⁶

3. Terminology

3.1 *Definitions*—The following definitions are taken from Terminology D 1711 and apply to the terms used in these test methods.

3.1.1 *conductance, insulation, n*—the ratio of the total volume and surface current between two electrodes (on or in a specimen) to the dc voltage applied to the two electrodes.

3.1.1.1 *Discussion*—Insulation conductance is the reciprocal of insulation resistance.

3.1.2 *conductance, surface, n*—the ratio of the current between two electrodes (on the surface of a specimen) to the dc voltage applied to the electrodes.

3.1.2.1 *Discussion*—(Some volume conductance is unavoidably included in the actual measurement.) Surface conductance is the reciprocal of surface resistance.

3.1.3 *conductance, volume, n*—the ratio of the current in the volume of a specimen between two electrodes (on or in the specimen) to the dc voltage applied to the two electrodes.

¹ These test methods are under the jurisdiction of ASTM Committee D-9 on Electrical and Electronic Insulating Materials and are the direct responsibility of Subcommittee D09.12 on Electrical Tests.

Current edition approved Oct. 10, 1999. Published November 1999. Originally published as D 257 – 25 T. Last previous edition D 257 – 93 (1998).

² *Annual Book of ASTM Standards*, Vol 10.01.

³ *Annual Book of ASTM Standards*, Vol 08.01.

⁴ *Annual Book of ASTM Standards*, Vol 10.03.

⁵ *Annual Book of ASTM Standards*, Vol 10.02.

⁶ *Annual Book of ASTM Standards*, Vol 11.03.

3.1.3.1 *Discussion*—Volume conductance is the reciprocal of volume resistance.

3.1.4 *conductivity, surface, n* —the surface conductance multiplied by that ratio of specimen surface dimensions (distance between electrodes divided by the width of electrodes defining the current path) which transforms the measured conductance to that obtained if the electrodes had formed the opposite sides of a square.

3.1.4.1 *Discussion*—Surface conductivity is expressed in siemens. It is popularly expressed as siemens/square (the size of the square is immaterial). Surface conductivity is the reciprocal of surface resistivity.

3.1.5 *conductivity, volume, n* —the volume conductance multiplied by that ratio of specimen volume dimensions (distance between electrodes divided by the cross-sectional area of the electrodes) which transforms the measured conductance to that conductance obtained if the electrodes had formed the opposite sides of a unit cube.

3.1.5.1 *Discussion*—Volume conductivity is usually expressed in siemens/centimetre or in siemens/metre and is the reciprocal of volume resistivity.

3.1.6 *moderately conductive, adj*—describes a solid material having a volume resistivity between 1 and 10 000 000 Ω -cm.

3.1.7 *resistance, insulation, (R_i), n* —the ratio of the dc voltage applied to two electrodes (on or in a specimen) to the total volume and surface current between them.

3.1.7.1 *Discussion*—Insulation resistance is the reciprocal of insulation conductance.

3.1.8 *resistance, surface, (R_s), n* —the ratio of the dc voltage applied to two electrodes (on the surface of a specimen) to the current between them.

3.1.8.1 *Discussion*—(Some volume resistance is unavoidably included in the actual measurement.) Surface resistance is the reciprocal of surface conductance.

3.1.9 *resistance, volume, (R_v), n* —the ratio of the dc voltage applied to two electrodes (on or in a specimen) to the current in the volume of the specimen between the electrodes.

3.1.9.1 *Discussion*—Volume resistance is the reciprocal of volume conductance.

3.1.10 *resistivity, surface, (ρ_s), n* —the surface resistance multiplied by that ratio of specimen surface dimensions (width of electrodes defining the current path divided by the distance between electrodes) which transforms the measured resistance to that obtained if the electrodes had formed the opposite sides of a square.

3.1.10.1 *Discussion*—Surface resistivity is expressed in ohms. It is popularly expressed also as ohms/square (the size of the square is immaterial). Surface resistivity is the reciprocal of surface conductivity.

3.1.11 *resistivity, volume, (ρ_v), n* —the volume resistance multiplied by that ratio of specimen volume dimensions (cross-sectional area of the specimen between the electrodes divided by the distance between electrodes) which transforms the measured resistance to that resistance obtained if the electrodes had formed the opposite sides of a unit cube.

3.1.11.1 *Discussion*—Volume resistivity is usually expressed in ohm-centimetres (preferred) or in ohm-metres. Volume resistivity is the reciprocal of volume conductivity.

4. Summary of Test Methods

4.1 The resistance or conductance of a material specimen or of a capacitor is determined from a measurement of current or of voltage drop under specified conditions. By using the appropriate electrode systems, surface and volume resistance or conductance may be measured separately. The resistivity or conductivity can then be calculated when the required specimen and electrode dimensions are known.

5. Significance and Use

5.1 Insulating materials are used to isolate components of an electrical system from each other and from ground, as well as to provide mechanical support for the components. For this purpose, it is generally desirable to have the insulation resistance as high as possible, consistent with acceptable mechanical, chemical, and heat-resisting properties. Since insulation resistance or conductance combines both volume and surface resistance or conductance, its measured value is most useful when the test specimen and electrodes have the same form as is required in actual use. Surface resistance or conductance changes rapidly with humidity, while volume resistance or conductance changes slowly although the final change may eventually be greater.

5.2 Resistivity or conductivity may be used to predict, indirectly, the low-frequency dielectric breakdown and dissipation factor properties of some materials. Resistivity or conductivity is often used as an indirect measure of moisture content, degree of cure, mechanical continuity, and deterioration of various types. The usefulness of these indirect measurements is dependent on the degree of correlation established by supporting theoretical or experimental investigations. A decrease of surface resistance may result either in an increase of the dielectric breakdown voltage because the electric field intensity is reduced, or a decrease of the dielectric breakdown voltage because the area under stress is increased.

5.3 All the dielectric resistances or conductances depend on the length of time of electrification and on the value of applied voltage (in addition to the usual environmental variables). These must be known to make the measured value of resistance or conductance meaningful.

5.4 Volume resistivity or conductivity can be used as an aid in designing an insulator for a specific application. The change of resistivity or conductivity with temperature and humidity may be great (**1, 2, 3, 4**),⁷ and must be known when designing for operating conditions. Volume resistivity or conductivity determinations are often used in checking the uniformity of an insulating material, either with regard to processing or to detect conductive impurities that affect the quality of the material and that may not be readily detectable by other methods.

5.5 Volume resistivities above 10^{21} Ω -cm (10^{19} Ω -m), obtained on specimens under usual laboratory conditions, are of

⁷ The boldface numbers in parentheses refer to the list of references appended to these test methods.

doubtful validity, considering the limitations of commonly used measuring equipment.

5.6 Surface resistance or conductance cannot be measured accurately, only approximated, because some degree of volume resistance or conductance is always involved in the measurement. The measured value is also affected by the surface contamination. Surface contamination, and its rate of accumulation, is affected by many factors including electrostatic charging and interfacial tension. These, in turn, may affect the surface resistivity. Surface resistivity or conductivity can be considered to be related to material properties when contamination is involved but is not a material property in the usual sense.

6. Electrode Systems

6.1 The electrodes for insulating materials should be of a material that is readily applied, allows intimate contact with the specimen surface, and introduces no appreciable error because of electrode resistance or contamination of the specimen (5). The electrode material should be corrosion-resistant under the conditions of test. For tests of fabricated specimens such as feed-through bushings, cables, etc., the electrodes employed are a part of the specimen or its mounting. Measurements of insulation resistance or conductance, then, include the contaminating effects of electrode or mounting materials and are generally related to the performance of the specimen in actual use.

6.1.1 *Binding-Post and Taper-Pin Electrodes*, Fig. 1 and Fig. 2, provide a means of applying voltage to rigid insulating materials to permit an evaluation of their resistive or conductive properties. These electrodes simulate to some degree the actual conditions of use, such as binding posts on instrument panels and terminal strips. In the case of laminated insulating materials having high-resin-content surfaces, somewhat lower insulation resistance values may be obtained with taper-pin than with binding posts, due to more intimate contact with the body of the insulating material. Resistance or conductance values obtained are highly influenced by the individual contact between each pin and the dielectric material, the surface roughness of the pins, and the smoothness of the hole in the dielectric material. Reproducibility of results on different specimens is difficult to obtain.

6.1.2 *Metal Bars* in the arrangement of Fig. 3 were primarily devised to evaluate the insulation resistance or conduc-

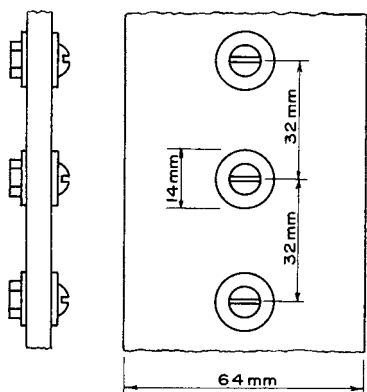
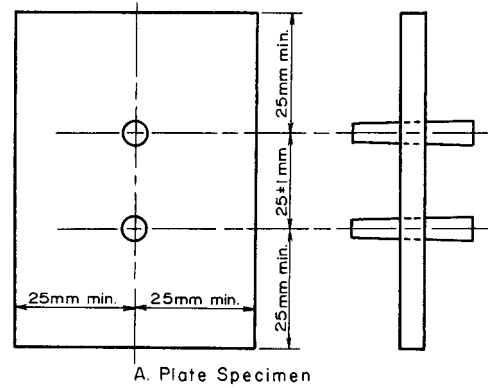
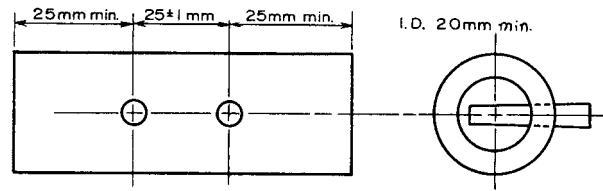

FIG. 1 Binding-Post Electrodes for Flat, Solid Specimens



A. Plate Specimen



B. Tube Specimen

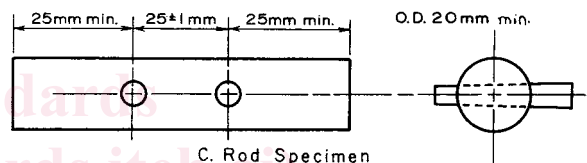

C. Rod Specimen

Use Pratt & Whitney No. 3 Taper Pins

FIG. 2 Taper-Pin Electrodes

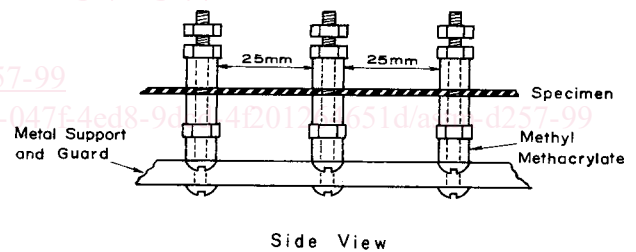

Side View

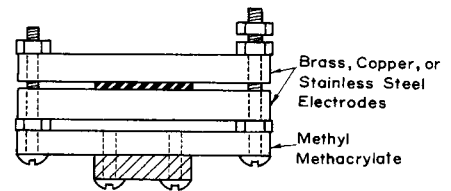

End View

FIG. 3 Strip Electrodes for Tapes and Flat, Solid Specimens

tance of flexible tapes and thin, solid specimens as a fairly simple and convenient means of electrical quality control. This arrangement is somewhat more satisfactory for obtaining approximate values of surface resistance or conductance when the width of the insulating material is much greater than its thickness.

6.1.3 *Silver Paint*, Fig. 4, Fig. 5, and Fig. 6, is available commercially with a high conductivity, either air-drying or low-temperature-baking varieties, which are sufficiently porous to permit diffusion of moisture through them and thereby allow the test specimen to be conditioned after the application of the electrodes. This is a particularly useful feature in studying resistance-humidity effects, as well as change with temperature. However, before conductive paint is used as an electrode material, it should be established that the solvent in the paint does not attack the material so as to change its electrical properties. Reasonably smooth edges of guard electrodes may be obtained with a fine-bristle brush. However, for circular electrodes, sharper edges can be obtained by the use of a ruling compass and silver paint for drawing the outline circles of the electrodes and filling in the enclosed areas by brush. A narrow strip of masking tape may be used, provided the pressure-sensitive adhesive used does not contaminate the surface of the specimen. Clamp-on masks also may be used if the electrode paint is sprayed on.

6.1.4 *Sprayed Metal*, Fig. 4, Fig. 5, and Fig. 6, may be used if satisfactory adhesion to the test specimen can be obtained. Thin sprayed electrodes may have certain advantages in that they are ready for use as soon as applied. They may be sufficiently porous to allow the specimen to be conditioned, but this should be verified. Narrow strips of masking tape or clamp-on masks must be used to produce a gap between the guarded and the guard electrodes. The tape shall be such as not to contaminate the gap surface.

6.1.5 *Evaporated Metal* may be used under the same conditions given in 6.1.4.

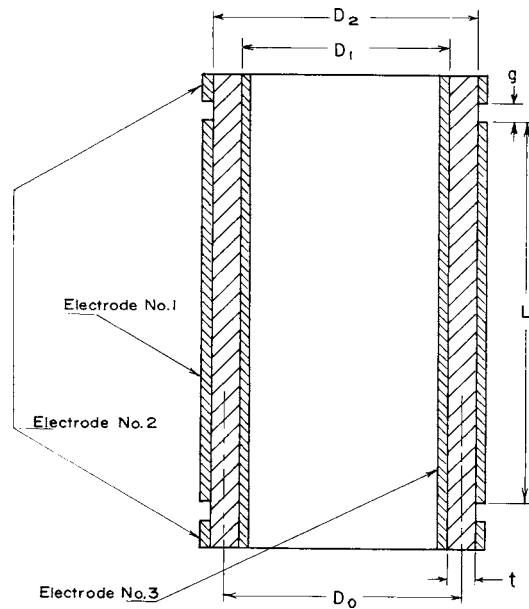

$D_0 = (D_1 + D_2)/2$ $L > 4t$ $g \ll L$ $2t$ Volume Resistivity $g \ll L$ $2t$ Surface Resistivity
FIG. 5 Tubular Specimen for Measuring Volume and Surface Resistances or Conductances

6.1.6 *Metal Foil*, Fig. 4, may be applied to specimen surfaces as electrodes. The usual thickness of metal foil used for resistance or conductance studies of dielectrics ranges from 6 to 80 μm . Lead or tin foil is in most common use, and is usually attached to the test specimen by a minimum quantity of petrolatum, silicone grease, oil, or other suitable material, as an adhesive. Such electrodes shall be applied under a smoothing pressure sufficient to eliminate all wrinkles, and to work excess adhesive toward the edge of the foil where it can be wiped off with a cleansing tissue. One very effective method is to use a hard narrow roller (10 to 15 mm wide), and to roll outward on the surface until no visible imprint can be made on the foil with the roller. This technique can be used satisfactorily only on specimens that have very flat surfaces. With care, the adhesive film can be reduced to 2.5 μm . As this film is in series with the specimen, it will always cause the measured resistance to be too high. This error may become excessive for the lower-resistivity specimens of thickness less than 250 μm . Also the hard roller can force sharp particles into or through thin films (50 μm). Foil electrodes are not porous and will not allow the test specimen to condition after the electrodes have been applied. The adhesive may lose its effectiveness at elevated temperatures necessitating the use of flat metal back-up plates under pressure. It is possible, with the aid of a suitable cutting device, to cut a proper width strip from one electrode to form a guarded and guard electrode. Such a three-terminal specimen normally cannot be used for surface resistance or conductance measurements because of the grease remaining on the gap surface. It may be very difficult to clean the entire gap surface without disturbing the adjacent edges of the electrode.

6.1.7 *Colloidal Graphite*, Fig. 4, dispersed in water or other suitable vehicle, may be brushed on nonporous, sheet insulating materials to form an air-drying electrode. Masking tapes or clamp-on masks may be used (6.1.4). This electrode material is recommended only if all of the following conditions are met:

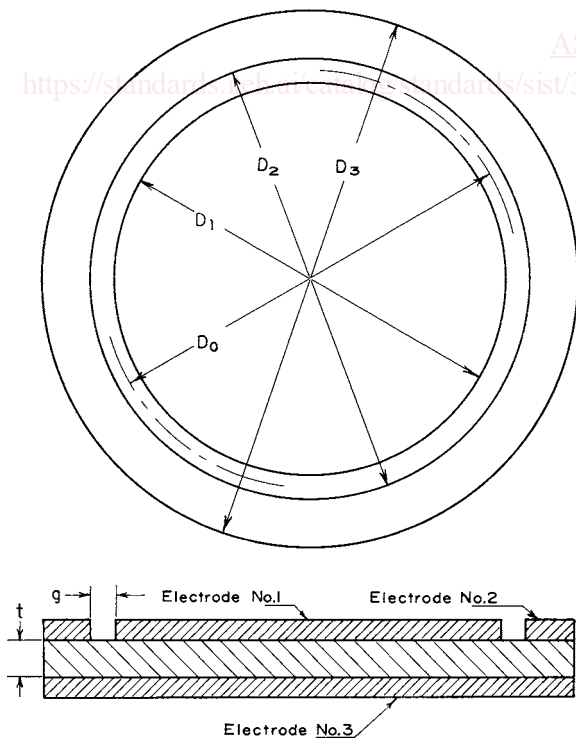

Volume Resistivity $g \ll L$ $2t$ Surface Resistivity
FIG. 4 Flat Specimen for Measuring Volume and Surface Resistances or Conductances

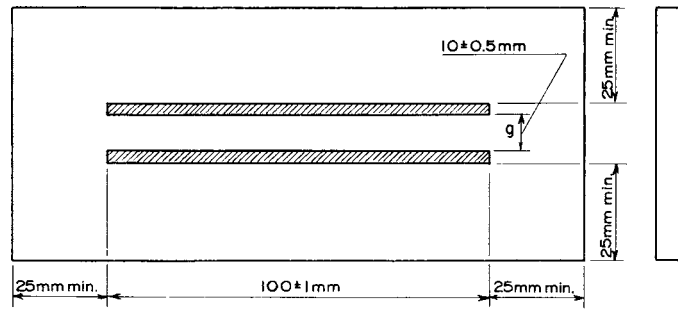

A - Plate Specimen

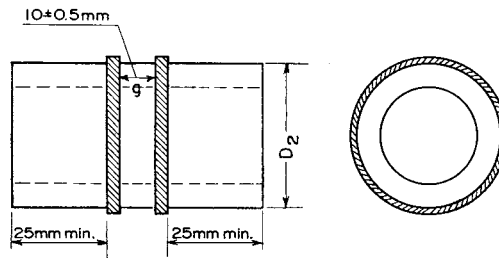

B - Tube or Rod Specimen

FIG. 6 Conducting-Paint Electrodes

6.1.7.1 The material to be tested must accept a graphite coating that will not flake before testing.

6.1.7.2 The material being tested must not absorb water readily, and

6.1.7.3 Conditioning must be in a dry atmosphere (Procedure B, Methods D 618), and measurements made in this same atmosphere.

6.1.8 Mercury or other liquid metal electrodes give satisfactory results. Mercury is not recommended for continuous use or at elevated temperatures due to toxic effects. **(Warning—**Mercury metal vapor poisoning has long been recognized as a hazard in industry. The maximum exposure limits are set by the American Conference of Governmental Industrial Hygienists.⁸ The concentration of mercury vapor over spills from broken thermometers, barometers, or other instruments using mercury can easily exceed these exposure limits. Mercury, being a liquid and quite heavy, will disintegrate into small droplets and seep into cracks and crevices in the floor. The use of a commercially available emergency spill kit is recommended whenever a spill occurs. The increased area of exposure adds significantly to the mercury vapor concentration in air. Mercury vapor concentration is easily monitored using commercially available sniffers. Spot checks should be made periodically around operations where mercury is exposed to the atmosphere. Thorough checks should be made after spills.) The metal forming the upper electrodes should be confined by stainless steel rings, each of which should have its lower rim reduced to a sharp edge by beveling on the side away from the liquid metal. Fig. 7A and Fig. 7B show two electrode arrangements.

⁸ American Conference of Governmental and Industrial Hygienists, 6500 Glenway Ave., Building D-7, Cincinnati, OH, 45211.

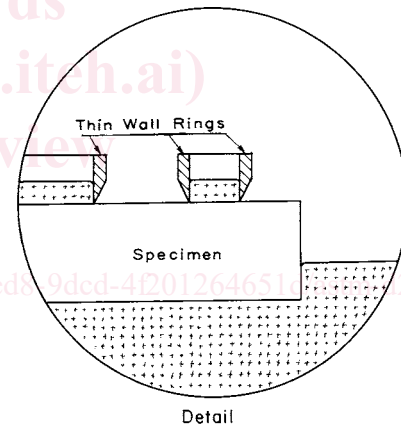

Detail

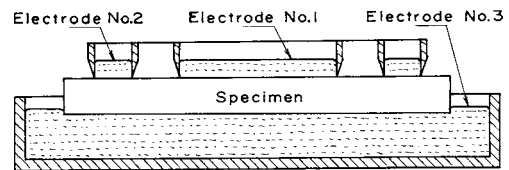

NOTE 1—Warning: See 6.1.8

FIG. 7 Mercury Electrodes for Flat, Solid Specimens

6.1.9 Flat Metal Plates, Fig. 4, (preferably guarded) may be used for testing flexible and compressible materials, both at room temperature and at elevated temperatures. They may be circular or rectangular (for tapes). To ensure intimate contact with the specimen, considerable pressure is usually required. Pressures of 140 to 700 kPa have been found satisfactory (see material specifications).

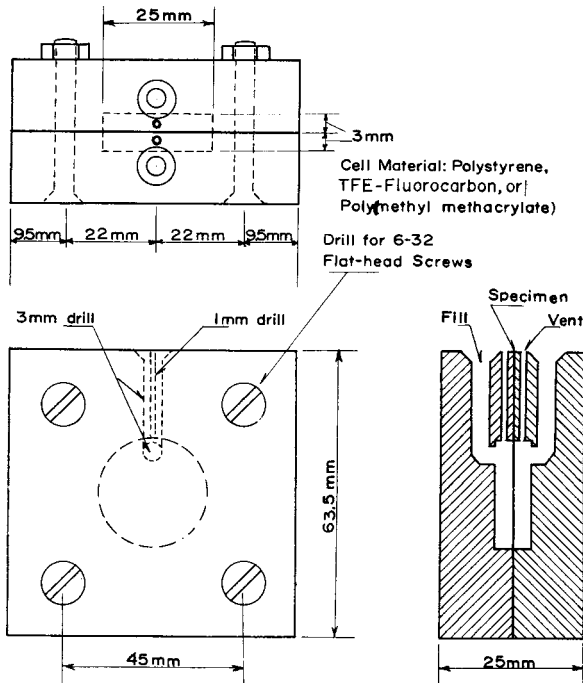

NOTE 1—Warning: See 6.1.8
FIG. 7 Mercury Cell for Thin Sheet Material (continued)

6.1.9.1 A variation of flat metal plate electrode systems is found in certain cell designs used to measure greases or filling compounds. Such cells are preassembled and the material to be

tested is either added to the cell between fixed electrodes or the electrodes are forced into the material to a predetermined electrode spacing. Because the configuration of the electrodes in these cells is such that the effective electrode area and the distance between them is difficult to measure, each cell constant, K , (equivalent to the A/t factor from Table 1) can be derived from the following equation:

$$K = 3.6 \pi C = 11.3 C \quad (1)$$

where:

K has units of centimetres, and

C has units of picofarads and is the capacitance of the electrode system with air as the dielectric. See Test Methods D 150 for methods of measurement for C .

6.1.10 *Conducting Rubber* has been used as electrode material, as in Fig. 4, and has the advantage that it can quickly and easily be applied and removed from the specimen. As the electrodes are applied only during the time of measurement, they do not interfere with the conditioning of the specimen. The conductive-rubber material must be backed by proper plates and be soft enough so that effective contact with the specimen is obtained when a reasonable pressure is applied.

NOTE 1—There is evidence that values of conductivity obtained using conductive-rubber electrodes are always smaller (20 to 70 %) than values obtained with tinfoil electrodes (6). When only order-of-magnitude accuracies are required, and these contact errors can be neglected, a properly designed set of conductive-rubber electrodes can provide a rapid means for making conductivity and resistivity determinations.

6.1.11 *Water* is widely employed as one electrode in testing insulation on wires and cables. Both ends of the specimen must be out of the water and of such length that leakage along the

TABLE 1 Calculation of Resistivity or Conductivity^A

Type of Electrodes or Specimen	Volume Resistivity, $\Omega\text{-cm}$	Volume Conductivity, S/cm
	$\rho_v = \frac{A}{t} R_v$	$\gamma_v = \frac{t}{A} G_v$
Circular (Fig. 4)	$A = \frac{\pi(D_1 + g)^2}{4}$	
Rectangular	$A = (a + g)(b + g)$	
Square	$A = (a + g)^2$	
Tubes (Fig. 5)	$A = \pi D_o(L + g)$	
Cables	$\rho_v = \frac{2\pi L R_v}{\ln \frac{D_2}{D_1}}$	$\gamma_v = \frac{\ln \frac{D_2}{D_1}}{2\pi L R_v}$
	Surface Resistivity, Ω (per square)	Surface Conductivity, S (per square)
	$\rho_s = \frac{P}{g} R_s$	$\gamma_s = \frac{g}{P} G_s$
Circular (Fig. 4)	$P = \pi D_o$	
Rectangular	$P = 2(a + b + 2g)$	
Square	$P = 4(a + g)$	
Tubes (Figs. 5 and 6)	$P = 2\pi D_2$	

Nomenclature:

A = the effective area of the measuring electrode for the particular arrangement employed,
 P = the effective perimeter of the guarded electrode for the particular arrangement employed,
 R_v = measured volume resistance in ohms,
 G_v = measured volume conductance in siemens,
 R_s = measured surface resistance in ohms,
 G_s = measured surface conductance in siemens,
 t = average thickness of the specimen,
 D_o, D_1, D_2, g, L = dimensions indicated in Figs. 4 and 6 (see Appendix X2 for correction to g),
 a, b = lengths of the sides of rectangular electrodes, and
 \ln = natural logarithm.

^AAll dimensions are in centimetres.