



Designation: F 482 – 03

## Standard Test Method for Corrosion of Aircraft Metals by Total Immersion in Maintenance Chemicals<sup>1</sup>

This standard is issued under the fixed designation F 482; the number immediately following the designation indicates the year of original adoption or, in the case of revision, the year of last revision. A number in parentheses indicates the year of last reapproval. A superscript epsilon ( $\epsilon$ ) indicates an editorial change since the last revision or reapproval.

### 1. Scope

1.1 This test method covers the determination of the corrosiveness of tank-type aircraft maintenance chemicals on aircraft metals and the corrodibility of metals in these maintenance chemicals with time. The determination is made under conditions of total immersion by a combination of weight change measurements and visual qualitative determinations of change.

1.2 The values stated in SI units are to be regarded as the standard. The values given in parentheses are for information only.

1.3 *This standard does not purport to address all of the safety concerns, if any, associated with its use. It is the responsibility of the user of this standard to establish appropriate safety and health practices and determine the applicability of regulatory limitations prior to use.* For specific precautions, see Section 5.

### 2. Referenced Documents

#### 2.1 ASTM Standards:

- D 235 Specification for Mineral Spirits (Petroleum Spirits) (Hydrocarbon Dry Cleaning Solvent)<sup>2</sup>
- D 329 Specification for Acetone<sup>2</sup>
- D 740 Specification for Methyl Ethyl Ketone<sup>2</sup>
- D 1193 Specification for Reagent Water<sup>3</sup>
- E 1 Specification for ASTM Thermometers<sup>4</sup>

### 3. Significance and Use

3.1 This test method not only provides information on the accumulated effects of corrosion at specific time periods under a given set of conditions, but also provides information on the initial rate of corrosion of virgin metal, the corrosion rate of metal per unit time after long exposure, and the initial

<sup>1</sup> This test method is under the jurisdiction of ASTM Committee F07 on Aerospace and Aircraft and is the direct responsibility of Subcommittee F07.07 on Qualification Testing of Aircraft Cleaning Materials.

Current edition approved Apr. 10, 2003. Published May 2003. Originally published in 1977. Last previous edition approved in 1999 as F 482 – 84 (1999) <sup>$\epsilon$ 1</sup>.

<sup>2</sup> Annual Book of ASTM Standards, Vol 06.04.

<sup>3</sup> Annual Book of ASTM Standards, Vol 11.01.

<sup>4</sup> Annual Book of ASTM Standards, Vol 14.03.

corrosion rate of virgin metal after long exposure of the corroding fluid to metal. The test also provides a means of determining the direction corrosion will take with time, although causes for increase or decrease in the corrosiveness and corrodibility of media and metal (such as passive film formation or destruction, depletion of corrosive contaminate, and so forth) as a function of time are not given.

### 4. Apparatus

4.1 *Wide-Mouth Glass Jar or Flask* of suitable sizes (3000 to 4000 mL), capable of accommodating a reflux condenser, a thermometer, and a specimen support system. Fig. 1 shows a typical arrangement, but any array meeting the provisions of 4.2-4.5 is acceptable.

4.1.1 If agitation is required, use an apparatus capable of accepting a stirring mechanism, such as a magnetic stirrer or impeller. Choose the glass jar or flask such that the specimens will remain fully immersed in a vertical position during the test, and the ratio of area of immersed metal to volume of solution will be in accordance with 8.1.

4.2 *Specimen-Supporting Device*—a glass or fluorocarbon plastic supporting system designed to keep the specimen fully immersed while assuring free contact with the corroding solution, and designed to physically isolate the specimens from each other.

4.3 *Condenser*—a glass reflux condenser of the water-cooled type, having a condenser jacket 200 to 300 mm in length.

4.4 *Constant-Temperature Device*—Use any suitable regulated heating device (mantle, hot plate, or bath) to maintain the solution at the required temperature.

4.5 *Thermometer*—an ASTM 75-mm (3-in.) immersion thermometer having a range from  $-18$  to  $150^{\circ}\text{C}$  ( $0$  to  $302^{\circ}\text{F}$ ) and conforming to requirements for Thermometer 1F in accordance with Specification E 1.

### 5. Safety Precautions

5.1 The solvents used in the cleaning of test specimens are flammable and harmful if inhaled. Keep away from sparks and open flames. Avoid breathing vapors and prolonged or repeated contact with the skin. Use with adequate ventilation.

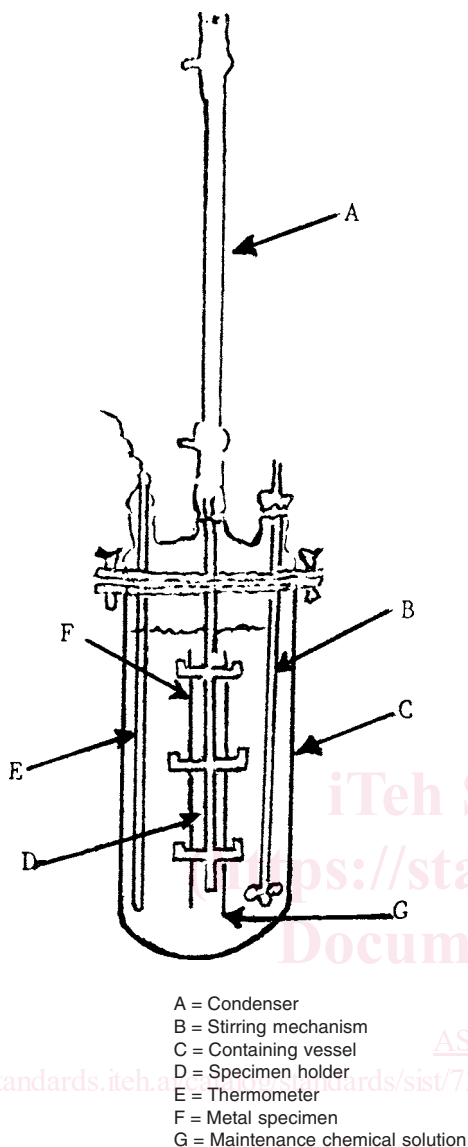

NOTE—THIS IS ONE FORM THAT THE EQUIPMENT CAN TAKE, AND IS NOT MANDATORY. ANY ARRAY MEETING THE REQUIREMENTS OF 4.2-4.5 IS ACCEPTABLE.

FIG. 1 Test Apparatus

5.2 Flammable solvents, acids, or alkalis, or other toxic compounds are occasionally found in the material used for aircraft maintenance. Take suitable precautions to prevent personnel injury.

## 6. Test Specimens

6.1 The test specimens of a given alloy shall be taken from the same sheet stock and shall measure 50.8 by 25.4 by 1.6 mm (2 by 1 by 0.06 in.) with a 3.2-mm (0.125-in.) diameter mounting hole suitably located at one end of the specimen. Test at least two and preferably three replicates in each concentration of maintenance chemical solution in accordance with 8.2. The total area of the specimen shall be taken as 28.2 cm<sup>2</sup> (4.4 in.<sup>2</sup>).

## 7. Test Specimen

7.1 Preheat the test specimens to 60 ± 2°C (150 ± 5°F) and immerse in a beaker containing Mineral Spirits, Type II, conforming to Specification D 235. Swab the surface of the individual specimen thoroughly using clean forceps to hold the specimen and the cotton swab.

7.2 Shake off the excess solvent. Transfer and immerse the test specimens separately several times in a beaker of methyl ethyl ketone conforming to Specification D 740.

7.3 Shake off excess methyl ethyl ketone and dry in a vacuum desiccator or in a low temperature oven at 37.7 ± 3°C (100 ± 5°F) for 15 min.

## 8. Conditioning

8.1 *Volume of Solution*—The volume of solution shall be 500 mL per specimen. Use fresh solution for each set of replicates.

8.2 *Solution Concentration*:

8.2.1 Unless otherwise specified, test the specimens in solutions of the maintenance chemical in the concentrated as-received condition and at the recommended dilution using distilled or deionized water conforming to Specification D 1193, Type IV. (For solid materials, concentrated condition shall mean in a saturated solution of the solid material.) In case the material is not soluble to the extent noted, record this fact and continue with the test.

8.2.2 Test diphasic materials with an appropriate amount of each phase loaded into the test vessel to simulate use conditions. Totally immerse the corrosion specimens in the working phase of the maintenance chemical.

8.2.3 If water is not used as the diluent, record the type and specification of diluent used in the test.

8.3 *Temperature*—Unless otherwise specified, the temperature shall be 37.7 ± 3°C (100 ± 2°F).

8.4 *Test Duration*—Total test duration shall be 168 h, with specimens being added or removed at intermediate intervals.

8.5 If the maintenance chemical is to be used with agitation, also test the specimens with appropriate agitation to simulate use conditions.

## 9. Procedure

9.1 Weigh four of five specimens ( $S_1$ ,  $S_2$ ,  $S_3$ , and  $S_4$ ) of the same alloy to the nearest 0.1 mg. Record the weights  $S_1W_1$ ,  $S_2W_1$ ,  $S_3W_1$ ,  $S_4W_1$ . Retain the fifth specimen of each alloy for comparison purposes.

9.2 Immerse three of the specimens ( $S_1$ ,  $S_2$ , and  $S_3$ ) in the test solution using only specimens of the same alloy in the containing vessel. Retain  $S_4$  for use in accordance with 9.5.

9.3 At the end of 48-h exposure time, remove  $S_1$  and proceed as follows:

9.3.1 Rinse thoroughly under hot tap water, 49 to 60°C (120 to 140°F), while scrubbing with a stiff bristle brush. Follow with distilled or deionized water conforming to Specification D 1193, Type IV at room temperature.

9.3.2 Rinse with a stream of acetone conforming to Specification D 329 from a wash bottle and dry.