



Designation: B 832 – 93 (Reapproved 2003)

## Standard Guide for Electroforming with Nickel and Copper<sup>1</sup>

This standard is issued under the fixed designation B 832; the number immediately following the designation indicates the year of original adoption or, in the case of revision, the year of last revision. A number in parentheses indicates the year of last approval. A superscript epsilon ( $\epsilon$ ) indicates an editorial change since the last revision or reapproval.

### 1. Scope

1.1 This guide covers electroforming practice and describes the processing of mandrels, the design of electroformed articles, and the use of copper and nickel electroplating solutions for electroforming.

1.2 *This standard does not purport to address all of the safety concerns, if any, associated with its use. It is the responsibility of the user of this standard to establish appropriate safety and health practices and determine the applicability of regulatory limitations prior to use.*

### 2. Referenced Documents

#### 2.1 ASTM Standards:

- B 183 Practice for Preparation of Low-Carbon Steel for Electroplating<sup>2</sup>
- B 242 Practice for Preparation of High-Carbon Steel for Electroplating<sup>2</sup>
- B 252 Practice for Preparation of Zinc Alloy Die Castings for Electroplating and Conversion Coatings<sup>2</sup>
- B 253 Guide for Preparation of Aluminum Alloys for Electroplating<sup>2</sup>
- B 254 Practice for Preparation of and Electroplating on Stainless Steel<sup>2</sup>
- B 281 Practice for Preparation of Copper and Copper-Base Alloys for Electroplating and Conversion Coatings<sup>2</sup>
- B 311 Test Method for Density Determination for Powder Metallurgy (P/M) Materials Containing Less Than Two Percent Porosity<sup>2</sup>
- B 343 Practice for Preparation of Nickel for Electroplating with Nickel<sup>2</sup>
- B 374 Terminology Relating to Electroplating<sup>2</sup>
- B 489 Practice for Bend Test for Ductility of Electrodeposited and Autocatalytically Deposited Metal Coatings on Metals<sup>2</sup>
- B 490 Practice for Micrometer Bend Test for Ductility of Electrodeposits<sup>2</sup>

- B 558 Practice for Preparation of Nickel Alloys for Electroplating<sup>2</sup>
- B 571 Practice for Qualitative Adhesion Testing of Metallic Coatings<sup>2</sup>
- B 578 Test Method for Microhardness of Electroplated Coatings<sup>2</sup>
- B 636 Test Method for Measurement of Internal Stress of Plated Metallic Coatings with the Spiral Contractometer<sup>2</sup>
- B 659 Guide for Measuring Thickness of Metallic and Inorganic Coatings<sup>2</sup>
- B 849 Specification for Pre-Treatments of Iron or Steel for Reducing Risk of Hydrogen Embrittlement<sup>2</sup>
- E 8 Test Methods of Tension Testing of Metallic Materials<sup>3</sup>
- E 384 Test Method for Microhardness of Materials<sup>3</sup>

### 3. Summary of Electroforming Practice

3.1 Electroforming is defined (see Terminology B 374) as the production or reproduction of articles by electrodeposition upon a mandrel or mold that is subsequently separated from the deposit.

3.2 The basic fabrication steps are as follows: a suitable mandrel is fabricated and prepared for electroplating; the mandrel is placed in an appropriate electroplating solution and metal is deposited upon the mandrel by electrolysis; when the required thickness of metal has been applied, the metal-covered mandrel is removed from the solution; and the mandrel is separated from the electrodeposited metal. The electroform is a separate, free-standing entity composed entirely of electrodeposited metal. Electroforming is concerned with the fabrication of articles of various kinds.

### 4. Significance and Use

4.1 The specialized use of the electroplating process for electroforming results in the manufacture of tools and products that are unique and often impossible to make economically by traditional methods of fabrication. Current applications of nickel electroforming include: textile printing screens; components of rocket thrust chambers, nozzles, and motor cases; molds and dies for making automotive arm-rests and instrument panels; stampers for making phonograph records, video-discs, and audio compact discs; mesh products for making

<sup>1</sup> This guide is under the jurisdiction of ASTM Committee B08 on Metallic and Inorganic Coatings and is the direct responsibility of Subcommittee B08.08.01 on Engineering Coatings.

Current edition approved Feb. 10, 2003. Published May 2003. Originally approved in 1993. Last previous edition approved in 1998 as B 832 – 93 (1998).

<sup>2</sup> *Annual Book of ASTM Standards*, Vol 02.05.

<sup>3</sup> *Annual Book of ASTM Standards*, Vol 03.01.

porous battery electrodes, filters, and razor screens; and optical parts, bellows, and radar wave guides (1-3).<sup>4</sup>

4.2 Copper is extensively used for electroforming thin foil for the printed circuit industry. Copper foil is formed continuously by electrodeposition onto rotating drums. Copper is often used as a backing material for electroformed nickel shells and in other applications where its high thermal and electrical conductivities are required. Other metals including gold are electroformed on a smaller scale.

4.3 Electroforming is used whenever the difficulty and cost of producing the object by mechanical means is unusually high; unusual mechanical and physical properties are required in the finished piece; extremely close dimensional tolerances must be held on internal dimensions and on surfaces of irregular contour; very fine reproduction of detail and complex combinations of surface finish are required; and the part cannot be made by other available methods.

## 5. Processing of Mandrels for Electroforming

### 5.1 General Considerations:

5.1.1 Mandrels may be classified as conductors or nonconductors of electricity, and each of these may be permanent, semipermanent, or expendable (Table 1).

**TABLE 1 Types of Mandrel Materials**

| Types                         | Typical Materials   |
|-------------------------------|---|
| Conductors                    |   |
| Expendable                    | Low-melting point alloys; for example, bismuth-free 92 % tin and 8 % zinc<br>Aluminum alloys  |
| Permanent                     | Zinc alloys<br>Nickel<br>Austenitic Stainless<br>Invar, Kovar<br>Copper and brass<br>Nickel-plated steel<br>Nickel/chromium-plated aluminum |
| Nonconductors                 |   |
| Expendable                    | Wax<br>Glass  |
| Permanent (or Semi-Permanent) | Rigid and collapsible plastic; for example, epoxy resins and polyvinyl chloride<br>Wood   |

5.1.2 Whether or not a mandrel is a conductor will determine the procedures required to prepare it for electroforming. Conductive mandrels are usually pure metals or alloys of metals and are prepared by standard procedures but may require an additional thin parting film to facilitate separation of the electroform from the mandrel (unless the mandrel is removed by melting or chemical dissolution).

5.1.3 Whether or not a permanent or expendable mandrel should be used is largely dependent on the particular article that is to be electroformed. If no reentrant shapes or angles are involved, it is possible to use permanent, rigid mandrels that

can be separated from the finished electroform mechanically and reused. If reentrant angles and shapes are involved, it is necessary to use mandrel materials that can be removed by melting or by chemical dissolution, or materials that are collapsible, such as polyvinyl chloride and other plastics. In some cases, multiple piece mandrels are used that can be removed even with reentrant features.

5.1.4 Many solid materials can be used to fabricate mandrels for electroforming, but the following generalizations may help in selecting a suitable material: permanent mandrels are preferred for accuracy and for large production runs; expendable mandrels must be used whenever the part is so designed that a permanent mandrel cannot be withdrawn; and it is important that the mandrel retain its dimensional stability in warm plating baths. Wax and most plastics expand when exposed to electroplating solutions operated at elevated temperatures. In such cases, it may be necessary to use acid copper, nickel sulfamate, and other electroplating solutions that function at room temperature.

### 5.2 Mandrel Design:

5.2.1 The electroforming operation can often be simplified by design changes that do not impair the functioning of the piece. Some of the design considerations are summarized in 5.2.2, 5.2.3, 5.2.4, 5.2.5, and 5.2.6. Examples of mandrel shapes that may present problems during electroforming are illustrated in Fig. 1.

5.2.2 Exterior (convex) angles should be provided with as generous a radius as possible to avoid excessive build up and treeing of the deposit during electroforming. Interior (concave) angles on the mandrel should be provided with a fillet radius of at least 0.05 cm per 5 cm (0.02 in. per 2 in.) of length of a side of the angle.

5.2.3 Whenever possible, permanent mandrels should be tapered at least 0.08 mm per m (0.001 in. per ft) to facilitate removal from the mandrel. (Where this is not permissible, the mandrel may be made of a material with a high or low coefficient of thermal expansion so that separation can be effected by heating or cooling).

5.2.4 A fine surface finish on the mandrel, achieved by lapping or by electropolishing, will generally facilitate separation of mandrel and electroform. A finish of 0.05  $\mu\text{m}$  (2  $\mu\text{in.}$ ) rms is frequently specified.

5.2.5 Flat bottom grooves, sharp angle indentations, blind holes, fins, v-shaped projections, v-bottom grooves, deep scoops, slots, concave recesses, and rings and ribs can cause problems with metal distribution during electroforming unless inside and outside angles and corners are rounded.

5.2.6 An engineering drawing of the mandrel, the electroformed article, and auxiliary equipment or fixture for separating the electroform from the mandrel should be prepared. The drawing of the mandrel should provide for electrical connections to be made in nonfunctional areas of the electroform. It should provide reference points for and mechanical means of holding if finish machining is necessary before removal of the mandrel.

### 5.3 Mandrel Fabrication:

5.3.1 The method of fabrication of the mandrel will depend on the type selected, the material chosen, and the object to be

<sup>4</sup> The boldface numbers in parentheses refer to the list of references at the end of this standard.

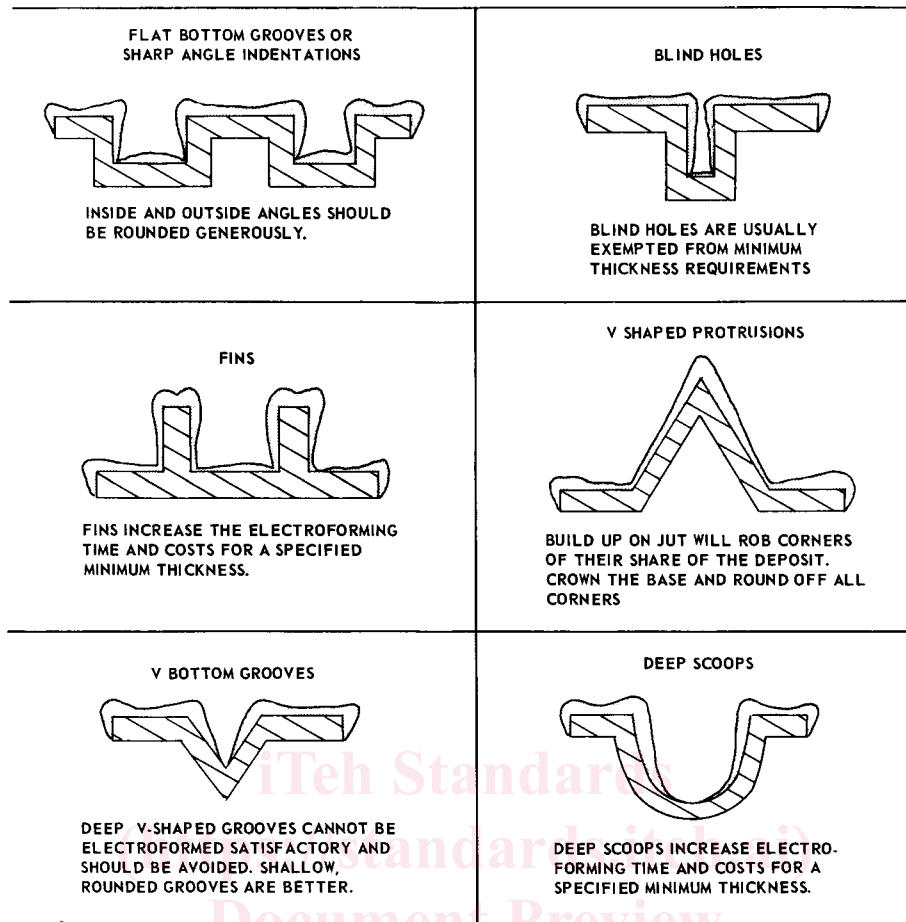

NOTE—Examples of deposit distribution on contours that require special consideration are shown in an exaggerated fashion. The designer should confer with the electroformer before designing an electroform having any of these contours. An experienced electroformer can minimize some of the exaggeration shown.

FIG. 1 Examples of Deposit Distribution on Electroforms

electroformed. Mandrels may be manufactured by casting, machining, electroforming, and other techniques. Permanent mandrels can be made by any of the conventional pattern-making processes.

#### 5.4 Preparing Non-Conducting Mandrels:

5.4.1 Nonconducting mandrels must be made impervious to water and other processing solutions and then rendered conductive. Porous materials, for example, leather and plastic, may be impregnated with wax, shellac, lacquer, or a synthetic resin formulation. It is often preferable to use thin films of lacquer to seal porous, nonmetallic mandrels.

5.4.2 Nonconducting materials may be rendered conductive by applying a chemically reduced film of silver, copper, or nickel to the surface. In general, these processes are carried out by spraying the reagent containing the metal ions of choice simultaneously with a specific reducing agent onto the surface of the mandrel using a double-nozzle spray gun. The chemicals react at the surface; the metal is reduced and is deposited on the mandrel surface. Chemical reduction processes are preferred because dimensional accuracy is not affected, the film has little adhesion, and parting is not difficult. If necessary, a silver film can be stripped from a nickel electroform with either nitric acid, warm sulfuric acid, or a cyanide solution.

5.4.3 Other ways of making non-conducting materials conductive include: using finely divided metal powders dispersed in binders (“bronzing”), applying finely divided graphite to wax, and to natural or synthetic rubbers that have an affinity for graphite, and applying graphite with a binder.

5.4.4 Vapor deposition of silver and other metals is preferred for nonconducting mandrels used in the semiconductor industry, the optical disc industry, and the manufacture of holograms. In these cases the mandrel must be made of a material that does not outgas in the vacuum chamber. Glass is the preferred substrate for making masters and stampers for optical read-out discs of all kinds.

#### 5.5 Preparing Metallic Mandrels:

5.5.1 Standard procedures should be used whenever adherent electrodeposits are applied to metallic mandrels prior to and in preparation for electroforming. See Practices B 183, B 242, B 254, B 281, and B 558, for example.

5.5.2 With most metallic mandrels an additional chemical treatment that forms a parting film on the surface is required to separate the electroform from the mandrel. After removing all traces of grease and oil by means of solvents, various metallic mandrels are given different treatments for this purpose (see 5.5.3, 5.5.4, 5.5.5, 5.5.6, and 5.5.7).

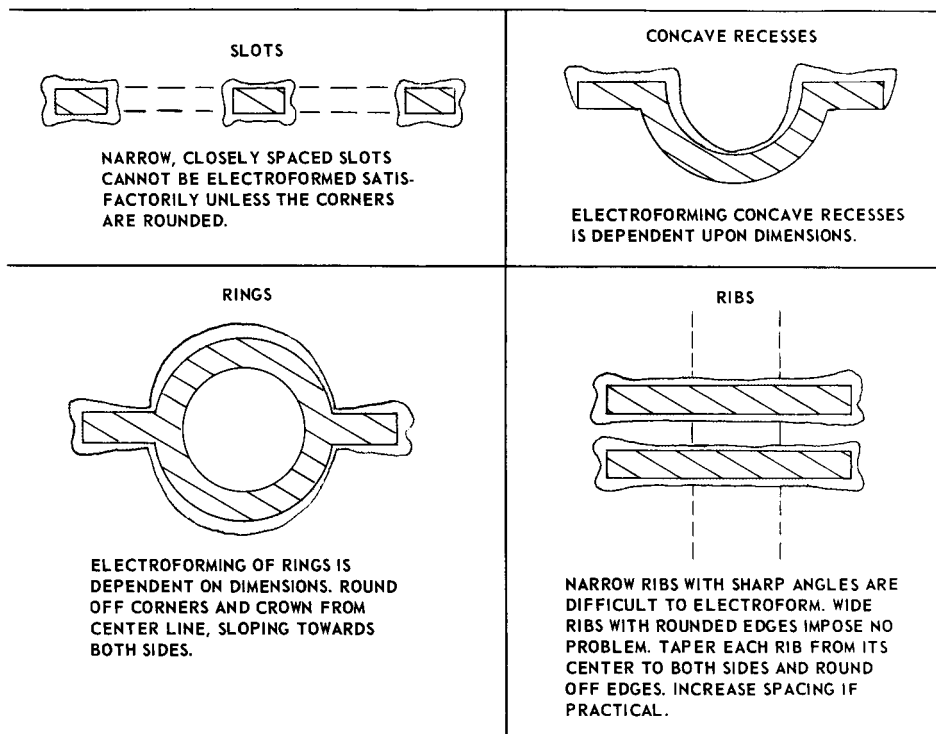

FIG. 1 (continued)

5.5.3 Stainless steel, nickel, and nickel- or chromium-plated steel are cleaned using standard procedures, rinsed, and passivated by immersion in a 2 % solution of sodium dichromate for 30 to 60 s at room temperature. The mandrel must then be rinsed to remove all traces of the dichromate solution.

5.5.4 Copper and brass mandrels that have been nickel and/or chromium-plated may be treated as described in 5.5.3. If not electroplated, the surface can be made passive by immersion in a solution containing 8 g/L sodium sulfide.

5.5.5 Aluminum alloys may require special treatments even when they are used as expendable mandrels to be separated by chemical dissolution. If the deposits are highly stressed, it may be necessary to use the zincate or stannate treatments included in Guide B 253 to achieve a degree of adhesion that will prevent lifting of the deposit from the mandrel. When low-stressed deposits (near zero) are being produced, treatment of the aluminum by degreasing, cathodic alkaline cleaning, and immersion in a 50 % solution of nitric acid may be sufficient.

5.5.6 Zinc and its alloys may require no other preparation than conventional cleaning if used for expendable mandrels and are to be parted by chemical dissolution. In the case of nickel electroforming, it is necessary to electroplate the zinc alloy with copper and treat it accordingly to prevent attack of the mandrel. See Practice B 252.

5.5.7 The low-melting point alloys included in Table 1 employed to make expendable mandrels that can be melted away have a tendency to leave a residue of tin on the surface of the electroform. The mandrel can be plated with copper prior to electroforming to prevent this.

## 6. Nickel and Copper Electroforming Solutions

6.1 The choice of metal selected for the electroform will depend on the mechanical and physical properties required in

the finished article as related to function. The two metals selected most frequently are nickel and copper. The operation and control of nickel and copper electroforming solutions are described in this section.

6.2 The nickel electroplating solutions commonly used for electroforming are Watts and nickel sulfamate with and without addition agents. The advantages of nickel electroforming from sulfamate solutions are the low internal stress of the deposits and the high rates of deposition that are possible. The important copper electroforming solutions are copper sulfate and copper fluoborate. The formulations of nickel electroforming solutions, typical operating conditions, and typical mechanical properties of the deposits are given in Table 2. Similar information for copper electroforming is given in Table 3.

6.3 *Watts Solutions*—The Watts bath contains nickel sulfate, nickel chloride, and boric acid and yields nickel deposits that are matte in appearance and that are tensively stressed. The solution is relatively inexpensive and is successfully used for electroforming. Nickel sulfate is the main source of nickel ions. Nickel chloride increases solution conductivity and has a beneficial effect on the uniformity of metal distribution at the cathode. Boric acid acts as a buffer to control pH at the cathode-solution interface. Antipitting agents (wetting agents) are essential for avoiding pitting due to the clinging of air and hydrogen bubbles. With care, the internal stress of the electroformed nickel can be controlled by means of organic addition agents. See 8.3.

6.4 *Nickel Sulfamate Solutions*—A formulation for nickel sulfamate solutions is included in Table 2. These are analogous to Watts solutions in which the nickel sulfate is replaced with nickel sulfamate. The internal stress is lower than in the Watts