

INTERNATIONAL
STANDARD

ISO
10914

First edition
1996-12-01

**Assembly tools for screws and nuts —
Sockets and wrenches for spline drive**

iTeh STANDARD PREVIEW

Outils de manœuvre pour vis et écrous — Douilles et clés pour entraînement cannelé

ISO 10914:1996

<https://standards.iteh.ai/catalog/standards/sist/6f4a6bb8-8701-4a44-8c1b-a039c81a2345/iso-10914-1996>



Reference number
ISO 10914:1996(E)

Foreword

ISO (the International Organization for Standardization) is a worldwide federation of national standards bodies (ISO member bodies). The work of preparing International Standards is normally carried out through ISO technical committees. Each member body interested in a subject for which a technical committee has been established has the right to be represented on that committee. International organizations, governmental and non-governmental, in liaison with ISO, also take part in the work. ISO collaborates closely with the International Electrotechnical Commission (IEC) on all matters of electrotechnical standardization.

Draft International Standards adopted by the technical committees are circulated to the member bodies for voting. Publication as an International Standard requires approval by at least 75 % of the member bodies casting a vote.

International Standard ISO 10914 was prepared by Technical Committee ISO/TC 29, *Small tools*, Subcommittee SC 10, *Assembly tools for screws and nuts, pliers and nippers*.

iTeh STANDARD PREVIEW
(standards.iteh.ai)

ISO 10914:1996
<https://standards.iteh.ai/catalog/standards/sist/6f4a6bb8-8701-4a44-8c1b-a039c81a2345/iso-10914-1996>

Assembly tools for screws and nuts — Sockets and wrenches for spline drive

1 Scope

This International Standard specifies the technical, dimensional and test requirements for hand-operated sockets and box wrenches used for the attachment and detachment of metric spline drive fasteners according to ISO 7403. It applies to tools listed in the classification of clause 3.

This type of tool is mainly used in the aeronautic industry. The overall dimensions are not in accordance with other International Standards relating to dimensions.

NOTE — The figures in this International Standard are descriptive, not restrictive, and are not intended to exclude any sockets and box wrenches provided they be in accordance with this International Standard.

ISO 10914:1996

<https://standards.iteh.ai/catalog/standards/sist/6f4a6bb8-8701-4a44-8c1b-a039c81a2345/iso-10914-1996>

2 Normative references

The following standards contain provisions which, through reference in this text, constitute provisions of this International Standard. At the time of publication, the editions indicated were valid. All standards are subject to revision, and parties to agreements based on this International Standard are encouraged to investigate the possibility of applying the most recent editions of the standards indicated below. Members of IEC and ISO maintain registers of currently valid International Standards.

ISO 1174-1:1996, *Assembly tools for bolts and screws — Driving squares — Part 1: Driving squares for hand socket tools.*

ISO 6508:1986, *Metallic materials — Hardness test — Rockwell Test (scales A-B-C-D-E-F-G-H-K).*

ISO 7403:1983, *Fasteners for aerospace construction — Spline drive wrenching configuration — Metric series.*

3 Classification

The following types and classes apply:

Type I: Sockets

- Class A: Regular
- Class B: Long
- Class C: Universal joint

Type II: Box wrench, double head, 15° offset

- Class D: Short length
- Class E: Regular length
- Class F: Long length

4 Dimensions

Female square dimensions shall conform to ISO 1174-1.

Spline drive size shall conform to ISO 7403. Socket dimensions shall conform to the dimensions given in tables 1, 2, 3 and 5. Wrench dimensions shall conform to those given in tables 7 and 8.

5 Technical requirements

5.1 Hardness

The sockets and wrenches shall have a hardness of 40 HRC to 54 HRC when tested in accordance with the conditions specified in ISO 6508.

5.2 Test mandrels

Mandrels shall be hardened to 55 HRC minimum and have smoothly finished wrench engagement surfaces. Mandrel engagement lengths shall conform to tables 4 and 6 for the sockets, and to table 7 for the wrenches. The spline mandrels shall conform to the minimum dimensions specified in ISO 7403 with tolerance h8.

5.3 Endurance test

ISO 10914:1996

<https://standards.iteh.ai/catalog/standards/sist/6f4a6bb8-8701-4a44-8c1b-1996122451610914-1996>

A socket or wrench, when tested, shall be capable of withstanding 2 000 applications of the torque cyclic fatigue load when engaged with a spline mandrel. Cyclic load shall be applied at a rate of 60 cycles per minute maximum. The sample tool shall be capable of withstanding the proof load following the cyclic load test.

6 Designation

A socket or universal joint for spline drive according to this International Standard shall be designated by

- a) "Socket";
- b) reference to this International Standard;
- c) nominal dimension of driving square, in millimetres;
- d) nominal size of spline drive, in millimetres;
- e) class.

EXAMPLES

Socket for spline drive of class B with a 6,3 mm driving square and nominal wrenching size of 10 mm is designated as follows:

Socket ISO 10914 - 6,3 × 10 - B

Universal joint (class C) for spline drive with a 12,5 mm driving square and nominal wrenching size of 18 mm is designated as follows:

Socket ISO 10914 - 12,5 × 18 - C

A box wrench, double head, 15° offset, for spline drive according to this International Standard shall be designated by

- “Box wrench”;
- reference to this International Standard;
- pairing of nominal spline drive sizes, in millimetres;
- class.

EXAMPLE

Box wrench, double head, for spline drive of class D, with a 7 mm × 8 mm pairing of nominal spline drive size is designated as follows:

Box wrench ISO 10914 - 7 × 8 - D

7 Marking

Sockets and wrenches shall be marked, permanently and legibly, with the following information:

- name or trademark of the manufacturer (or distributor);
- nominal size of spline drive.

iTeh STANDARD PREVIEW (standards.iteh.ai)

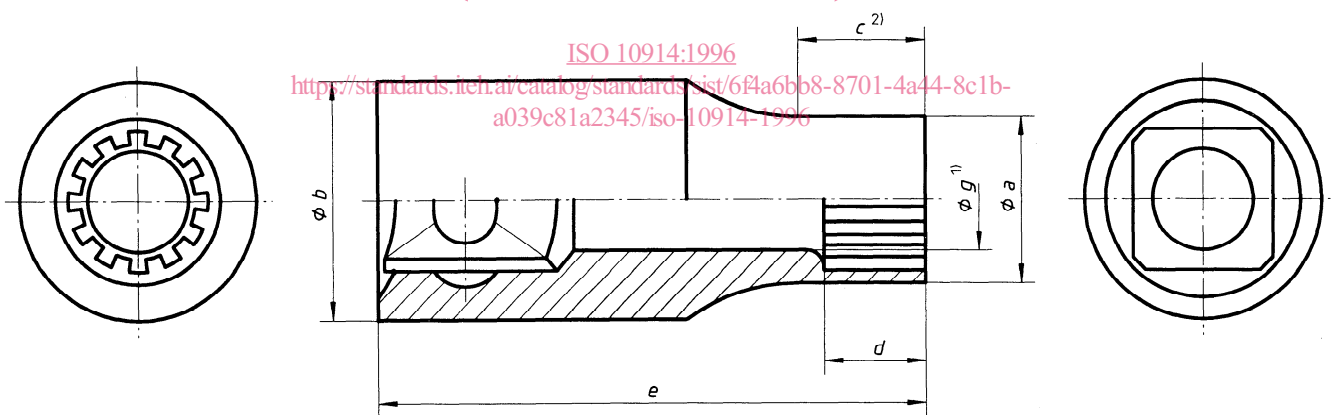

1) Bolt clearance diameter.

2) Length of cylinder of diameter a .

Figure 1 — Socket for spline drive

Table 1 — Socket dimensions, driving squares 6,3 mm and 10 mm

Dimensions in millimetres

Nominal spline drive size	Dimensions for all driving squares			Driving squares									
				6,3					10				
				Class A			Class B		Class A			Class B	
<i>a</i> max.	<i>d</i> min.	<i>g</i> min.	<i>b</i> max.	<i>c</i> min.	<i>e</i> max.	<i>c</i> min.	<i>e</i> max.	<i>b</i> max.	<i>c</i> min.	<i>e</i> max.	<i>c</i> min.	<i>e</i> max.	
5	7,8	4,8	4,5	11,2	5	26	25	50					
5,5	8,5	5,2	5	11,2	5,5	26	25,5	50					
6	9,1	5,6	5,5	11,2	6	26	26	50					
7	10,5	6,9	6,5	11,2	8	26	28	50					
8	11,8	8,4	7,5	11,8	—	26	—	50					
9	13,3	8,6	8,5	13,3	—	26	—	50	16,9	5	26	25	50
10	14,6	9,1	9,5	14,6	—	26	—	50	17	6	27,5	26	50
11	16,1	10,4	10,5						17,5	8	28,5	28	50
12	17,5	11,2	11,5						17,5	—	31	—	50
13	19,1	11,8	12,5						19,1	—	33,5	—	50
14	20,6	12,1	13,5						20,6	—	33,5	—	50

iTeh STANDARD PREVIEW
(standards.iteh.ai)

Table 2 — Socket dimensions, driving squares 12,5 mm and 20 mm

<https://standards.iteh.ai/catalog/standards/sist/6f4a6bb8-8701-4a44-8c1b-a039c81a2345/iso-10914-1996>

Dimensions in millimetres

Nominal spline drive size	Dimensions for all driving squares			Driving squares									
				12,5					20				
				Class A			Class B		Class A			Class B	
<i>a</i> max.	<i>d</i> min.	<i>g</i> min.	<i>b</i> max.	<i>c</i> min.	<i>e</i> max.	<i>c</i> min.	<i>e</i> max.	<i>b</i> max.	<i>c</i> min.	<i>e</i> max.	<i>c</i> min.	<i>e</i> max.	
12	17,5	11,2	11,5	22,2	8	33,5	52	81					
13	19,1	11,8	12,5	22,2	8	33,5	52	81					
14	20,6	12,1	13,5	22,2	8	33,5	52	81					
15	22,2	12,7	14,5	22,2	—	39,5	—	81					
16	23,2	13,6	15,5	23,2	—	39,5	—	81					
17	24,8	14	16,5	24,8	—	39,5	—	81					
18	26,2	14,7	17,5	26,2	—	39,5	—	81					
19	26,7	15,7	18,5	26,7	—	39,5	—	81	34,9	10	46	—	—
21	29,2	17	20,5	29,2	—	39,5	—	81	34,9	12	46,5	—	—
22	30,5	18	21,5	30,5	—	39,5	—	81	34,9	14	47,5	—	—
24	33	19,9	23,5						34,9	—	51	—	—
27	38,9	22,2	26,5						34,9	—	53	—	—

Table 3 — Socket dimensions, driving squares 25 mm and 40 mm

Dimensions in millimetres

Nominal spline drive size	Dimensions for all driving squares			Driving squares									
				25					40				
	a max.	d min.	g min.	Class A			Class B		Class A			Class B	
b max.				c min.	e max.	c min.	e max.	b max.	c min.	e max.	c min.	e max.	
27	38,9	22,2	26,5	51	12	65	—	—					
30	43,1	25,4	29,5	51	18	68,5	—	—					
32	45,9	26,9	31,5	51	20	74,5	—	—					
36	51,4	30,2	35,5	51,4	—	78	—	—	76,2	29	86,5	—	—
40	57	34,3	39,5	57	—	84	—	—	76,2	31	90	—	—
41	58,4	35	40,5						76,2	32	91	—	—
46	65,4	39,6	45,5						76,2	36	95,5	—	—
50	71	43,4	49,5						76,2	40	99,5	—	—

Table 4 — Socket torque requirements

Nominal spline drive size	Test mandrel engagement length	Driving squares													
		6,3		10		12		20		25		40			
		Torque requirements													
mm	mm	N·m													
		Cyclic load	Proof load	Cyclic load	Proof load	Cyclic load	Proof load	Cyclic load	Proof load	Cyclic load	Proof load	Cyclic load	Proof load	Cyclic load	Proof load
5	2,5	20	30												
5,5	2,8	25	35												
6	3	25	40												
7	3,5	35	55												
8	4	55	80												
9	4,5	55	80	95	140										
10	5	55	80	135	195										
11	5,5			170	250										
12	6			200	280	290	420								
13	6,5			200	280	380	550								
14	7			200	280	480	690								
15	7,5			200	280	530	750								
16	8			200	280	550	790								
17	8,5					550	790								
18	9					550	790								
19	9,5					550	790	700	1 000						
21	10,5					550	790	950	1 350						
22	11					550	790	1 100	1 580						
24	12							1 460	2 140						
27	13,5							1 550	2 260	2 050	3 050				
30	15									2 800	4 100				
32	16									3 300	4 850				
36	18									3 500	5 300	4 900	7 000		
40	20									3 500	5 300	6 700	9 600		
41	20,5											7 300	10 500		
46	23											10 400	14 900		
50	25											12 500	18 000		

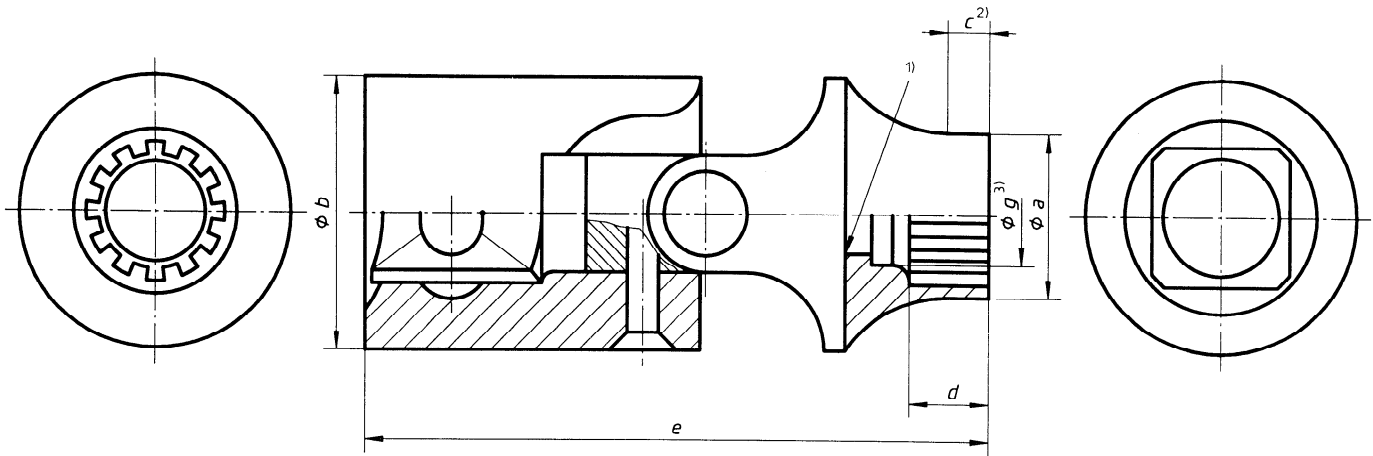

- 1) Optional through hole.
- 2) Length of cylinder of diameter a.
- 3) Bolt clearance diameter.

Figure 2 — Universal joint for spline drive

Table 5 — Universal joint dimensions

Dimensions in millimetres

Nominal spline drive size	Dimensions for all driving squares			Driving squares													
				(standards.iteh.ai)			6,3			10			12,5				
				a max.	d min.	g min.	b max.	c min.	e max.	b min.	c min.	e max.	b min.	c min.	e max.		
5	7,8	4,8	4,5	13,1	1	30											
5,5	8,5	5,2	5	13,1	1,5	32											
6	9,1	5,6	5,5	13,1	2	33,5											
7	10,5	6,9	6,5	13,1	3,5	34,5											
8	11,8	8,4	7,5	13,1	5	39,5											
9	13,3	8,6	8,5	13,1	—	41,5	19,1	2	51,5								
10	14,6	9,1	9,5	13,1	—	43	19,1	4	52,5								
11	16,1	10,4	10,5				19,1	5	53,5								
12	17,5	11,2	11,5				19,1	6	54,5	28,6	6	72,5					
13	19,1	11,8	12,5				19,1	—	55	28,6	7	72,5					
14	20,6	12	13,5				19,1	—	55,5	28,6	8	75					
15	22,2	12,7	14,5				19,1	—	56,5	28,6	9	76					
16	23,2	13,6	15,5				19,1	—	57	28,6	10	76					
17	24,8	14	16,5							28,6	11	78					
18	26,2	14,7	17,5							28,6	12	78					
19	26,7	15,7	18,5							28,6	13	80					
21	29,2	17	20,5							28,6	—	82					
22	30,5	18	21,5							28,6	—	83					
24	33	19,9	23,5							28,6	—	87					

Table 6 — Universal joint torque requirements

Nominal spline drive size mm	Test mandrel engagement length max. mm	Driving squares mm					
		6,3		10		12,5	
		Torque requirements N·m					
		Cyclic load	Proof load	Cyclic load	Proof load	Cyclic load	Proof load
5	2,5	20	30				
5,5	2,8	25	35				
6	3	25	40				
7	3,5	35	55				
8	4	40	60				
9	4,5	40	60	75	110		
10	5	40	60	75	110		
11	5,5			75	110		
12	6			75	110	135	200
13	6,5			75	110	135	200
14	7			75	110	135	200
15	7,5			75	110	135	200
16	8			75	110	135	200
17	8,5					135	200
18	9					135	200
19	9,5					135	200
21	10,5					135	200
22	11					135	200
24	12					135	200