

INTERNATIONAL
STANDARD

ISO
10914

First edition
1996-12-01

**Assembly tools for screws and nuts —
Sockets and wrenches for spline drive**

iTeh Standards

Outils de manœuvre pour vis et écrous — Douilles et clés pour entraînement cannelé

Document Preview

ISO 10914:1996

<https://standards.iteh.ai/catalog/standards/iso/6f4a6bb8-8701-4a44-8c1b-a039c81a2345/iso-10914-1996>



Reference number
ISO 10914:1996(E)

Foreword

ISO (the International Organization for Standardization) is a worldwide federation of national standards bodies (ISO member bodies). The work of preparing International Standards is normally carried out through ISO technical committees. Each member body interested in a subject for which a technical committee has been established has the right to be represented on that committee. International organizations, governmental and non-governmental, in liaison with ISO, also take part in the work. ISO collaborates closely with the International Electrotechnical Commission (IEC) on all matters of electrotechnical standardization.

Draft International Standards adopted by the technical committees are circulated to the member bodies for voting. Publication as an International Standard requires approval by at least 75 % of the member bodies casting a vote.

International Standard ISO 10914 was prepared by Technical Committee ISO/TC 29, *Small tools*, Subcommittee SC 10, *Assembly tools for screws and nuts, pliers and nippers*.

iTeh Standards
(<https://standards.itih.ai>)
Document Preview

[ISO 10914:1996](#)

<https://standards.itih.ai/catalog/standards/iso/6f4a6bb8-8701-4a44-8c1b-a039c81a2345/iso-10914-1996>

© ISO 1996

All rights reserved. Unless otherwise specified, no part of this publication may be reproduced or utilized in any form or by any means, electronic or mechanical, including photocopying and microfilm, without permission in writing from the publisher.

International Organization for Standardization
Case Postale 56 • CH-1211 Genève 20 • Switzerland

Printed in Switzerland

Assembly tools for screws and nuts — Sockets and wrenches for spline drive

1 Scope

This International Standard specifies the technical, dimensional and test requirements for hand-operated sockets and box wrenches used for the attachment and detachment of metric spline drive fasteners according to ISO 7403. It applies to tools listed in the classification of clause 3.

This type of tool is mainly used in the aeronautic industry. The overall dimensions are not in accordance with other International Standards relating to dimensions.

NOTE — The figures in this International Standard are descriptive, not restrictive, and are not intended to exclude any sockets and box wrenches provided they be in accordance with this International Standard.

2 Normative references

The following standards contain provisions which, through reference in this text, constitute provisions of this International Standard. At the time of publication, the editions indicated were valid. All standards are subject to revision, and parties to agreements based on this International Standard are encouraged to investigate the possibility of applying the most recent editions of the standards indicated below. Members of IEC and ISO maintain registers of currently valid International Standards.

ISO 1174-1:1996, *Assembly tools for bolts and screws — Driving squares — Part 1: Driving squares for hand socket tools.*

ISO 6508:1986, *Metallic materials — Hardness test — Rockwell Test (scales A-B-C-D-E-F-G-H-K).*

ISO 7403:1983, *Fasteners for aerospace construction — Spline drive wrenching configuration — Metric series.*

3 Classification

The following types and classes apply:

Type I: Sockets

- Class A: Regular
- Class B: Long
- Class C: Universal joint

Type II: Box wrench, double head, 15° offset

- Class D: Short length
- Class E: Regular length
- Class F: Long length

4 Dimensions

Female square dimensions shall conform to ISO 1174-1.

Spline drive size shall conform to ISO 7403. Socket dimensions shall conform to the dimensions given in tables 1, 2, 3 and 5. Wrench dimensions shall conform to those given in tables 7 and 8.

5 Technical requirements

5.1 Hardness

The sockets and wrenches shall have a hardness of 40 HRC to 54 HRC when tested in accordance with the conditions specified in ISO 6508.

5.2 Test mandrels

Mandrels shall be hardened to 55 HRC minimum and have smoothly finished wrench engagement surfaces. Mandrel engagement lengths shall conform to tables 4 and 6 for the sockets, and to table 7 for the wrenches. The spline mandrels shall conform to the minimum dimensions specified in ISO 7403 with tolerance h8.

5.3 Endurance test

A socket or wrench, when tested, shall be capable of withstanding 2 000 applications of the torque cyclic fatigue load when engaged with a spline mandrel. Cyclic load shall be applied at a rate of 60 cycles per minute maximum. The sample tool shall be capable of withstanding the proof load following the cyclic load test.

6 Designation

A socket or universal joint for spline drive according to this International Standard shall be designated by

- a) "Socket";
- b) reference to this International Standard;
- c) nominal dimension of driving square, in millimetres;
- d) nominal size of spline drive, in millimetres;
- e) class.

EXAMPLES

Socket for spline drive of class B with a 6,3 mm driving square and nominal wrenching size of 10 mm is designated as follows:

Socket ISO 10914 - 6,3 × 10 - B

Universal joint (class C) for spline drive with a 12,5 mm driving square and nominal wrenching size of 18 mm is designated as follows:

Socket ISO 10914 - 12,5 × 18 - C

A box wrench, double head, 15° offset, for spline drive according to this International Standard shall be designated by

- "Box wrench";
- reference to this International Standard;
- pairing of nominal spline drive sizes, in millimetres;
- class.

EXAMPLE

Box wrench, double head, for spline drive of class D, with a 7 mm × 8 mm pairing of nominal spline drive size is designated as follows:

Box wrench ISO 10914 - 7 × 8 - D

7 Marking

Sockets and wrenches shall be marked, permanently and legibly, with the following information:

- name or trademark of the manufacturer (or distributor);
- nominal size of spline drive.

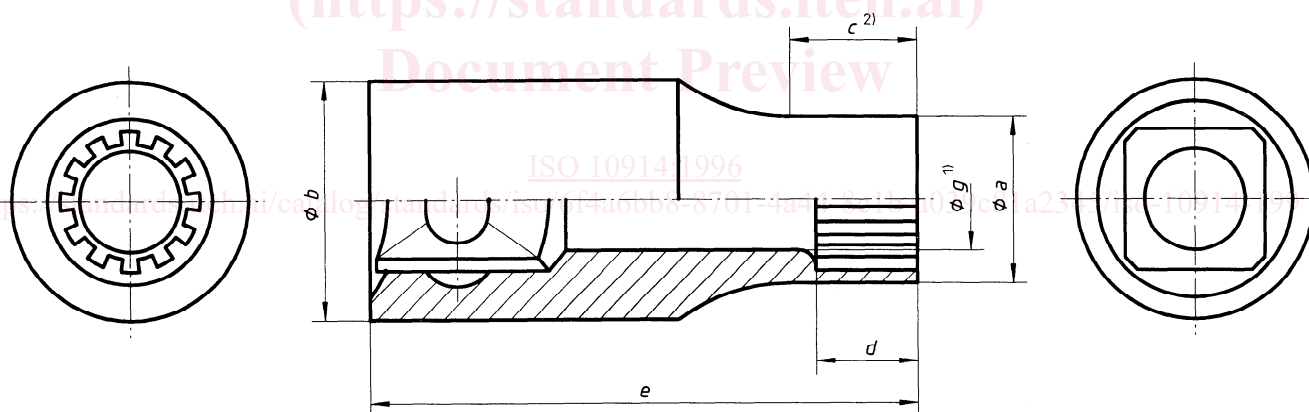

1) Bolt clearance diameter.

2) Length of cylinder of diameter a .

Figure 1 — Socket for spline drive

Table 1 — Socket dimensions, driving squares 6,3 mm and 10 mm

Dimensions in millimetres

Nominal spline drive size	Dimensions for all driving squares			Driving squares									
				6,3					10				
				Class A			Class B		Class A			Class B	
<i>a</i> max.	<i>d</i> min.	<i>g</i> min.	<i>b</i> max.	<i>c</i> min.	<i>e</i> max.	<i>c</i> min.	<i>e</i> max.	<i>b</i> max.	<i>c</i> min.	<i>e</i> max.	<i>c</i> min.	<i>e</i> max.	
5	7,8	4,8	4,5	11,2	5	26	25	50					
5,5	8,5	5,2	5	11,2	5,5	26	25,5	50					
6	9,1	5,6	5,5	11,2	6	26	26	50					
7	10,5	6,9	6,5	11,2	8	26	28	50					
8	11,8	8,4	7,5	11,8	—	26	—	50					
9	13,3	8,6	8,5	13,3	—	26	—	50	16,9	5	26	25	50
10	14,6	9,1	9,5	14,6	—	26	—	50	17	6	27,5	26	50
11	16,1	10,4	10,5						17,5	8	28,5	28	50
12	17,5	11,2	11,5						17,5	—	31	—	50
13	19,1	11,8	12,5						19,1	—	33,5	—	50
14	20,6	12,1	13,5						20,6	—	33,5	—	50

iTeh Standards
(<https://standards.iteh.ai>)
Document Preview

Table 2 — Socket dimensions, driving squares 12,5 mm and 20 mm

Dimensions in millimetres

Nominal spline drive size	Dimensions for all driving squares			Driving squares									
				12,5					20				
				Class A			Class B		Class A			Class B	
<i>a</i> max.	<i>d</i> min.	<i>g</i> min.	<i>b</i> max.	<i>c</i> min.	<i>e</i> max.	<i>c</i> min.	<i>e</i> max.	<i>b</i> max.	<i>c</i> min.	<i>e</i> max.	<i>c</i> min.	<i>e</i> max.	
12	17,5	11,2	11,5	22,2	8	33,5	52	81					
13	19,1	11,8	12,5	22,2	8	33,5	52	81					
14	20,6	12,1	13,5	22,2	8	33,5	52	81					
15	22,2	12,7	14,5	22,2	—	39,5	—	81					
16	23,2	13,6	15,5	23,2	—	39,5	—	81					
17	24,8	14	16,5	24,8	—	39,5	—	81					
18	26,2	14,7	17,5	26,2	—	39,5	—	81					
19	26,7	15,7	18,5	26,7	—	39,5	—	81	34,9	10	46	—	—
21	29,2	17	20,5	29,2	—	39,5	—	81	34,9	12	46,5	—	—
22	30,5	18	21,5	30,5	—	39,5	—	81	34,9	14	47,5	—	—
24	33	19,9	23,5						34,9	—	51	—	—
27	38,9	22,2	26,5						34,9	—	53	—	—