



Designation: D 613 – 03a

An American National Standard



Designation: 41/2000

Standard Test Method for Cetane Number of Diesel Fuel Oil¹

This standard is issued under the fixed designation D 613; the number immediately following the designation indicates the year of original adoption or, in the case of revision, the year of last revision. A number in parentheses indicates the year of last reapproval. A superscript epsilon (ϵ) indicates an editorial change since the last revision or reapproval.

1. Scope *

1.1 This test method determines the rating of diesel fuel oil in terms of an arbitrary scale of cetane numbers using a standard single cylinder, four-stroke cycle, variable compression ratio, indirect injected diesel engine.

1.2 The cetane number scale covers the range from zero (0) to 100 but typical testing is in the range of 30 to 65 cetane number.

1.3 The values for operating conditions are stated in SI units and are considered standard. The values in parentheses are the historical inch-pounds units. In addition, the engine measurements continue to be in inch-pounds units because of the extensive and expensive tooling that has been created for these units.

1.4 *This standard does not purport to address all of the safety concerns, if any, associated with its use. It is the responsibility of the user of this standard to establish appropriate safety and health practices and determine the applicability of regulatory limitations prior to use.* For more specific warning statements, see Annex A1.

2. Referenced Documents

2.1 ASTM Standards:

D 975 Specification for Diesel Fuel Oils²

D 1193 Specification for Reagent Water³

D 2500 Test Method for Cloud Point of Petroleum Products²

D 4057 Practice for Manual Sampling of Petroleum and Petroleum Products⁴

D 4175 Terminology Relating to Petroleum, Petroleum Products, and Lubricants⁴

D 4177 Practice for Automatic Sampling of Petroleum and Petroleum Products⁴

E 1 Specification for ASTM Thermometers⁵

E 456 Terminology Relating to Quality and Statistics⁶

E 542 Practice for Calibration of Laboratory Volumetric Apparatus⁷

E 832 Specification for Laboratory Filter Papers⁷

3. Terminology

3.1 Definitions:

3.1.1 *accepted reference value (ARV), n*—a value that serves as an agreed-upon reference for comparison, and which is derived as: (1) a theoretical or established value, based on scientific principles, or (2) an assigned or certified value, based on experimental work of some national or international organization, or (3) a consensus or certified value, based on collaborative experimental work under the auspices of a scientific or engineering group. **E 456**

3.1.1.1 *Discussion*—In the context of this test method, accepted reference value is understood to apply to the cetane number of specific reference materials determined empirically under reproducibility conditions by the National Exchange Group or another recognized exchange testing organization.

3.1.2 *cetane number, n*—a measure of the ignition performance of a diesel fuel oil obtained by comparing it to reference fuels in a standardized engine test. **D 4175**

3.1.2.1 *Discussion*—In the context of this test method, ignition performance is understood to mean the ignition delay of the fuel as determined in a standard test engine under controlled conditions of fuel flow rate, injection timing and compression ratio.

3.1.3 *compression ratio, n*—the ratio of the volume of the combustion chamber including the precombustion chamber with the piston at bottom dead center to the comparable volume with the piston at top dead center.

¹ This test method is under the jurisdiction of ASTM Committee D02 on Petroleum Products and Lubricants and is the direct responsibility of Subcommittee D02.01 on Combustion Characteristics.

Current edition approved May 10, 2003. Published May 2003. Originally approved in 1941. Last previous edition approved in 2001 as D 613–03.

² *Annual Book of ASTM Standards*, Vol 05.01.

³ *Annual Book of ASTM Standards*, Vol 11.01.

⁴ *Annual Book of ASTM Standards*, Vol 05.02.

⁵ *Annual Book of ASTM Standards*, Vol 14.03.

⁶ *Annual Book of ASTM Standards*, Vol 14.02.

⁷ *Annual Book of ASTM Standards*, Vol 14.04.

*A Summary of Changes section appears at the end of this standard.

3.1.4 *ignition delay, n*—that period of time, expressed in degrees of crank angle rotation, between the start of fuel injection and the start of combustion.

3.1.5 *injection timing (injection advance), n*—that time in the combustion cycle, measured in degrees of crank angle, at which fuel injection into the combustion chamber is initiated.

3.1.6 *repeatability conditions, n*—conditions where independent test results are obtained with the same method on identical test items in the same laboratory by the same operator using the same equipment within short intervals of time.

E 456

3.1.6.1 *Discussion*—In the context of this method, a short time interval between two ratings on a sample fuel is understood to be not less than the time to obtain at least one rating on another sample fuel between them but not so long as to permit any significant change in the sample fuel, test equipment, or environment.

3.1.7 *reproducibility conditions, n*—conditions where test results are obtained with the same method on identical test items in different laboratories with different operators using different equipment.

E 456

3.2 *Definitions of Terms Specific to This Standard:*

3.2.1 *cetane meter (ignition delay meter), n*—the electronic instrument which displays injection advance and ignition delay derived from input pulses of multiple transducers (pickups).

3.2.2 *Check Fuels, n*—for quality control testing, a diesel fuel oil of selected characteristics having a cetane number accepted reference value determined by round-robin testing under reproducibility conditions.

3.2.3 *combustion pickup, n*—pressure transducer exposed to cylinder pressure to indicate the start of combustion.

3.2.4 *handwheel reading, n*—an arbitrary numerical value, related to compression ratio, obtained from a micrometer scale that indicates the position of the variable compression plug in the precombustion chamber of the engine.

3.2.5 *injector opening pressure, n*—the fuel pressure that overcomes the resistance of the spring which normally holds the nozzle pintle closed, and thus forces the pintle to lift and release an injection spray from the nozzle.

3.2.6 *injector pickup, n*—transducer to detect motion of the injector pintle, thereby indicating the beginning of injection.

3.2.7 *primary reference fuels, n*— *n*-cetane, heptamethyl nonane (HMN) and volumetrically proportioned mixtures of these materials which now define the cetane number scale by the relationship:

$$\text{Cetane Number} = \% n\text{-cetane} + 0.15 (\% \text{HMN}) \quad (1)$$

3.2.7.1 *Discussion*—In the context of this test method, the arbitrary cetane number scale was originally defined as the volume percent of *n*-cetane in a blend with alpha-methylnaphthalene (AMN) where *n*-cetane had an assigned value of 100 and AMN an assigned value of zero (0). A change from alpha-methylnaphthalene to heptamethylnonane as the low cetane ingredient was made in 1962 to utilize a material of better storage stability and availability. Heptamethylnonane was determined to have a cetane number accepted reference value (CN_{ARV}) of 15 based on engine testing by the ASTM Diesel National Exchange Group, using blends of *n*-cetane and AMN as primary reference fuels.

3.2.7.2 *Discussion*—In the context of this test method, the Diesel National Exchange Group of Subcommittee D02.01⁸ is composed of petroleum industry, governmental, and independent laboratories. It conducts regular monthly exchange sample analyses to generate precision data for this engine test standard and determines the CN_{ARV} of reference materials used by all laboratories.

3.2.8 *reference pickups, n*—transducer(s) mounted over the flywheel of the engine, triggered by a flywheel indicator, used to establish a top-dead-center (tdc) reference and a time base for calibration of the ignition delay meter.

3.2.9 *secondary reference fuels, n*—volumetrically proportioned blends of two selected, numbered, and paired hydrocarbon mixtures designated *T Fuel* (high cetane) and *U Fuel* (low cetane) that have been rated by the ASTM Diesel National Exchange Group using primary reference fuels to determine a cetane number accepted reference value for each individually and for various combinations of the two.

4. Summary of Test Method

4.1 The cetane number of a diesel fuel oil is determined by comparing its combustion characteristics in a test engine with those for blends of reference fuels of known cetane number under standard operating conditions. This is accomplished using the bracketing handwheel procedure which varies the compression ratio (handwheel reading) for the sample and each of two bracketing reference fuels to obtain a specific ignition delay permitting interpolation of cetane number in terms of handwheel reading.

5. Significance and Use

5.1 The cetane number provides a measure of the ignition characteristics of diesel fuel oil in compression ignition engines.

5.2 This test method is used by engine manufacturers, petroleum refiners and marketers, and in commerce as a primary specification measurement related to matching of fuels and engines.

5.3 Cetane number is determined at constant speed in a precombustion chamber type compression ignition test engine. The relationship of test engine performance to full scale, variable speed, variable load engines is not completely understood.

5.4 This test method may be used for unconventional fuels such as synthetics, vegetable oils, and the like. However, the relationship to the performance of such materials in full scale engines is not completely understood.

6. Interferences

6.1 (**Warning**—Avoid exposure of sample fuels and reference fuels to sunlight or fluorescent lamp UV emissions to minimize induced chemical reactions that can affect cetane number ratings.)⁹

⁸ Bylaws governing ASTM Subcommittee D02.01 on Combustion Characteristics are available from the subcommittee or from ASTM International.

⁹ Supporting data have been filed at ASTM International Headquarters and may be obtained by requesting Research Report RR: D02-1502.

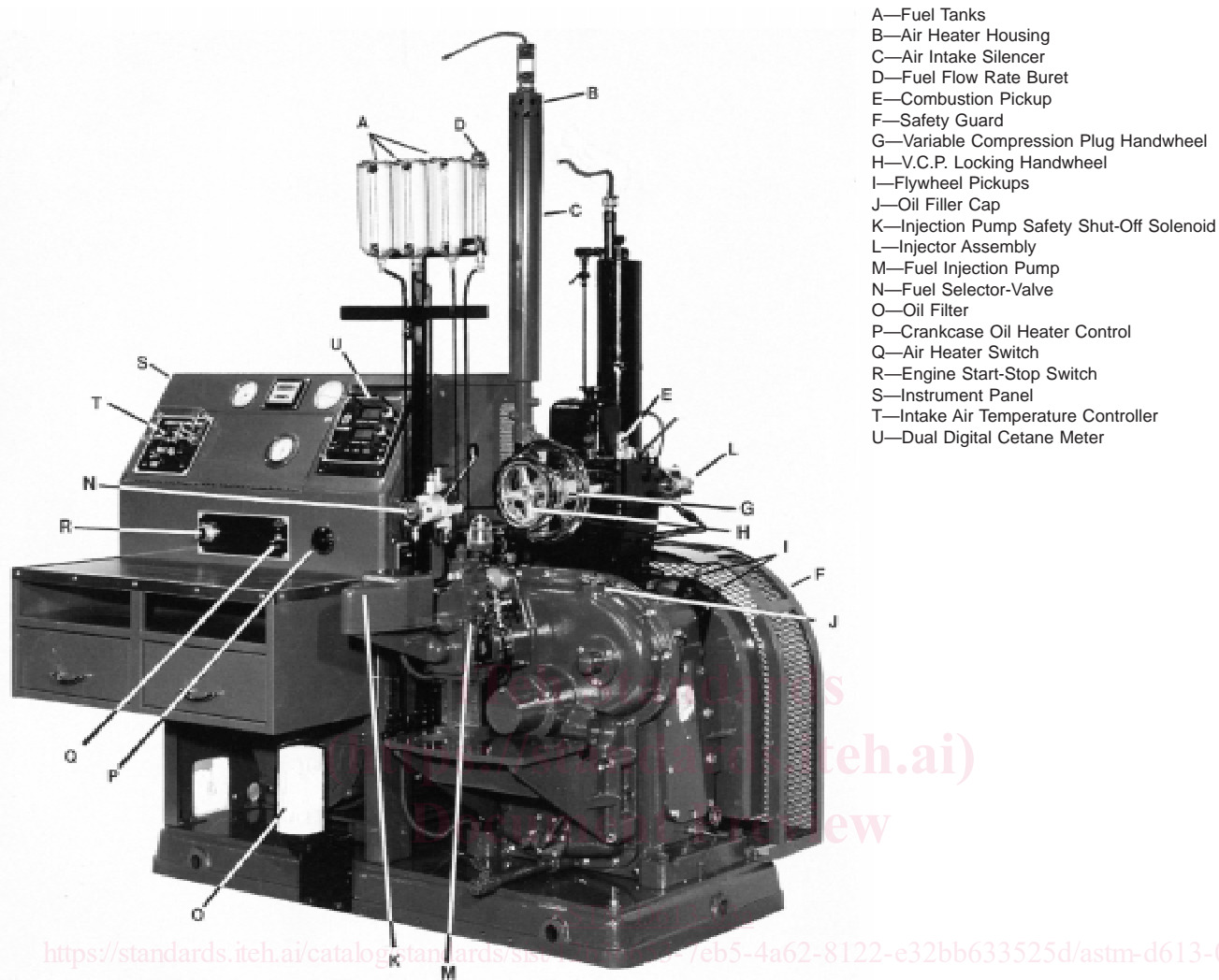

FIG. 1 Cetane Method Test Engine Assembly

6.1.1 Exposure of these fuels to UV wavelengths shorter than 550 nm for a short period of time may significantly affect cetane number ratings.

6.2 Certain gases and fumes present in the area where the cetane test engine is located may have a measurable effect on the cetane number test result.

6.3 This test method is not suitable for rating diesel fuel oils with fluid properties that interfere with unimpeded gravity flow of fuel to the fuel pump or delivery through the injector nozzle.

7. Apparatus

7.1 *Engine Equipment*¹⁰—This test method uses a single cylinder engine which consists of a standard crankcase with fuel pump assembly, a cylinder with separate head assembly of

the precombustion type, thermal syphon recirculating jacket coolant system, multiple fuel tank system with selector valving, injector assembly with specific injector nozzle, electrical controls, and a suitable exhaust pipe. The engine is belt connected to a special electric power-absorption motor which acts as a motor driver to start the engine and as a means to absorb power at constant speed when combustion is occurring (engine firing). See Fig. 1.

7.1.1 See Annex A2 for detail and description of all critical, non-critical and equivalent engine equipment.

7.2 *Instrumentation*¹⁰—This test method uses an electronic instrument to measure injection and ignition delay timing as well as conventional thermometry, gages and general purpose meters.

7.2.1 A *Cetane Meter*, (Ignition Delay Meter) is critical and shall be used for this test method.

7.2.2 See Annex A3 for detail and description of all critical, non-critical and equivalent instrumentation.

¹⁰ Engine equipment and instrumentation are available from the single source manufacturer, Waukesha Engine, Dresser Inc., 1000 West St. Paul Avenue, Waukesha, WI 53188. Waukesha Engine also has CFR engine authorized sales and service organizations in selected geographical areas.

7.3 Reference Fuel Dispensing Equipment—This test method requires repeated volumetric blending of two secondary reference fuel materials on an as-needed basis. Measurement shall be performed accurately because rating error is proportional to blending error. A set of two burets or accurate volumetric ware shall be used and the desired batch quantity shall be collected in an appropriate container and thoroughly mixed before being introduced to the engine fuel system.

7.3.1 Calibrated burets or volumetric ware having a capacity of 400 or 500 mL and a maximum volumetric tolerance of $\pm 0.2\%$ shall be used. Calibration shall be verified in accordance with Practice E 542.

7.3.1.1 Calibrated burets shall be outfitted with a dispensing valve and delivery tip to accurately control dispensed volume. The delivery tip shall be of such size and design that shutoff tip discharge does not exceed 0.5 mL.

7.3.1.2 The rate of delivery from the dispensing system shall not exceed 500 mL per 60 s.

7.3.1.3 The set of reference fuel burettes and the system components that fill them shall be installed so that all components of each volumetric batch or blend are dispensed at the same temperature.

7.3.1.4 Amber glass burettes or burettes with suitable opaque external shielding are recommended to minimize exposure of the reference fuel components to UV light.

7.3.2 See Appendix X1 for typical dispensing system information.

7.4 Auxiliary Apparatus:

7.4.1 Injector Nozzle Tester—The injector nozzle assembly shall be checked whenever the injector nozzle is removed and reassembled to ensure the initial pressure at which fuel is discharged from the nozzle is properly set. It is also important to inspect the type of spray pattern. Commercial injector nozzle testers which include a lever-operated pressure cylinder, fuel reservoir and pressure gage are available from several sources as common diesel engine maintenance equipment.

7.4.2 Special Maintenance Tools—A number of specialty tools and measuring instruments should be utilized for easy, convenient and effective maintenance of the engine and testing equipment. Lists and descriptions of these tools and instruments are available from the manufacturers of the engine equipment and those organizations offering engineering and service support for this test method.

8. Reagents and Reference Materials

8.1 Cylinder Jacket Coolant—Water shall be used in the cylinder jacket for laboratory locations where the resultant boiling temperature shall be $100 \pm 2^\circ\text{C}$ ($212 \pm 3^\circ\text{F}$). Water with commercial glycol-based antifreeze added in sufficient quantity to meet the boiling temperature requirement shall be used when laboratory altitude dictates. A commercial multi-functional water treatment material should be used in the coolant to minimize corrosion and mineral scale that can alter heat transfer and rating results.

8.1.1 Water shall be understood to mean reagent water conforming to Type IV of Specification D 1193.

8.2 Engine Crankcase Lubricating Oil—An SAE 30 viscosity grade oil meeting service classification SF/CD or SG/CE shall be used. It shall contain a detergent additive and have a

kinematic viscosity of 9.3 to 12.5 cSt (mm^2 per s) at 100°C (212°F) and a viscosity index of not less than 85. Oils containing viscosity index improvers shall not be used. Multi-graded oils shall not be used. (**Warning**—Lubricating oil is combustible, and its vapor is harmful. See Annex A1.)

8.3 Primary Reference Fuels—(**Warning**—Primary Reference Fuel—Combustible. Vapor Harmful. See Annex A1.)¹¹

8.3.1 n-Cetane (n-hexadecane)—With a minimum purity of 99.0 % as determined by chromatographic analysis shall be used as the designated 100 cetane number component.

8.3.2 Heptamethylnonane (2,2,4,4,6,8,8-heptamethylnonane)—With a minimum purity of 98 % as determined by chromatographic analysis shall be used as the designated 15 cetane number component.

8.4 Secondary Reference Fuels¹²—(**Warning**—Secondary Reference fuel—Combustible. Vapor Harmful. See Annex A1.)

8.4.1 T Fuel—Diesel fuel with a CN_{ARV} typically in the range of 73 to 75.

8.4.2 U Fuel—Diesel fuel with a CN_{ARV} typically in the range of 20 to 22.

8.4.3 Storage and use of *T Fuel* and *U Fuel* should be at temperatures above 0°C (32°F) to avoid potential solidification, particularly of *T Fuel*. Before a container that has been stored at low temperature is placed in service, it should be warmed to a temperature of at least 15°C (27°F) above its Cloud Point. (See Test Method D 2500.) It should be held at this temperature for a period of at least 30 min and then the container should be thoroughly remixed.

8.5 Check Fuels¹³—Diesel fuel oils typical of Specification D 975 grade No. 2-D distillate fuel oil. (**Warning**—Check Fuel—Combustible. Vapor Harmful. See Annex A1.)

8.5.1 Low Cetane Check Fuel—With a CN_{ARV} typically in the range of 38 to 42.

8.5.2 High Cetane Check Fuel—With a CN_{ARV} typically in the range of 50 to 55.

9. Sampling

9.1 Collect samples in accordance with Practice D 4057 or D 4177.

9.1.1 Protection from Light—Collect and store sample fuels in an opaque container such as a dark brown glass bottle, metal can, or a minimally reactive plastic container to minimize exposure to UV emissions from sources such as sunlight or fluorescent lamps.

9.2 Fuel Temperature—Samples shall be brought to room temperature typically 18 to 32°C (65 to 90°F) before engine testing.

9.3 Filtration—Samples may be filtered through a Type I, Class A filter paper at room temperature and pressure before engine testing. See Specification E 832.

¹¹ Primary Reference Fuels are available from a single supplier in the U.S., Humphrey Chemical Co., Devine Street, North Haven, CT 06473.

¹² Secondary Reference and Check Fuels are available from a single supplier, Chevron Phillips Chemical Company LP, 1301 McKinney, Suite 2130, Houston, TX 77010-3030.

¹³ Blend Tables for batches of *T Fuel* and *U Fuel* can be obtained from the fuel supplier or by requesting Research Report RR: D02-1302 from ASTM International.

10. Basic Engine and Instrument Settings and Standard Operating Conditions

10.1 *Installation of Engine Equipment and Instrumentation*—Installation of the engine and instrumentation requires placement of the engine on a suitable foundation and hook-up of all utilities. Engineering and technical support for this function is required, and the user shall be responsible to comply with all local and national codes and installation requirements.

10.1.1 Proper operation of the test engine requires assembly of a number of engine components and adjustment of a series of engine variables to prescribed specifications. Some of these settings are established by component specifications, others are established at the time of engine assembly or after overhaul and still others are engine running conditions that must be observed or determined by operator adjustment, or both, during the testing process.

10.2 Conditions Based on Component Specifications:

10.2.1 *Engine Speed*— 900 ± 9 rpm, when the engine is operating with combustion with a maximum variation of 9 rpm occurring during a rating. Engine speed when combustion is occurring shall not be more than 3 rpm greater than that for motoring without combustion.

10.2.2 *Valve Timing*—The engine uses a four-stroke cycle with two crankshaft revolutions for each complete combustion cycle. The two critical valve events are those that occur near top-dead-center (tdc); intake valve opening and exhaust valve closing. See Annex A4 for Camshaft Timing and Valve Lift Measurement Procedure.

10.2.2.1 Intake valve opening shall occur $10.0 \pm 2.5^\circ$ after-top-dead-center (atdc) with closing at 34° after-bottom-dead-center (abdc) on one revolution of the crankshaft and flywheel.

10.2.2.2 Exhaust valve opening shall occur 40° before-bottom-dead-center (bbdc) on the second revolution of the crankshaft or flywheel with closing at $15.0 \pm 2.5^\circ$ after-top-dead-center on the next revolution of the crankshaft or flywheel.

10.2.3 *Valve Lift*—Intake and exhaust cam lobe contours, while different in shape, shall have a contour rise of 6.223 to 6.350 mm (0.245 to 0.250 in.) from the base circle to the top of the lobe so that the resulting valve lift shall be 6.045 ± 0.05 mm (0.238 ± 0.002 in.). See Annex A4 for Camshaft Timing and Valve Lift Measurement Procedure.

10.2.4 *Fuel Pump Timing*—Closure of the pump plunger inlet port shall occur at a flywheel crank angle between 300 and 306° on the engine compression stroke when the fuel flow-rate-micrometer is set to a typical operating position and the variable timing device lever is at full advance (nearest to operator). See Annex A4 for detailed instructions on setting and checking the fuel pump timing.

10.2.5 *Fuel Pump Inlet Pressure*—A minimum fuel head established by assembly of the fuel tanks (storage reservoirs) and flow rate measuring buret so that the discharge from them is 635 ± 25 mm (25 ± 1 in.) above the centerline of the fuel injection pump inlet.

10.3 Assembly Settings and Operating Conditions:

10.3.1 *Direction of Engine Rotation*—Clockwise rotation of the crankshaft when observed from the front of the engine.

10.3.2 *Injection Timing*— 13.0° before-top-dead-center (bt dc), for the sample and reference fuels.

10.3.3 *Injector Nozzle Opening Pressure*— 10.3 ± 0.34 MPa (1500 ± 50 psi).

10.3.4 *Injection Flow Rate*— 13.0 ± 0.2 mL/min (60 ± 1 s per 13.0 mL).

10.3.5 *Injector Coolant Passage Temperature*— $38 \pm 3^\circ\text{C}$ ($100 \pm 5^\circ\text{F}$).

10.3.6 Valve Clearances:

10.3.6.1 *Engine Stopped and Cold*—Clearance between the valve stem and valve rocker half-ball set to the following approximate measurements upon assembly before the engine is operated will typically provide the controlling engine running and hot clearance:

Intake Valve	0.075 mm (0.004 in.)
Exhaust Valve	0.330 mm (0.014 in.)

These clearances should ensure that both valves have sufficient clearance to cause valve seating during engine warmup. The adjustable-length valve push-rods shall be set so that the valve rocker adjusting screws have adequate travel to permit the final clearance setting.

10.3.6.2 *Engine Running and Hot*—The clearance for both intake and exhaust valves shall be set to 0.20 ± 0.025 mm (0.008 ± 0.001 in.), measured under standard operating conditions with the engine running at equilibrium conditions on a typical diesel fuel oil.

10.3.7 *Oil Pressure*—172 to 207 kPa (25 to 30 psi). See Annex A4 for the Adjusting Crankcase Lubricating Oil Pressure procedure.

10.3.8 *Oil Temperature*— $57 \pm 8^\circ\text{C}$ ($135 \pm 15^\circ\text{F}$).

10.3.9 *Cylinder Jacket Coolant Temperature*— $100 \pm 2^\circ\text{C}$ ($212 \pm 3^\circ\text{F}$).

10.3.10 *Intake Air Temperature*— $66 \pm 0.5^\circ\text{C}$ ($150 \pm 1^\circ\text{F}$).

10.3.11 *Basic Ignition Delay*— 13.0° for the sample and reference fuels.

10.3.12 Cylinder Jacket Coolant Level:

10.3.12.1 *Engine Stopped and Cold*—Treated water/coolant added to the cooling condenser—cylinder jacket to a level just observable in the bottom of the condenser sight glass will typically provide the controlling engine running and hot operating level.

10.3.12.2 *Engine Running and Hot*—Coolant level in the condenser sight glass shall be within ± 1 cm (0.4 in.) of the LEVEL HOT mark on the coolant condenser.

10.3.13 Engine Crankcase Lubricating Oil Level:

10.3.13.1 *Engine Stopped and Cold*—Oil added to the crankcase so that the level is near the top of the sight glass will typically provide the controlling engine running and hot operating level.

10.3.13.2 *Engine Running and Hot*—Oil level shall be approximately mid-position in the crankcase oil sight glass.

10.3.14 *Crankcase Internal Pressure*—As mentioned by a gage or manometer connected to an opening to the inside of the crankcase through a snubber orifice to minimize pulsations, the pressure shall be less than zero (a vacuum) and typically from

25 to 150 mm (1 to 6 in.) of water less than atmospheric pressure. Vacuum shall not exceed 255 mm (10 in.) of water.

10.3.15 *Exhaust Back Pressure*—As measured by a gage or manometer connected to an opening in the exhaust surge tank or main exhaust stack through a snubber orifice to minimize pulsations, the static pressure should be as low as possible, but shall not create a vacuum nor exceed 254 mm (10 in.) of water differential in excess of atmospheric pressure.

10.3.16 *Exhaust and Crankcase Breather System Resonance*—The exhaust and crankcase breather piping systems shall have internal volumes and be of such length that gas resonance does not result. See Appendix X2 for a suitable procedure to determine if resonance exists.

10.3.17 *Piston Over-Travel*—Assembly of the cylinder to the crankcase shall result in the piston protruding above the top of the cylinder surface 0.381 ± 0.025 mm (0.015 ± 0.001 in.) when the piston is at top-dead-center. Proper positioning is accomplished through the use of plastic or paper gaskets, available in several thicknesses and selected by trial and error for assembly between the cylinder and crankcase deck.

10.3.18 *Belt Tension*—The belts connecting the flywheel to the absorption motor shall be tightened, after an initial break-in, so that with the engine stopped, a 2.25 kg (5 lb) weight suspended from one belt half way between the flywheel and motor pulley shall depress the belt approximately 12.5 mm (0.5 in.).

10.3.19 *Setting Injector Nozzle Assembly Pressure and Spray Pattern Check*—(Warning—Personnel shall avoid contact with the spray pattern from injector nozzles because of the high pressure which can penetrate the skin. Spray pattern performance checks shall be made in a hood or where adequate ventilation insures that inhalation of the vapors is avoided.)

10.3.19.1 *Injector Opening or Release Pressure*—The pressure adjusting screw is adjustable and shall be set to release fuel at a pressure of 10.3 ± 0.34 MPa (1500 ± 50 psi). Check this setting using an injector nozzle bench tester, each time the nozzle is reassembled and after cleaning. Use of a commercial injector nozzle bench tester is recommended. See Annex A4 for procedural detail.

10.3.19.2 *Injector Spray Pattern*—Check the spray pattern for symmetry and characteristic by inspection of the impression of a single injection made on a piece of filter paper or other slightly absorbent material placed at a distance of approximately 7.6 cm (3 in.) from the nozzle. A typical spray pattern is illustrated in Fig. 2.

10.3.20 *Indexing Handwheel Reading*—Handwheel readings are a simple and convenient indication of engine compression ratio which is a critical variable in the cetane method

of test. The actual compression ratio is not important but an indication of compression ratio which relates to cetane number is a useful guide for selecting reference fuels to bracket the sample of diesel fuel oil. The following procedure shall be used to index the handwheel reading when the engine is new or anytime the matched handwheel assembly/cylinder head combination is interchanged or mechanically reassembled. See Appendix X3 for handwheel assembly reworking instructions.

10.3.20.1 *Handwheel Micrometer Drum and Scale Setting*—Refer to Table 1 to select the appropriate handwheel reading to be used in aligning the drum and scale.

10.3.20.2 *Basic Setting of Variable Compression Plug*—Position the variable compression plug so that the flat surface is just visible and exactly in line with the edge of the threads of the combustion pickup hole, as verified with a straightedge.

10.3.20.3 *Setting Handwheel Reading*—Tighten the small locking handwheel snugly by hand to ensure that the variable compression plug is held in place in the bore. Loosen the lock nut of the large handwheel and remove the locking L-shaped key. Turn the large handwheel so that the edge of the drum is in alignment with the 1.000 graduation on the horizontal scale. Reinstall the L-shaped key in the nearest keyway slot of the large handwheel with the shorter leg in the handwheel. A slight shifting of the handwheel to achieve slot line-up will not affect the indexing. Tighten the lock nut hand-tight to hold the key in place. Remove the locating screw from the drum and rotate the drum so that the zero graduation mark is in line with the selected reading from Table 1. Locate the screw hole in the drum which lines up with the handwheel hub hole and reinstall the locating screw. Wrench tighten the large handwheel lock nut and recheck that the variable compression plug is properly positioned and the handwheel reading is in accordance with the value in Table 1.

10.3.21 *Basic Compression Pressure*—At a handwheel reading of 1.000, the compression pressure for an engine operated at standard barometric pressure of 760 mm Hg. (29.92 in. Hg) shall be 3275 ± 138 kPa (475 ± 20 psi) when read as quickly as possible after shutdown of the engine which had been at standard operating conditions. If the condition is not within limits, recheck the basic handwheel setting and, if necessary, perform mechanical maintenance. See Annex A4 for the Checking Compression Pressure procedure.

10.3.21.1 For engines operated at other than standard barometric pressure, the compression pressure will typically be in proportion to the ratio of the local barometric pressure divided by standard barometric pressure. As an example, an engine located where the barometric pressure is 710 mm Hg would be expected to have a compression pressure of approximately 3060 ± 138 kPa (444 ± 20 psi). (Warning—In addition to other precautions, compression pressure testing using a compression pressure gage should be completed in as short a period

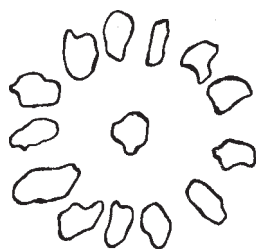

FIG. 2 Typical Injector Spray Pattern

TABLE 1 Handwheel Setting for Various Cylinder Bore Diameters

Cylinder Diameter, in.		Handwheel Reading
3.250	(Standard Bore)	1.000
3.260	(Rebored 0.010 in. Oversize)	0.993
3.270	(Rebored 0.020 in. Oversize)	0.986
3.280	(Rebored 0.030 in. Oversize)	0.978

of time as possible to avoid the possibility of combustion occurrence due to the presence of any small amount of oil in the gage or combustion chamber.)

$$\begin{aligned} \text{Compression Pressure (LocalBaro.,mmHg)} \\ = 3275 \text{ kPa} \times \text{Local Baro./Standard Baro.} \end{aligned} \quad (2)$$

$$\begin{aligned} \text{Example: Compression Pressure}_{710\text{mmHg}} \\ = 3275 \times 710/760 = 3060 \text{ kPa} \end{aligned}$$

10.3.22 *Fuel Pump Lubricating Oil Level*—With the engine stopped, sufficient engine crankcase lubricating oil shall be added to the pump sump so that the level is at the mark on the dip stick. (**Warning**—As a result of engine operation, especially when the pump barrel/plunger assembly begins to wear, the level in the sump will increase due to fuel dilution as observed through a clear plastic side plate on the pump housing. When the level rises appreciably, the sump should be drained and a fresh charge of oil added.)

10.3.23 *Fuel Pump Timing Gear Box Oil Level*—With the engine stopped, unplug the openings on the top and at the mid-height of either side of the gear box. Add sufficient engine crankcase lubricating oil through the top hole to cause the level to rise to the height of the side opening. Replug both openings. (**Warning**—The pump and timing gear box oil sumps are not connected to each other and the lubrication for the two is independent.)

10.3.24 *Instrumentation*—Positioning of the reference pickups and injector pickup is important to ensure that timing of the injection and ignition delay functions is uniform and correct.

10.3.24.1 *Setting Reference Pickups*—These two pickups are identical and interchangeable. They are installed in a bracket positioned over the flywheel so that they clear the flywheel indicator which triggers them.

10.3.24.2 Position each pickup in the bracket so that it is properly referenced to the flywheel indicator in accordance with the instructions supplied with the specific pickup.

10.3.24.3 Measurement of pickup to flywheel indicator clearance, if required, shall be made using a non-magnetic feeler gage.

10.3.25 *Setting Injector Pickup Gap*—Set the air gap to typically 1 mm (0.040 in.) with the engine stopped.

10.3.25.1 Individual pickups may require more or less air gap to obtain steady meter operation when the engine is ultimately running but too little gap can cause the ignition delay angle display to drive off scale.

11. Calibration and Engine Qualification

11.1 *Engine Compliance*—It is assumed that the engine has been commissioned and that all settings and operating variables are at equilibrium and in compliance with basic engine and instrument settings and standard operating conditions.

11.1.1 Engine warmup requires typically 1 h to ensure that all critical variables are stable.

11.2 *Checking Performance on Check Fuels*—This engine test does not have any satisfactory standardization fuel blend or blends to qualify the engine. The Check Fuels are the most helpful means available to permit judgement of good performance.

11.2.1 Test one or more of the Check Fuels.

11.2.2 Engine performance is judged satisfactory if the cetane rating obtained on a Check Fuel is within the Check Fuel tolerance limits calculated as follows:

$$\text{Tolerance Limits} = CN_{ARV} \pm 1.5 \times S_{ARV} \quad (3)$$

where:

CN_{ARV} = the cetane number accepted reference value of the Check Fuel,

1.5 = a selected tolerance limit factor (K) for normal distributions,

S_{ARV} = the standard deviation of the Check Fuel data used to determine CN_{ARV} .

11.2.2.1 *In the context of this test method*, the statistical tolerance limit factor (K), based on a sample size (n), permits an estimation of the percentage of engines that would be able to rate the Check Fuel within the calculated tolerance limits. Based on a data set of 17 to 20 ratings used to determine the Check Fuel CN_{ARV} , and a value of $K = 1.5$, it is estimated that in the long run, in 19 cases out of 20, at least 70 % of the engines would rate the Check Fuel within the calculated tolerance limits.

11.2.3 If the results are outside this tolerance range, the engine is not acceptable for rating samples and a check of all operating conditions is warranted followed by mechanical maintenance which may require critical parts replacement. The injector nozzle can be a very critical factor and this should be the first item checked or replaced to achieve rating compliance.

12. Procedure

12.1 *Bracketing by Handwheel Procedure*—See Appendix X2 for the details of engine operation and the adjustment of each of the individual operating variables.

12.1.1 Check that all engine operating conditions are in compliance and equilibrated with the engine running on a typical diesel fuel oil. (**Warning**—In addition to other precautions, always position the ignition delay meter (Mark II and earlier models) to CALIBRATE before proceeding with fuel switching so that violent meter needle full-scale pegging does not occur. Calibration adjustment should be checked before each rating but never changed during a rating.)

12.1.2 Introduce the sample to an empty fuel tank, rinse the fuel buret, purge any air from the fuel line to the pump and position the fuel-selector valve to operate the engine on this fuel. (**Warning**—Sample and Fuel—Combustible. Vapor Harmful. See Annex A1.)

12.1.3 *Fuel Flow Rate*—Check the fuel flow rate and adjust the flow-rate-micrometer of the fuel pump to obtain 13 mL per min consumption. The final flow rate measurement shall be made over a full 60 ± 1 s period. Note the flow-rate-micrometer reading for reference.

12.1.4 *Fuel Injection Timing*—After establishing the fuel flow rate, adjust the injection-timing-micrometer of the fuel pump assembly to obtain a $13.0 \pm 0.2^\circ$ injection advance reading. Note the injection-timing-micrometer reading for reference.

12.1.5 *Ignition Delay*—Adjust the handwheel to change the compression ratio and obtain a $13.0 \pm 0.2^\circ$ ignition delay reading. Make the final handwheel adjustment in the clockwise

direction (viewed from front of engine) to eliminate backlash in the handwheel mechanism and a potential error.

12.1.6 *Equilibration*—It is important to achieve stable injection advance and ignition delay readings.

12.1.6.1 Stable readings should typically occur within 5 to 10 min.

12.1.6.2 The time used for the sample and each of the reference fuels should be consistent and shall not be less than 3 min.

12.1.7 *Handwheel Reading*—Observe and record the handwheel reading as the representative indication of the combustion characteristic for this fuel sample.

12.1.8 *Reference Fuel No. 1*—Select a secondary reference fuel (*T Fuel* and *U Fuel*) blend close to the estimated cetane number of the sample.

NOTE 1—The handwheel reading vs cetane number relationship based on this procedure is engine and overhaul dependent but it can be established for each engine as testing experience is gained after each overhaul. A plot or table of handwheel readings provides a simple guide to selection of the reference fuel.

12.1.8.1 Prepare a fresh 400 or 500 mL batch of the selected reference blend.

12.1.8.2 Introduce Reference Fuel No. 1 to one of the unused fuel tanks taking care to flush the fuel lines in the same manner as noted for the sample.

12.1.8.3 Perform the same adjustment and measurement steps used for the sample and record the resulting handwheel reading.

12.1.9 *Reference Fuel No. 2*—Select another secondary reference fuel blend which can be expected to result in a handwheel reading that causes the two reference fuel handwheel readings to bracket that for the sample. The difference between the two reference fuel blends shall not exceed 5.5 cetane numbers. Typically, blends differing by 5 volume percent *T Fuel* will span about 2.7 cetane numbers and those differing by 10 volume percent *T Fuel* will span about 5.3 cetane numbers.

12.1.9.1 Prepare a fresh 400 or 500 mL batch of the selected reference fuel blend.

12.1.9.2 Introduce Reference Fuel No. 2 to the third fuel tank taking care to flush the fuel lines in the same manner as noted for the sample.

12.1.9.3 Perform the same adjustment and measurement steps used for the sample and first reference fuel and record the resulting handwheel reading.

NOTE 2—Typically, the fuel-flow-rate should be the same for both reference fuels because they are sufficiently similar in composition.

12.1.9.4 If the handwheel reading for the sample is bracketed by those of the reference fuel blends, continue the test; otherwise try an additional reference fuel blend(s) until this requirement is satisfied.

12.1.10 *Repeat Readings*—After operation on a satisfactory second reference fuel blend, perform the necessary steps to rerun Reference Fuel No. 1, then the sample and finally Reference Fuel No. 2. For each fuel, be certain to check all parameters carefully and allow operation to reach equilibrium

before recording the handwheel readings. The fuel switching shall be as illustrated in Fig. 3 Sample and Reference Fuel Reading Sequence A.

12.1.10.1 If a sample is tested immediately following one for which the Reference Fuel No. 2 will be applicable, that reference fuel handwheel reading can be utilized for the new sample. The fuel switching shall thus be as illustrated in Fig. 3, Sample and Reference Fuel Reading Sequence B.

13. Calculation of Cetane Number

13.1 Calculate the average handwheel readings for the sample and each of the reference fuel blends.

13.2 Calculate the cetane number by interpolation of these average handwheel readings proportioned to the cetane numbers of the bracketing reference fuel blends in accordance with Eq 4. See Fig. 4.

13.2.1 For the Handwheel Bracketing Procedure:

$$CN_S = CN_{LRF} + \left(\frac{HW_S - HW_{LRF}}{HW_{HRF} - HW_{LRF}} \right) (CN_{HRF} - CN_{LRF}) \quad (4)$$

where:

- CN_S = cetane number of sample,
- CN_{LRF} = cetane Number of low reference fuel,
- CN_{HRF} = cetane number of high reference fuel,
- HW_S = handwheel reading of sample,
- HW_{LRF} = handwheel reading of low reference fuel, and
- HW_{HRF} = handwheel reading of high reference fuel.

13.2.2 Do not interpolate using reference fuel blend volume percent of *T Fuel* values and convert that equivalent percent to cetane number.

13.3 Round the calculated cetane number to the nearest tenth. Any cetane number ending in exactly 5 in the second decimal place shall be rounded to the nearest even tenth number; for example, round 35.55 and 35.65 to 35.6 cetane number.

SAMPLE AND REFERENCE FUEL READING SEQUENCE A

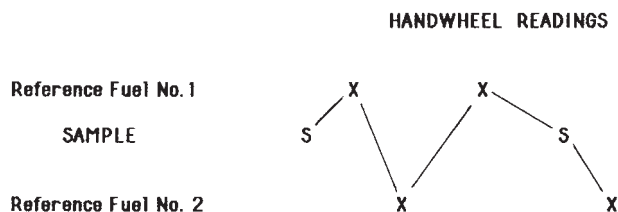

SAMPLE AND REFERENCE FUEL READING SEQUENCE B

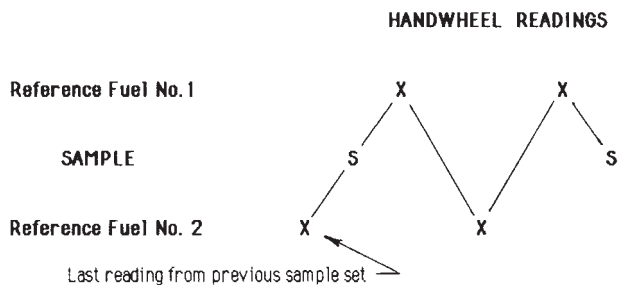
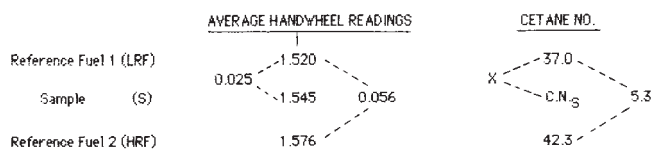

FIG. 3 Sample and Reference Fuel Reading Sequence

HANDWHEEL BRACKETING PROCEDURE



$$\begin{aligned}
 CN_S &= CN_{LRF} + \left(\frac{HW_S - HW_{LRF}}{HW_{HRF} - HW_{LRF}} \right) (CN_{HRF} - CN_{LRF}) \\
 &= 37.0 + \left(\frac{1.545 - 1.520}{1.576 - 1.520} \right) (42.3 - 37.0) \\
 &= 37.0 + (0.446)(5.3) = 39.4
 \end{aligned}$$

FIG. 4 Example of Cetane Number Calculations

14. Report

- 14.1 Report the calculated result as cetane number.
- 14.2 If the sample was filtered before testing, include this information in the report.

15. Precision and Bias

15.1 *Handwheel Bracketing Procedure Precision*—The precision of this test method and procedure based on statistical examination of interlaboratory test results is as follows:

15.1.1 *Repeatability*—The difference between two test results, obtained on identical test samples under repeatability conditions would, in the long run, in the normal and correct operation of the test method, exceed the values in Table 2 only in 1 case in 20.

15.1.2 *Reproducibility*—The difference between two single and independent results obtained on identical test samples under reproducibility conditions would, in the long run, in the normal and correct operation of the test method, exceed the values in Table 2 only in 1 case in 20.

15.1.3 *Repeatability precision limits* are based on the ASTM National Exchange Group (NEG) monthly sample

TABLE 2 Cetane Number Repeatability and Reproducibility Limits

Average Cetane Number Level ^A	Repeatability Limits, Cetane Number	Reproducibility Limits Cetane Number
40	0.8	2.8
44	0.9	3.3
48	0.9	3.8
52	0.9	4.3
56	1.0	4.8

^A Values for cetane numbers intermediate to those listed above, may be obtained by linear interpolation.

testing program data from mid-1978 through 1987. During this period each exchange sample was rated twice on the same day by the same operator on one engine in each of the Member laboratories.¹⁴

15.1.4 *Reproducibility precision limits* are based on the combined NEG monthly sample testing program data from mid-1978 through mid-1992, the Institute of Petroleum monthly sample data for 1988 through mid-1992 and the Institut Francais du Petrole monthly sample data for 1989 through early 1992.

15.1.5 The combination of the large number of sample sets and the fact that each sample is tested by 12 to 25 laboratories provides a comprehensive picture of the precision achievable using this test method. Analyzed graphically, the respective sample standard deviations were plotted vs cetane number. The variation in precision with respect to cetane number level for these data is best expressed by a linear regression of the values. The average standard deviation for each cetane number level has been multiplied by 2.772 to obtain the respective limit values.

15.2 *Bias*—The procedure in this test method for cetane number of diesel fuel oil has no bias because the value of cetane number can be defined only in terms of the test method.

16. Keywords

- 16.1 cetane number; diesel performance; ignition delay

¹⁴ Supporting data (a listing of the data and the analyses used to establish the precision statements) have been filed at ASTM International Headquarters and may be obtained by requesting Research Report RR: D02-1303.

ANNEXES

(Mandatory Information)

A1. WARNING INFORMATION

A1.1 Introduction

A1.1.1 In the performance of the standard test method there are hazards to personnel. These are indicated in the text. For more detailed information regarding the hazards, refer to the appropriate Material Safety Data Sheet (MSDS) for each of the applicable substances to establish risks, proper handling, and safety precautions.

A1.2 Warning

- A1.2.1 Combustible. Vapor harmful.
- A1.2.2 *Applicable Substances*:
 - A1.2.2.1 Diesel fuel oil.
 - A1.2.2.2 Reference material.
 - A1.2.2.3 Reference fuel.
 - A1.2.2.4 *n*-cetane.

- A1.2.2.5 Heptamethylnonane.
- A1.2.2.6 Alpha-methylnaphthalene.
- A1.2.2.7 Secondary reference fuels, *T Fuel* and *U Fuel*
- A1.2.2.8 Check Fuel.
- A1.2.2.9 Kerosine.
- A1.2.2.10 Warmup fuel.
- A1.2.2.11 Engine crankcase lubricating oil.

A1.3 Warning

A1.3.1 Flammable. Vapors harmful if inhaled. Vapors may cause flash fire.

A1.3.2 *Applicable Substances:*

- A1.3.2.1 Petroleum based solvent.

A1.4 Warning

A1.4.1 Poison. May be harmful or fatal if inhaled or swallowed.

A1.4.2 *Applicable Substances:*

- A1.4.2.1 Ethylene glycol based antifreeze

A2. ENGINE EQUIPMENT DESCRIPTION AND SPECIFICATIONS

A2.1 Engine Equipment

A2.1.1 The single cylinder cetane test engine is manufactured as a complete unit by Waukesha Engine Division, Dresser Industries, Inc. and consists of both critical and non-critical equipment. The Waukesha Engine Division designation is Model CFR F-5 Cetane Method Diesel Fuel Rating Unit. Waukesha Engine Division Part Numbers or References are included in parenthesis after the items where applicable.

A2.1.1.1 See Table A2.1.

A2.2 **Critical Equipment**—Critical engine components and primary assemblies which shall be used for this test method are listed. The bearings, gears, seals, covers, special fittings or hardware and gaskets manufactured by Waukesha Engine Division and applicable to each critical assembly shall also be considered critical.

A2.2.1 *Crankcase Assembly*—Model CFR-48 (109520D) specified to include the following major items (See Fig. A2.1):

- A2.2.1.1 Crankshaft Assembly (A109511H).
- A2.2.1.2 Piston Assembly (0023204B).
- A2.2.1.3 Rings, Piston, Compression, Straight (106222A), 4 required.

NOTE A2.1—Ring, Piston, Compression, Straight, Chrome (106222B), Use of a chrome ring in the top groove is optional with 3 compression rings (106222A) in the other 3 compression ring grooves.

- A2.2.1.4 Ring, Piston, Oil (23505).
- A2.2.1.5 Connecting Rod Assembly (BA111666).
- A2.2.1.6 Camshaft (109583B).
- A2.2.1.7 Balancing Shaft, 2 required (109510A).
- A2.2.1.8 Counterweight for Balancing Shaft, (109565) 2 required.
- A2.2.1.9 Flywheel (109501H) (applicable for 50 or 60 Hz units).
- A2.2.1.10 Oil Pump Assembly (110150A).
- A2.2.1.11 Oil Suction Screen Assembly (0109552).
- A2.2.1.12 Oil Pressure Control Valve Assembly (A109538A).
- A2.2.1.13 Crankcase Breather Assembly (Group 070.00).
- A2.2.1.14 Accessory Bracket, Fuel Pump (109515A).
- A2.2.1.15 Stud Assembly, Crankcase to Cylinder (B839.4 required: B5764.2 required).
- A2.2.1.16 Stud Nuts, Cylinder (105361, 6 required).

A2.2.2 *Cylinder Assembly*—(0105081) of cast iron with internal coolant passages and a basic bore diameter of 3.250 in., specified to include the following (See Fig. A2.2):

- A2.2.2.1 Stud Assembly, Cylinder to Head (B-8200, 5 required).
- A2.2.2.2 Stud Nuts, Cylinder Head (105361, 7 required).
- A2.2.2.3 Crankcase to Cylinder Spacer Gasket Set—Selection of one or more gaskets must be made at the time of cylinder assembly to achieve the specified piston over travel. Available gaskets are:

- Gasket, Cylinder Base—0.021 in. thick (105181)
- Gasket, Cylinder Base—0.015 in. thick (105181A)
- Gasket, Cylinder Base—0.010 in. thick (105181B)
- Gasket, Cylinder Base—0.003 in. thick (105181C)

A2.2.3 *Cylinder Head Assembly*—(AF105082B) of cast iron with internal coolant passages, a flat-top combustion chamber surface, a horizontal and cylindrical precombustion chamber to accept a matched and pinned, variable compression ratio handwheel housing on one end and including a passage

TABLE A2.1 General Engine Characteristics and Information

Item	Description
Crankcase	Model CFR-48 (Preferred), High or Low Speed Models (Optional)
Cylinder Type	Single bore cast iron with integral coolant jacket
Cylinder Head Type	Cast Iron with turbulence precombustion chamber, variable compression plug passage, integral coolant passages, and in-head valve assembly
Compression Ratio	Adjustable 8:1 to 36:1 by external handwheel assembly
Cylinder Bore (Diameter), in.	3.250 (Standard), Reboring to 0.010, 0.020, 0.030 over is acceptable
Stroke, in.	4.50
Displacement, cu in	37.33
Valve Mechanism	In-head with enclosure
Intake and Exhaust Valves	Stellite faced, plain type without shroud
Piston	Cast iron, flat top
Piston Rings:	
Compression Type	4, Ferrous, straight sided (Top may be chrome plated—Optional)
Oil Control	1, Cast iron, one piece, slotted (Type 85)
Camshaft Over lap, degree	5
Fuel System	Injection pump with variable timing device and injector
Injector	Holder with by-pass pressure release valve
Spray Nozzle	Closed, differential-needle, hydraulically-operated, pintle type
Weight of Engine	Approximately 400 kg (880 lb)
Weight of Complete Test Unit	Approximately 1250 kg (2750 lb)

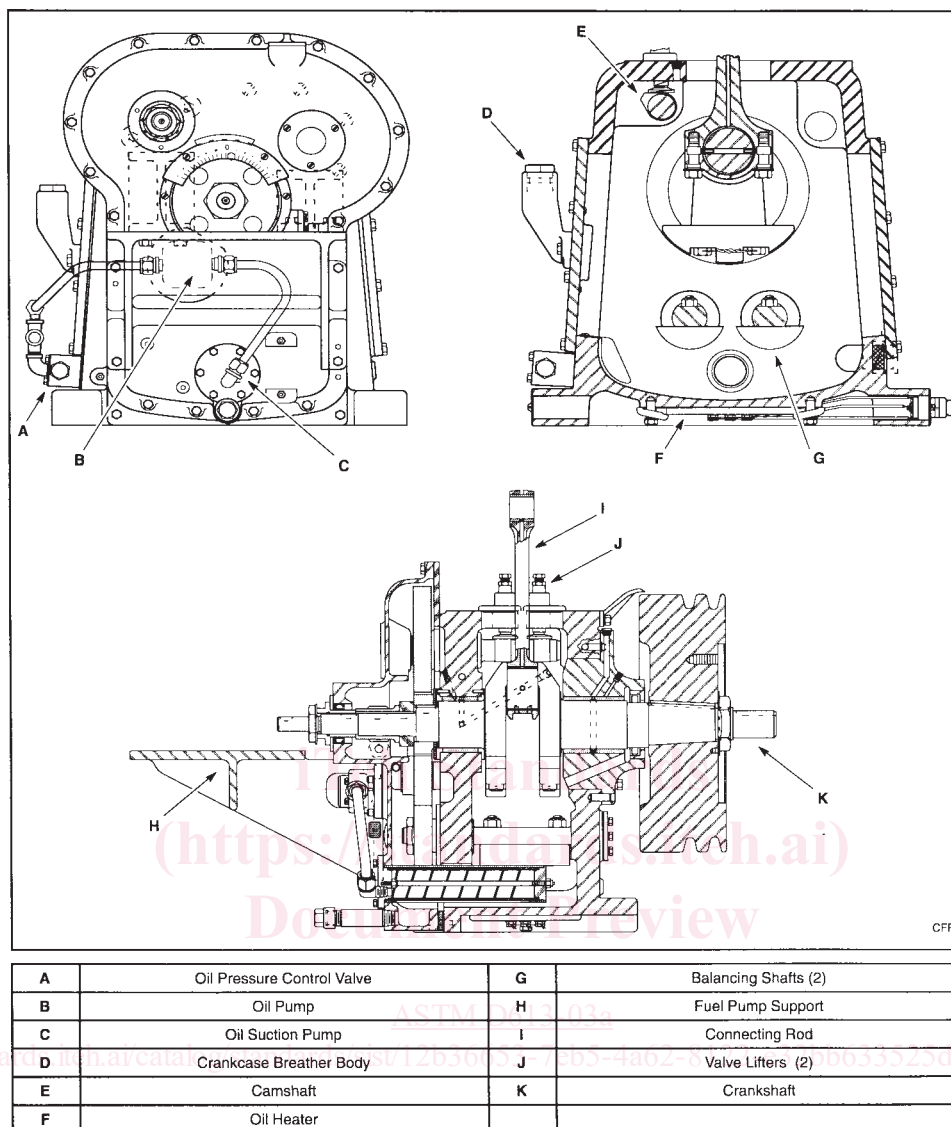

FIG. A2.1 CFR-48 Crankcase—Sectional Views

for insertion of an injector assembly at the other end. An angled passage, 0.5 in. square in cross-section, connects the precombustion chamber to the main combustion chamber. The assembly is specified to include the following major items (See Fig. A2.2 and Fig. A2.3):

A2.2.3.1 Integral but replaceable, hardened, Valve Seat Inserts (105987A),

A2.2.3.2 Integral but replaceable Valve Guides (23109A),

A2.2.3.3 Intake and Exhaust Valve (106625),

A2.2.3.4 Valve Spring, Rotator Assembly (G-806-3) including spring (109659), spacer (110200), felt (B4680), rotator (110165B) and tapers (109658),

A2.2.3.5 Valve Rocker Arm Subassembly (Group G-002.10).

A2.2.4 *Handwheel*—Variable Compression Plug Assembly—(A105097) including an expandable plug that is screwed in or out of the handwheel housing, an adjusting handwheel, a micrometer scale and barrel vernier to indicate plug position, and a locking wheel to cause a dished, split-

washer to flatten and expand the variable compression plug to seal the precombustion chamber. See Fig. A2.3.

A2.2.5 *Cylinder Coolant System Assembly*, specified to include the following major items.

A2.2.5.1 Condenser Body Assembly (A109264A) including condenser coil subassembly, baffle tube and sight glass subassembly.

A2.2.5.2 Condenser Water Pipe Assembly (0109131B).

A2.2.5.3 Water Inlet Pipe (105083).

A2.2.6 *Inlet Air System Assembly* (Group G-841-9) specified to include the following major items:

A2.2.6.1 Air Silencer Elbow (105188), with gaskets, nuts and washers.

A2.2.6.2 Air Heater Silencer Assembly (AA110468).

A2.2.6.3 Air Inlet Heater Assembly (A106583E).

A2.2.7 *Fuel System*—Components required to permit constant pressure introduction of sample or reference fuel blends to an injection pump, the injection pump with adjustment for flow rate, an integral variable timing device, a pump gallery air