



Designation: C1374 – 03

Standard Test Method for Determination of Installed Thickness of Pneumatically Applied Loose-Fill Building Insulation¹

This standard is issued under the fixed designation C1374; the number immediately following the designation indicates the year of original adoption or, in the case of revision, the year of last revision. A number in parentheses indicates the year of last reapproval. A superscript epsilon (ϵ) indicates an editorial change since the last revision or reapproval.

1. Scope

1.1 This test method covers determination of the installed thickness of pneumatically applied loose-fill building insulations prior to settling by simulating an open attic with horizontal blown applications.

1.2 This test method is a laboratory procedure for use by manufacturers of loose-fill insulation for product design, label development, and quality control testing. The apparatus used produces installed thickness results at a given mass/unit area.

1.3 This test method is not the same as the design density procedures described in Test Methods C520 or Specifications C739 or C764.

1.4 The values stated in inch-pound units are to be regarded as the standard. The values given in parentheses are provided for information only.

1.5 *This standard does not purport to address all of the safety concerns, if any, associated with its use. It is the responsibility of the user of this standard to establish appropriate safety and health practices and determine the applicability of regulatory limitations prior to use.*

2. Referenced Documents

- 2.1 *ASTM Standards*:²
- C168 Terminology Relating to Thermal Insulation
 - C520 Test Methods for Density of Granular Loose Fill Insulations
 - C739 Specification for Cellulosic Fiber Loose-Fill Thermal Insulation
 - C764 Specification for Mineral Fiber Loose-Fill Thermal Insulation

¹ This test method is under the jurisdiction of ASTM Committee C16 on Thermal Insulation and is the direct responsibility of Subcommittee C16.32 on Mechanical Properties.

Current edition approved April 10, 2003. Published May 2003. Originally approved in 1997. Last previous edition approved in 1997 as C1374-97. DOI: 10.1520/C1374-03.

² For referenced ASTM standards, visit the ASTM website, www.astm.org, or contact ASTM Customer Service at service@astm.org. For *Annual Book of ASTM Standards* volume information, refer to the standard's Document Summary page on the ASTM website.

E691 Practice for Conducting an Interlaboratory Study to Determine the Precision of a Test Method

3. Terminology

3.1 *Definitions*—Unless otherwise stated, the definitions listed in Terminology C168 are applicable herein.

3.2 *Definitions of Terms Specific to This Standard*:

3.2.1 *installed thickness, n*—the average thickness, as measured immediately after application of blown insulation material when applied at a given mass/unit area.

4. Summary of Test Method

4.1 A standardized test chamber of 80 ft² (7.4 m²) is used as a receptacle to receive a calculated mass/unit area of pneumatically applied insulation.

4.2 The mass of insulation to be blown into the test chamber is calculated from the bag label information.

4.3 The mass of insulation prescribed in 4.2 is uniformly blown into the test chamber.

4.4 The thickness of the blown insulation is determined at 13 predetermined locations.

4.5 The thickness average of three tests is the installed thickness for the mass/unit area being tested.

5. Significance and Use

5.1 This test method was designed to give the manufacturer of loose-fill insulation products a way of determining what the initial installed thickness should be in a horizontal open attic for pneumatic applications.

5.2 The installed thickness value developed by this test method is intended to provide guidance to the installer in order to achieve a minimum mass/unit area for a given *R*-value.

5.3 For the purpose of product design, testing should be done at a variety of *R*-values. At least three *R*-values should be used: the lowest *R*-value on the product label, the highest *R*-value on the product label, and an *R*-value near the midpoint of the *R*-value range.

NOTE 1—For quality control purposes, testing may be done at one *R*-value of *R*-19 (h \times ft² \times °F/Btu) or higher.

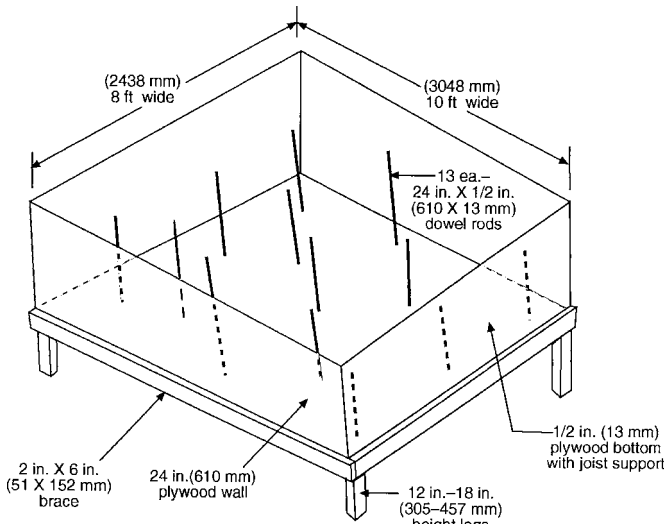

FIG. 1 Installed Thickness Test Chamber

5.4 Specimens are blown in a manner consistent with the intended installation procedure. Blowing machine settings should be representative of those typically used for field application with that machine.

5.5 The material blown for a given *R*-value as part of the installed thickness test equals the installed mass/unit area times the test chamber area. This mass can be calculated from information provided on the package label at the *R*-value prescribed.

6. Apparatus

6.1 *Blowing Machine*—A pneumatic blowing machine, designed primarily for handling loose-fill insulation materials, shall be used for blowing the insulation into the test chamber. This machine shall have throughput and material handling characteristics similar to that used in field applications.

6.2 *Blowing Hose*—The machine should utilize 150 ft (46 m) of 3-in. (76-mm) diameter flexible, corrugated blowing hose. At least 100 ft (30 m) of the hose should be elevated between 10 and 20 ft (3 and 6 m) above the blowing machine to simulate a typical installation configuration. The hose should have no more than eight 90° bends and no bends may be less than 4-ft (1.2-m) radius.

NOTE 2—It is good practice to clean the hose periodically by mechanically agitating it with the blower on. This practice should dislodge any pieces of insulation that might be caught in the hose.

6.3 *Test Specimen Chamber*—The specimen chamber shall be constructed in accordance with Fig. 1 with the reference dowels positioned as shown in Fig. 2.

NOTE 3—For some insulation materials it may be necessary to use a larger test chamber than shown to accommodate a more representative sample, when the test chamber size is changed, the precision may change.

6.4 *Weighing Devices*—A device is required to weigh the test material before loading into hopper. This device must determine the test material mass to within 0.5 %.

6.5 *Specimen Preparation Room*—An enclosed area where the test material is blown into the specimen chamber is required to protect the blowing operation from wind or strong

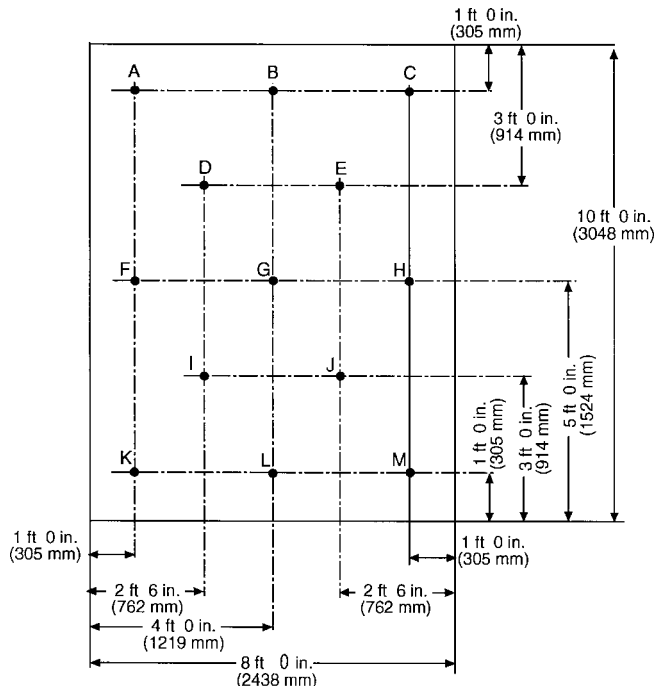

FIG. 2 Dowel Placement in Chamber Floor

air currents. Room geometry should not influence the blowing stream from the hose as long as there is adequate clearance around the sides to maneuver.

7. Sampling

7.1 Follow sampling plans given in the material specifications, regulations or other appropriate documents when applicable. In the absence of such directions, randomly select the number of bags of product required for testing to meet conditions in 8.2.

7.2 Condition the sample material by exposure in a conditioned space as prescribed by the contract or regulatory documents. If conditioning is not required, material must be in equilibrium with the storage environment.

8. Specimen Preparation

8.1 Clean the specimen chamber to be free of dirt and insulation prior to the start of the test.

NOTE 4—Many factors can influence the installation characteristics of blown insulation. These include blowing rate, machine adjustments, the size and length of the hose, and the angle and dimensions of the hose outlet in relation to the test chamber. Where available, use manufacturer’s instructions to establish machine settings.

8.2 From product label information, calculate the mass of insulation required to fill the test chamber for the *R*-value selected using the following formula:

$$W = A \times WSF \tag{1}$$

where:

- W* = total mass of material required lb (kg),
- A* = test chamber area, 80 ft² (7.4 m²), and
- WSF* = label mass/unit area lb/ft² (kg/m²).

8.3 Assemble the blowing machine, hose, and hose length combinations as appropriate for the material being prepared (see recommendations in Section 6).