



## Designation: D 305 – 84 (Reapproved 1999)

AMERICAN SOCIETY FOR TESTING AND MATERIALS  
100 Barr Harbor Dr., West Conshohocken, PA 19428  
Reprinted from the Annual Book of ASTM Standards. Copyright ASTM

# Standard Test Method for Solvent-Extractable Material in Black Pigments<sup>1</sup>

This standard is issued under the fixed designation D 305; the number immediately following the designation indicates the year of original adoption or, in the case of revision, the year of last revision. A number in parentheses indicates the year of last reapproval. A superscript epsilon ( $\epsilon$ ) indicates an editorial change since the last revision or reapproval.

## 1. Scope

1.1 This test method covers the determination of the solvent-extractable material in black pigments such as carbon black, lampblack, and bone black.

1.2 This standard does not purport to address all of the safety concerns, if any, associated with its use. It is the responsibility of the user of this standard to establish appropriate safety and health practices and determine the applicability of regulatory limitations prior to use.

## 2. Referenced Documents

- 2.1 ASTM Standards:  
D 329 Specification for Acetone<sup>2</sup>

## 3. Significance and Use

3.1 This test method is used by black pigment producers and users for product acceptance.

## 4. Apparatus

4.1 *Extraction Apparatus*, consisting of a flask, siphon cup, and a condenser similar to the apparatus shown in either Fig. 1 or Fig. 2.

NOTE 1—A Sophlet apparatus may be used as an alternative.

4.2 *Extraction Thimbles*—The thimble must be made of greaseless paper and be of correct size to fill the selected apparatus.

NOTE 2—The recommended thimble size for each of the apparatus shown in Fig. 1 is listed below:

	Fig. 1	Fig. 2
Height	70 mm	62 mm
Inside diameter	28 mm	22 mm
Outside diameter	30 mm	24 mm

4.3 The thimbles are available in various heights and widths with two thickness levels, single thickness or double thickness. Single-thickness thimbles are recommended for this extraction procedure.

## 5. Reagents and Material

5.1 *Purity of Reagents*—Reagent grade chemicals shall be

<sup>1</sup> This test method is under the jurisdiction of ASTM Committee D-1 on Paint and Related Coatings, Materials, and Applications and is the direct responsibility of Subcommittee D01.31 on Pigment Specifications.

Current edition approved Aug. 31, 1984. Published October 1984. Originally published as D 305 – 29 T. Last previous edition D 305 – 72 (1978).

<sup>2</sup> *Annual Book of ASTM Standards*, Vol 06.04.

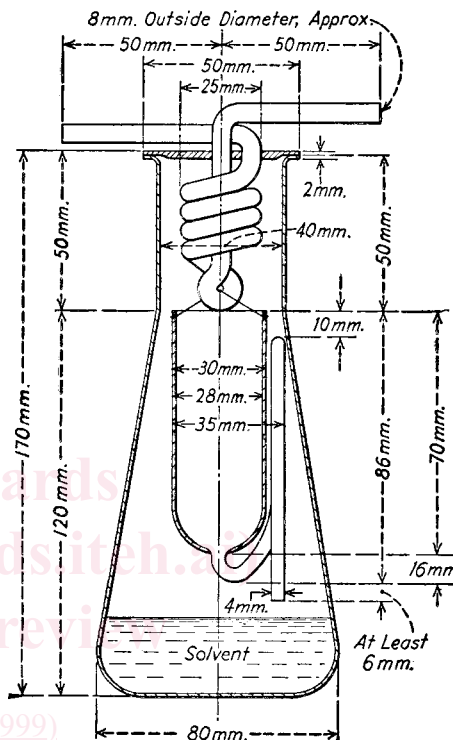

FIG. 1 Extraction Apparatus

used in all tests. Unless otherwise indicated, it is intended that all reagents shall conform to the specifications of the Committee on Analytical Reagents of the American Chemical Society, where such specifications are available.<sup>3</sup> Other grades may be used, provided it is first ascertained that the reagent is of sufficiently high purity to permit its use without lessening the accuracy of the determination.

5.2 *Solvent*—Acetone and benzene are the most commonly used solvents (see Specification D 329); however, other solvents may be used as agreed upon.

5.3 *Glass Wool*.

## 6. Procedure

6.1 Weight approximately 10 g of pigment (moisture-free)

<sup>3</sup> *Reagent Chemicals, American Chemical Society Specifications*, American Chemical Society, Washington, DC. For suggestions on the testing of reagents not listed by the American Chemical Society, see *Analar Standards for Laboratory Chemicals*, BDH Ltd., Poole, Dorset, U.K., and the *United States Pharmacopoeia and National Formulary*, U.S. Pharmacopoeial Convention, Inc. (USPC), Rockville, MD.