

ITh STANDARD PREVIEW
(standards.iteh.ai)

petroleum and natural gas industries - Design and operation of subsea production systems - Part 10: Specification for bonded flexible pipe (ISO 13628-10:2006)

Petroleum and natural gas industries - Design and operation of subsea production systems - Part 10: Specification for bonded flexible pipe (ISO 13628-10:2006)

Erdöl- und Erdgasgewinnung - Konstruktion und Betrieb von Unterwasser-Produktionssystemen - Teil 10: Anforderungen an miteinander verklebte Leitungen (ISO 13628-10:2006)

Industries du pétrole et du gaz naturel - Conception et exploitation des systèmes de production immergés - Partie 10: Spécification pour canalisations flexibles composites (ISO 13628-10:2006)

Ta slovenski standard je istoveten z: EN ISO 13628-10:2006

ICS:

75.180.10	Oprema za raziskovanje in odkopavanje	Exploratory and extraction equipment
-----------	---------------------------------------	--------------------------------------

SIST EN ISO 13628-10:2007**en**

iTeh STANDARD PREVIEW
(standards.iteh.ai)

SIST EN ISO 13628-10:2007

<https://standards.iteh.ai/catalog/standards/sist/2a720f70-7707-45ea-b452-cd038384b980/sist-en-iso-13628-10-2007>

ICS 75.180.10

English Version

Petroleum and natural gas industries - Design and operation of
subsea production systems - Part 10: Specification for bonded
flexible pipe (ISO 13628-10:2005)

Industries du pétrole et du gaz naturel - Conception et
exploitation des systèmes de production immergés - Partie
10: Spécification pour canalisations flexibles composites
(ISO 13628-10:2005)

Erdöl- und Erdgasgewinnung - Konstruktion und Betrieb
von Unterwasser-Produktionssystemen - Teil 10:
Anforderungen an miteinander verklebte Leitungen (ISO
13628-10:2005)

This European Standard was approved by CEN on 6 October 2006.

CEN members are bound to comply with the CEN/CENELEC Internal Regulations which stipulate the conditions for giving this European Standard the status of a national standard without any alteration. Up-to-date lists and bibliographical references concerning such national standards may be obtained on application to the Central Secretariat or to any CEN member.

This European Standard exists in three official versions (English, French, German). A version in any other language made by translation under the responsibility of a CEN member into its own language and notified to the Central Secretariat has the same status as the official versions.

CEN members are the national standards bodies of Austria, Belgium, Cyprus, Czech Republic, Denmark, Estonia, Finland, France, Germany, Greece, Hungary, Iceland, Ireland, Italy, Latvia, Lithuania, Luxembourg, Malta, Netherlands, Norway, Poland, Portugal, Romania, Slovakia, Slovenia, Spain, Sweden, Switzerland and United Kingdom.



EUROPEAN COMMITTEE FOR STANDARDIZATION
COMITÉ EUROPÉEN DE NORMALISATION
EUROPÄISCHES KOMITEE FÜR NORMUNG

Management Centre: rue de Stassart, 36 B-1050 Brussels

Foreword

The text of ISO 13628-10:2005 has been prepared by Technical Committee ISO/TC 67 "Materials, equipment and offshore structures for petroleum and natural gas industries" of the International Organization for Standardization (ISO) and has been taken over as EN ISO 13628-10:2006 by Technical Committee CEN/TC 12 "Materials, equipment and offshore structures for petroleum, petrochemical and natural gas industries", the secretariat of which is held by AFNOR.

This European Standard shall be given the status of a national standard, either by publication of an identical text or by endorsement, at the latest by April 2007, and conflicting national standards shall be withdrawn at the latest by April 2007.

According to the CEN/CENELEC Internal Regulations, the national standards organizations of the following countries are bound to implement this European Standard: Austria, Belgium, Cyprus, Czech Republic, Denmark, Estonia, Finland, France, Germany, Greece, Hungary, Iceland, Ireland, Italy, Latvia, Lithuania, Luxembourg, Malta, Netherlands, Norway, Poland, Portugal, Romania, Slovakia, Slovenia, Spain, Sweden, Switzerland and United Kingdom.

Endorsement notice

The text of ISO 13628-10:2005 has been approved by CEN as EN ISO 13628-10:2006 without any modifications.

iTeh STANDARD PREVIEW
(standards.iteh.ai)

SIST EN ISO 13628-10:2007
<https://standards.iteh.ai/catalog/standards/sist/2a720f70-7707-45ea-b452-cd038384b980/sist-en-iso-13628-10-2007>

**Petroleum and natural gas industries —
Design and operation of subsea
production systems —**

**Part 10:
Specification for bonded flexible pipe**

iTeh STANDARD PREVIEW
(standards.iteh.ai)

*Industries du pétrole et du gaz naturel — Conception et exploitation des
systèmes de production immergés —*

Partie 10: Spécification pour canalisations flexibles composites

SIST EN ISO 13628-10:2007

<https://standards.iteh.ai/catalog/standards/sist/2a720f70-7707-45ea-b452-cd038384b980/sist-en-iso-13628-10-2007>



PDF disclaimer

This PDF file may contain embedded typefaces. In accordance with Adobe's licensing policy, this file may be printed or viewed but shall not be edited unless the typefaces which are embedded are licensed to and installed on the computer performing the editing. In downloading this file, parties accept therein the responsibility of not infringing Adobe's licensing policy. The ISO Central Secretariat accepts no liability in this area.

Adobe is a trademark of Adobe Systems Incorporated.

Details of the software products used to create this PDF file can be found in the General Info relative to the file; the PDF-creation parameters were optimized for printing. Every care has been taken to ensure that the file is suitable for use by ISO member bodies. In the unlikely event that a problem relating to it is found, please inform the Central Secretariat at the address given below.

iTeh STANDARD PREVIEW
(standards.iteh.ai)

[SIST EN ISO 13628-10:2007](https://standards.iteh.ai/catalog/standards/sist/2a720f70-7707-45ea-b452-cd038384b980/sist-en-iso-13628-10-2007)

<https://standards.iteh.ai/catalog/standards/sist/2a720f70-7707-45ea-b452-cd038384b980/sist-en-iso-13628-10-2007>

© ISO 2005

All rights reserved. Unless otherwise specified, no part of this publication may be reproduced or utilized in any form or by any means, electronic or mechanical, including photocopying and microfilm, without permission in writing from either ISO at the address below or ISO's member body in the country of the requester.

ISO copyright office
Case postale 56 • CH-1211 Geneva 20
Tel. + 41 22 749 01 11
Fax + 41 22 749 09 47
E-mail copyright@iso.org
Web www.iso.org

Published in Switzerland

Contents

Page

Foreword.....	v
Introduction	vi
1 Scope	1
1.1 Purpose.....	1
1.2 Products	2
1.3 Applications	2
2 Normative references	2
3 Terms, definitions and abbreviations	5
3.1 Terms and definitions.....	5
3.2 Symbols and abbreviations	10
4 Functional requirements	11
4.1 General.....	11
4.2 Overall requirements	11
4.3 General design parameters	12
4.4 Internal fluid parameters	12
4.5 External environment	14
4.6 System requirements	14
5 Design requirements	17
5.1 Loads and load effects	17
5.2 Pipe design methodology	20
5.3 Pipe structure design	21
5.4 System design requirements	26
6 Materials	29
6.1 Material requirements.....	29
6.2 Qualification requirements	33
6.3 Quality assurance requirements	39
7 Manufacturing requirements	41
7.1 Quality assurance requirements	41
7.2 Carcass	42
7.3 Preparation of compound and calendering	43
7.4 Elastomer winding	44
7.5 Reinforcement armour layer	45
7.6 Insulation layers.....	45
7.7 End fitting	45
7.8 Curing process.....	47
7.9 Special processes.....	48
7.10 Manufacturing tolerances	50
7.11 Repairs	50
8 Documentation	51
8.1 General.....	51
8.2 Design premise	51
8.3 Design load report	51
8.4 Design report.....	51
8.5 Manufacturing quality plan	52
8.6 Fabrication specification	52
8.7 As-built documentation.....	52
8.8 Operation manual	53

9	Factory acceptance tests	54
9.1	General	54
9.2	Gauge test	55
9.3	Hydrostatic pressure test	55
9.4	Electrical continuity and resistance tests	56
9.5	Kerosene test	56
9.6	Vacuum test	56
10	Marking and packaging	57
10.1	Marking	57
10.2	Packaging	57
Annex A	(informative) Purchasing guidelines	59
Annex B	(informative) Bend stiffeners and bend restrictors	66
Annex C	(informative) Use of the API Monogram	71
Bibliography	72

iTeh STANDARD PREVIEW
(standards.iteh.ai)

[SIST EN ISO 13628-10:2007](https://standards.iteh.ai/catalog/standards/sist/2a720f70-7707-45ea-b452-cd038384b980/sist-en-iso-13628-10-2007)
<https://standards.iteh.ai/catalog/standards/sist/2a720f70-7707-45ea-b452-cd038384b980/sist-en-iso-13628-10-2007>

Foreword

ISO (the International Organization for Standardization) is a worldwide federation of national standards bodies (ISO member bodies). The work of preparing International Standards is normally carried out through ISO technical committees. Each member body interested in a subject for which a technical committee has been established has the right to be represented on that committee. International organizations, governmental and non-governmental, in liaison with ISO, also take part in the work. ISO collaborates closely with the International Electrotechnical Commission (IEC) on all matters of electrotechnical standardization.

International Standards are drafted in accordance with the rules given in the ISO/IEC Directives, Part 2.

The main task of technical committees is to prepare International Standards. Draft International Standards adopted by the technical committees are circulated to the member bodies for voting. Publication as an International Standard requires approval by at least 75 % of the member bodies casting a vote.

Attention is drawn to the possibility that some of the elements of this document may be the subject of patent rights. ISO shall not be held responsible for identifying any or all such patent rights.

ISO 13628-10 was prepared by Technical Committee ISO/TC 67, *Materials, equipment and offshore structures for petroleum, petrochemical and natural gas industries*, Subcommittee SC 4, *Drilling and production equipment*.

ISO 13628 consists of the following parts under the general title *Petroleum and natural gas industries — Design and operation of subsea production systems*:

- *Part 1: General requirements and recommendations*
- *Part 2: Unbonded flexible pipe systems for subsea and marine applications*
- *Part 3: Through flowline (TFL) systems*
- *Part 4: Subsea wellhead and tree equipment*
- *Part 5: Subsea umbilicals*
- *Part 6: Subsea production control systems*
- *Part 7: Completion/workover riser systems*
- *Part 8: Remotely Operated Vehicle (ROV) interfaces on subsea production systems*
- *Part 9: Remotely Operated Tool (ROT) intervention system*
- *Part 10: Specification for bonded flexible pipe*
- *Part 11: Flexible pipe systems for subsea and marine riser applications*

The following part is under preparation:

- *Part 12: Dynamic production risers*

Introduction

This part of ISO 13628 has been based on API Spec 17K, First Edition, September 2001.

Users of this International Standard should be aware that further or differing requirements might be needed for individual applications. This International Standard is not intended to inhibit a vendor from offering, or the purchaser from accepting, alternative equipment or engineering solutions for the individual application. This may be particularly applicable where there is innovative or developing technology. Where an alternative is offered, the vendor should identify any variations from this International Standard and provide details.

iTeh STANDARD PREVIEW (standards.iteh.ai)

SIST EN ISO 13628-10:2007

<https://standards.iteh.ai/catalog/standards/sist/2a720f70-7707-45ea-b452-cd038384b980/sist-en-iso-13628-10-2007>

Petroleum and natural gas industries — Design and operation of subsea production systems —

Part 10: Specification for bonded flexible pipe

1 Scope

1.1 Purpose

1.1.1 This part of ISO 13628 defines the technical requirements for safe, dimensionally and functionally interchangeable bonded flexible pipes that are designed and manufactured to uniform standards and criteria. See Figure 1 for explanatory figure on typical bonded flexible pipe.

1.1.2 Minimum requirements are specified for the design, material selection, manufacture, testing, marking and packaging of bonded flexible pipes, with reference to existing codes and standards where applicable. See API RP 17B for guidelines on the use of flexible pipes and ancillary components.

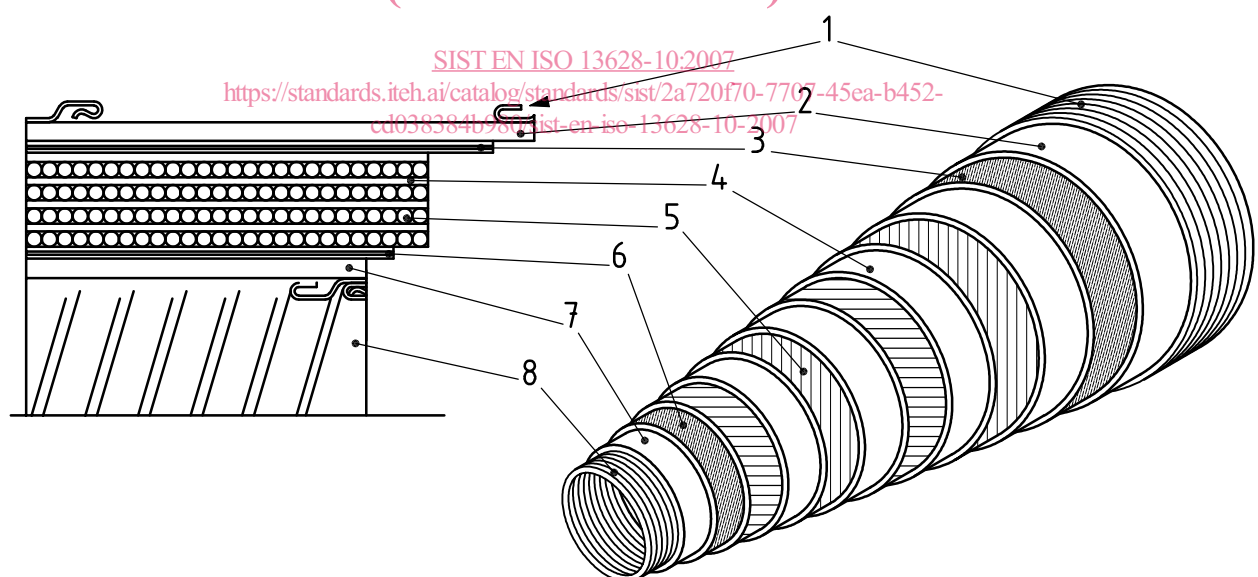

Key

- | | | | |
|---|---------------|---|---------------------|
| 1 | outer wrap | 5 | reinforcement layer |
| 2 | cover | 6 | breaker layer |
| 3 | breaker layer | 7 | liner |
| 4 | cushion layer | 8 | carcass |

Figure 1 — Typical bonded flexible pipe

1.2 Products

1.2.1 This part of ISO 13628 applies to bonded flexible pipe assemblies, consisting of segments of flexible pipe body with end fittings attached to both ends. This part of ISO 13628 does not cover flexible pipes of unbonded structure. See ISO 13628-2 for guidance on unbonded flexible pipes.

NOTE For the purposes of this provision, API Spec 17J^[10] is equivalent to ISO 13628-2.

1.2.2 This part of ISO 13628 does not apply to flexible pipe ancillary components. Guidelines for ancillary components are given in API RP 17B.

1.2.3 This part of ISO 13628 can be applied to flexible pipes that include non-metallic reinforcing layers, though no effort was made to address the specific and unique technological aspects of this product.

1.2.4 This part of ISO 13628 can be applied to a bonded construction pipe that includes a material or layer construction that is covered in ISO 13628-2.

NOTE For the purposes of this provision, API Spec 17J^[10] is equivalent to ISO 13628-2.

1.3 Applications

1.3.1 The applications addressed by this part of ISO 13628 are sweet and sour service production, including export and injection applications. Production products include oil, gas, water and injection chemicals. This part of ISO 13628 applies to both static and dynamic flexible pipes used as flowlines, risers, jumpers and offshore loading and discharge hoses. This part of ISO 13628 applies to pipes with a design pressure greater than or equal to 1,5 MPa (15 bar). This part of ISO 13628 can be used for lower design pressure pipes, though the requirements of these pipes have not been specifically addressed. Reference OCIMF^[30] for guidelines on these pipes.

1.3.2 This part of ISO 13628 does not apply to flexible pipes for use in choke and kill line applications. See API Spec 16C for guidance on choke and kill line applications. This part of ISO 13628 can be applied to flexible pipes for pile hammer, gas flare, water supply and jetting applications, though no effort was made to address the specific and unique technological aspects relating to each of these requirements.

2 Normative references

The following referenced documents are indispensable for the application of this document. For dated references, only the edition cited applies. For undated references, the latest edition of the referenced document (including any amendments) applies.

ISO 34-2, *Rubber, vulcanized or thermoplastic — Determination of tear strength — Part 2: Small (Delft) test pieces*

ISO 37, *Rubber, vulcanized or thermoplastic — Determination of tensile stress-strain properties*

ISO 75 (all parts), *Plastics — Determination of temperature of deflection under load*

ISO 812, *Rubber, vulcanized — Determination of low-temperature brittleness*

ISO 868, *Plastics and ebonite — Determination of indentation hardness by means of a durometer (Shore hardness)*

ISO 1431-1:2004, *Rubber, vulcanized or thermoplastic — Resistance to ozone cracking — Part 1: Static and dynamic strain testing*

ISO 1817, *Rubber, vulcanized — Determination of the effect of liquids*

ISO 2781, *Rubber, vulcanized — Determination of density*

ISO 4647:1982, *Rubber, vulcanized — Determination of static adhesion to textile cord — H-pull test*

ISO 4649, *Rubber, vulcanized or thermoplastic — Determination of abrasion resistance using a rotating cylindrical drum device*

ISO 6506-1, *Metallic materials — Brinell hardness test — Part 1: Test method*

ISO 6508-1, *Metallic materials — Rockwell hardness test — Part 1: Test method (scales A, B, C, D, E, F, G, H, K, N, T)*

ISO 6892, *Metallic materials — Tensile testing at ambient temperature*

ISO 10423, *Petroleum and natural gas industries — Drilling and production equipment — Wellhead and christmas tree equipment*

ISO 10474, *Steel and steel products — Inspection documents*

ISO 13628-4, *Petroleum and natural gas industries — Design and operation of subsea production systems — Part 4: Subsea wellhead and tree equipment*

ISO 13665, *Seamless and welded steel tubes for pressure purposes — Magnetic particle inspection of the tube body for the detection of surface imperfections*

ISO 15156 (all parts), *Petroleum and natural gas industries — Materials for use in H₂S-containing environments in oil and gas production*

ISO 16120-1, *Non-alloy steel wire rod for conversion to wire — Part 1: General requirements*

API RP 17B, *Recommended Practice for Flexible Pipe*

API¹⁾ Standard 1104, *Welding of Pipelines and Related Facilities*

ASME²⁾ Section IX, Boiler & Pressure Vessel Code, *Welding and Brazing Qualifications*

ASTM³⁾ A29/A29M:2005, *Standard Specification for Steel Bars, Carbon and Alloy, Hot-Wrought — General Requirements for*

ASTM A182/A182M:2005, *Standard Specification for Forged or Rolled Alloy-Steel Pipe Flanges, Forged Fittings, and Valves and Parts for High Temperature Service*

ASTM A388, *Standard Practice for Ultrasonic Examination of Heavy Steel Forgings*

ASTM A668/A668M:2004, *Standard Specification for Steel Forgings, Carbon and Alloy, for General Industrial Use*

ASTM A751, *Standard Test Methods, Practices, and Terminology for Chemical Analysis of Steel Products*

ASTM C177, *Standard Test Method for Steady-State Heat Flux Measurements and Thermal Transmission Properties by Means of the Guarded-Hot-Plate Apparatus*

1) American Petroleum Institute, 1220 L St NW, Washington DC 20005, USA.

2) American Society of Mechanical Engineers.

3) American Society for Testing and Materials.

ISO 13628-10:2005(E)

ASTM D256, *Standard Test Methods for Determining the Izod Pendulum Impact Resistance of Plastics*

ASTM D395, *Standard Test Methods for Rubber Property — Compression Set*

ASTM D412, *Standard Test Methods for Vulcanized Rubber and Thermoplastic Rubbers and Thermoplastic Elastomers — Tension*

ASTM D413, *Standard Test Methods for Rubber Property — Adhesion to Flexible Substrate*

ASTM D570, *Standard Test Method for Water Absorption of Plastics*

ASTM D664, *Standard Test Method for Acid Number of Petroleum Products by Potentiometric Titration*

ASTM D695, *Standard Test Method for Compressive Properties of Rigid Plastics*

ASTM D746, *Standard Test Method for Brittleness Temperature of Plastics and Elastomers by Impact*

ASTM D974, *Standard Test Method for Acid and Base Number by Color-Indicator Titration*

ASTM D1418, *Standard Practice for Rubber and Rubber Lattices — Nomenclature*

ASTM D2084, *Standard Test Method for Rubber Property — Vulcanization Using Oscillating Disk Cure Meter*

ASTM D2583, *Standard Test Method for Indentation Hardness of Rigid Plastics by Means of a Barcol Impressor*

ASTM D5028, *Standard Test Method for Curing Properties of Pultrusion Resins by Thermal Analysis*

ASTM E92, *Standard Test Method for Vickers Hardness of Metallic Materials*

ASTM E94, *Standard Guide for Radiographic Examination*

ASTM E165, *Standard Test method for Liquid Penetrant Examination*

ASTM E328, *Standard Test Methods for Stress Relaxation Tests for Materials and Structures*

ASTM E428, *Standard Practice for Fabrication and Control of Steel Reference Blocks Used in Ultrasonic Examination*

ASTM E1356, *Standard Test Method for Assignment of the Glass Transition Temperatures by Differential Scanning Calorimetry*

ASTM G48, *Standard Test Method for Pitting and Crevice Corrosion Resistance of Stainless Steels and Related Alloys by Use of Ferric Chloride Solution*

ISO 36, *Rubber, vulcanized or thermoplastic — Determination of adhesion to textile fabrics*

DNV⁴⁾ Fire Test, *DNV Classification Note 6.1 Test (Fire Test)*

DIN⁵⁾ 53505, *Shore A and Shore D hardness testing of rubber*

DIN 53516, *Testing of rubber and elastomers; determination of abrasion resistance*

EN⁶⁾ 287-1, *Qualification test of welders — Fusion welding — Part 1: Steels*

4) Det Norske Veritase.

5) Deutsches Institut für Normung e.V.

6) European Committee for Standardization.

EN 288-1, *Specification and approval of welding procedures for metallic materials — Part 1: General rules for fusion welding*

EN 288-2, *Specification and approval of welding procedures for metallic materials — Part 2: Welding procedure specification for arc welding*

EN 288-3, *Specification and approval of welding procedures for metallic materials — Part 3: Welding procedure tests for the arc welding of steels*

EN 10204, *Metallic products — Types of inspection documents*

Lloyds Fire Test, *Lloyds Register of Shipping, Fire Testing Memorandum ICE/Fire OSG 1000/499*

NACE TM0177, *Laboratory Testing of Metals for Resistance to Sulfide Stress Cracking and Stress Corrosion Cracking in H₂S Environments*

3 Terms, definitions and abbreviations

3.1 Terms and definitions

For the purposes of this document, the following terms and definitions apply.

3.1.1

ancillary components

components used to control the flexible pipe behaviour, such as buoyancy aids and fire hoods/boxes

3.1.2

API Monogram

registered mark of the American Petroleum Institute

3.1.3

bellmouth

part of a guide tube, formed in the shape of a bellmouth, and designed to prevent overbending of the flexible pipe

3.1.4

bend limiter

any device used to restrict bending of the flexible pipe

NOTE

Bend limiters include bend restrictors, bend stiffeners and bellmouths.

3.1.5

bend radius

radius of curvature of the flexible pipe measured from the pipe centreline

NOTE

Storage and operating minimum bend radii are defined in 5.3.1.6 and 5.3.1.7.

3.1.6

bend restrictor

mechanical device that functions as a mechanical stop and limits the local radius of curvature of the flexible pipe to a minimum value

3.1.7

bend stiffener

ancillary conically shaped component, which locally supports the pipe to limit bending stresses and curvature of the pipe to acceptable levels

NOTE

Bend stiffeners can be either attached to an end fitting or a support structure where the flexible pipe passes through the bend stiffener.