



# Standard Specification for Castings, Steel and Alloy, Common Requirements, for General Industrial Use<sup>1</sup>

This standard is issued under the fixed designation A 781/A 781M; the number immediately following the designation indicates the year of original adoption or, in the case of revision, the year of last revision. A number in parentheses indicates the year of last reapproval. A superscript epsilon ( $\epsilon$ ) indicates an editorial change since the last revision or reapproval.

## 1. Scope

1.1 This specification covers a group of requirements that are mandatory requirements of the following steel casting specifications issued by ASTM. If the product specification specifies different requirements, the product specification shall prevail.

ASTM Designation	Title of Specification
A 27/A 27M	Steel Castings, Carbon, for General Application
A 128/A 128M	Steel Castings, Austenitic Manganese
A 148/A 148M	Steel Castings, High-Strength, for Structural Purposes
A 297/A 297M	Steel Castings, Iron Chromium and Iron-Chromium-Nickel, Heat Resistant for General Application
A 447/A 447M	Steel Castings, Chromium-Nickel-Iron Alloy (25-12 Class), for High-Temperature Service
A 486/A 486M	Steel Castings, for Highway Bridges
A 494/A 494M	Castings, Nickel and Nickel Alloy
A 560/A 560M	Castings, Chromium-Nickel Alloy
A 743/A 743M	Castings, Iron-Chromium, Iron-Chromium-Nickel, Corrosion Resistant, for General Application
A 744/A 744M	Castings, Iron-Chromium-Nickel, Corrosion Resistant, for Severe Service
A 747/A 747M	Steel Castings, Stainless, Precipitation Hardening
A 890/A 890M	Castings, Iron-Chromium-Nickel-Molybdenum Corrosion-Resistant, Duplex (Austenitic/Ferritic) for General Application
A 915/A 915M	Steel Castings, Carbon and Alloy, Chemical Requirements Similar to Standard Wrought Grades
A 958	Steel Castings, Carbon and Alloy, with Tensile Requirements, Chemical Requirements Similar to Standard Wrought Grades
A 1002	Castings, Nickel-Aluminum Ordered Alloy

1.2 This specification also covers a group of supplementary requirements that may be applied to the above specifications as indicated therein. These are provided for use when additional testing or inspection is desired and apply only when specified individually by the purchaser in the order.

1.3 The requirements of the individual material specification, and this general specification shall prevail in the sequence named.

1.4 The values stated in either inch-pound units or SI units are to be regarded separately as standard. Within the text, the SI units are shown in brackets. The values stated in each

system are not exact equivalents; therefore, each system must be used independently of the other. Combining values from the two systems may result in nonconformance with the specification. Inch-pound units are applicable for material ordered to Specification A 781 and SI units for material ordered to Specification A 781M.

## 2. Referenced Documents

### 2.1 ASTM Standards:

- A 27/A27M Specification for Steel Castings, Carbon, for General Application<sup>2</sup>
- A 128/A128M Specification for Steel Castings, Austenitic Manganese<sup>2</sup>
- A 148/A148M Specification for Steel Castings, High Strength, for Structural Purposes<sup>2</sup>
- A 297/A297M Specification for Steel Castings, Iron-Chromium and Iron-Chromium-Nickel, Heat Resistant, for General Application<sup>2</sup>
- A 370 Test Methods and Definitions for Mechanical Testing of Steel Products<sup>3</sup>
- A 380 Practice for Cleaning, Descaling, and Passivation of Stainless Steel Parts, Equipment, and Systems<sup>3</sup>
- A 447/A 447M Specification for Steel Castings, Chromium-Nickel-Iron Alloy (25-12 Class), for High-Temperature Service<sup>2</sup>
- A 486/A 486M Specification for Steel Castings for Highway Bridges<sup>4</sup>
- A 488/A 488M Practice for Steel Castings, Welding, Qualifications of Procedures and Personnel<sup>2</sup>
- A 494/A 494M Specification for Castings, Nickel and Nickel Alloy<sup>2</sup>
- A 560/A 560M Specification for Castings, Chromium-Nickel Alloy<sup>2</sup>
- A 609/A 609M Practice for Castings, Carbon, Low-Alloy, and Martensitic Stainless Steel, Ultrasonic Examination Thereof<sup>2</sup>
- A 743/A 743M Specification for Castings, Iron-Chromium, Iron-Chromium-Nickel, Corrosion-Resistant, for General Application<sup>2</sup>

<sup>1</sup> This specification is under the jurisdiction of ASTM Committee A01 on Steel, Stainless Steel and Related Alloys and is the direct responsibility of Subcommittee A01.18 on Castings.

Current edition approved May 10, 2003. Published June 2003. Originally approved in 1980. Last previous edition approved in 2003 as A 781/A 781M – 03.

<sup>2</sup> Annual Book of ASTM Standards, Vol 01.02.

<sup>3</sup> Annual Book of ASTM Standards, Vol 01.03.

<sup>4</sup> Discontinued 1987. See 1986 Annual Book of ASTM Standards, Vol 01.02.



- A 744/A 744M Specification for Castings, Iron-Chromium-Nickel, Corrosion Resistant, for Severe Service<sup>2</sup>
- A 747/A 747M Specification for Steel Castings, Stainless, Precipitation Hardening<sup>2</sup>
- A 751 Test Methods, Practices, and Terminology for Chemical Analysis of Steel Products<sup>3</sup>
- A 800/A 800M Practice for Steel Castings, Austenitic Alloy, Estimating Ferrite Content Thereof<sup>2</sup>
- A 802/A 802M Practice for Steel Castings, Surface Acceptance Standards, Visual Examination<sup>2</sup>
- A 890/A 890M Specification for Castings, Iron-Chromium-Nickel-Molybdenum Corrosion-Resistant, Duplex (Austenitic/Ferritic) for General Application<sup>2</sup>
- A 915/A 915M Specification for Steel Castings, Carbon and Alloy, Chemical Requirements Similar to Standard Wrought Grades<sup>2</sup>
- A 941 Terminology Relating to Steel, Stainless Steel, Related Alloys, and Ferroalloys<sup>5</sup>
- A 958 Specification for Steel Castings, Carbon and Alloy, with Tensile Requirements, Chemical Requirements Similar to Standard Wrought Grades<sup>2</sup>
- A 967 Specification for Chemical Passivation Treatments for Stainless Steel Parts<sup>3</sup>
- A 991/A 991M Test Method for Conducting Temperature Uniformity Surveys of Furnaces Used to Heat Treat Steel Products<sup>3</sup>
- A 1002 Specification for Castings, Nickel-Aluminum Ordered Alloy<sup>2</sup>
- E 94 Guide for Radiographic Examination<sup>6</sup>
- E 125 Reference Photographs for Magnetic Particle Indications on Ferrous Castings<sup>6</sup>
- E 165 Test Method for Liquid Penetrant Examination<sup>6</sup>
- E 186 Reference Radiographs for Heavy-Walled (2 to 4½-in. (51 to 114-mm)) Steel Castings<sup>6</sup>
- E 280 Reference Radiographs for Heavy-Walled (4½ to 12-in. (114 to 305-mm)) Steel Castings<sup>6</sup>
- E 340 Test Method for Macroetching Metals and Alloys<sup>7</sup>
- E 353 Test Methods for Chemical Analysis of Stainless, Heat-Resisting, Maraging, and Other Similar Chromium-Nickel-Iron Alloys<sup>8</sup>
- E 354 Test Methods for Chemical Analysis of High-Temperature, Electrical, Magnetic, and Other Similar Iron, Nickel, and Cobalt Alloys<sup>8</sup>
- E 446 Reference Radiographs for Steel Castings Up to 2 in. (51 mm) in Thickness<sup>6</sup>
- E 709 Guide for Magnetic Particle Examination<sup>6</sup>

### 3. Terminology

#### 3.1 Definitions:

3.1.1 The definitions in Test Methods and Definitions A 370, Test Methods, Practices, and Terminology A 751, and Terminology A 941 are applicable to this specification and those listed in 1.1.

<sup>5</sup> Annual Book of ASTM Standards, Vol 01.01.

<sup>6</sup> Annual Book of ASTM Standards, Vol 03.03.

<sup>7</sup> Annual Book of ASTM Standards, Vol 03.01.

<sup>8</sup> Annual Book of ASTM Standards, Vol 03.05.

### 4. Materials and Manufacture

4.1 *Melting Process*—The steel shall be made by open-hearth or electric furnace process with or without separate refining such as argon-oxygen-decarburization (AOD) unless otherwise specified in the individual specification.

#### 4.2 Heat Treatment

4.2.1 Castings shall be heat treated in the working zone of a furnace that has been surveyed in accordance with Test Method A 991/A 991M.

4.2.2 When castings are heat treated at temperatures above 2000°F (1100°C), then the working zone shall have been established by a survey performed at not more than 25°F (15°C) below nor more than 200°F (110°C) above the minimum heat treatment temperature specified for the grade. If a minimum heat treatment temperature is not specified for the grade, then the survey temperature shall be not more than 50°F (30°C) below nor more than 175°F (100°C) above the furnace set point used.

4.2.3 The maximum variation in measured temperature as determined by the difference between the highest temperature and the lowest temperature shall be as agreed between the purchaser and producer except that during production heat treatment no portion of the furnace shall be below the minimum specified temperature nor above the maximum specified temperature for the grade being processed.

### 5. Chemical Composition

5.1 *Chemical Analysis*—Chemical analysis of materials covered by this specification shall be in accordance with Test Methods, Practices, and Terminology A 751.

5.2 *Heat Analysis*—An analysis of each heat shall be made by the manufacturer to determine the percentages of the elements specified in the individual specification for the grade being poured. The analysis shall be made from a test sample preferably taken during the pouring of the heat. When drillings are used, they shall be taken not less than ¼ in. [6.4 mm] beneath the surface. The chemical composition thus determined shall conform to the requirements in the individual specification for the grade being poured.

5.3 *Product Analysis*—A product analysis may be made by the purchaser from material representing each heat, lot, or casting. The analysis shall be made on representative material. Samples for carbon analysis of carbon and alloy steel shall be taken no closer than ¼ in. to a cast surface, except that castings too thin for this shall be analyzed on representative material. The chemical composition thus determined shall meet the requirements specified in the applicable specification for the grade involved, or shall be subject to rejection by the purchaser, except that the chemical composition determined for carbon and low alloy steel castings may vary from the specified limits by the amounts shown in Table 1. The product analysis tolerances of Table 1 are not applicable as acceptance criteria for heat analysis by the casting manufacturer. When comparing product and heat analysis for other than carbon and low alloy steels, the reproducibility Data  $R_2$ , in Test Methods E 353 or E 354, as applicable, shall be taken into consideration.



TABLE 1 Product Analysis Tolerances

Element	Range, % <sup>A</sup>	Tolerances <sup>B, C</sup> Over Maximum or Under Minimum Limit, %
C	up to 0.65 above 0.65	$0.03 \times \% C_L + 0.02$ 0.04
Mn	up to 1 above 1	$0.08 \times \% Mn_L + 0.01$ 0.09
Si	up to 0.60 above 0.60	$0.22 \times \% Si_L - 0.01$ 0.15
P	all	$0.13 \times \% P_L + 0.005$
S	all	$0.36 \times \% S_L + 0.001$
Ni	up to 2 above 2	$0.10 \times \% Ni_L + 0.03$ 0.25
Cr	up to 2 above 2	$0.07 \times \% Cr_L + 0.04$ 0.18
Mo	up to 0.6 above 0.6	$0.04 \times \% Mo_L + 0.03$ 0.06
V	up to 0.25 above 0.25	$0.23 \times \% V_L + 0.004$ 0.06
W	up to 0.10 above 0.10	$0.08 \times \% W_L + 0.02$ 0.02
Cu	up to 0.15 above 0.15	$0.18 \times \% Cu_L + 0.02$ 0.05
Al	up to 0.10 above 0.10	$0.08 \times \% Al_L + 0.02$ 0.03

<sup>A</sup> The range denotes the composition limits up to which tolerances are computed by the equation, and above which the tolerances are given by a constant.

<sup>B</sup> The subscript <sub>L</sub> for the elements in each equation indicates that the limits of the element specified by the applicable specification are to be inserted into the equation to calculate the tolerance for the upper limit and the lower limit (if applicable), respectively. Examples of computing tolerances are presented in footnote C.

<sup>C</sup> To illustrate the computation of the tolerance, consider the manganese maximum of 0.70 for an 0.30 carbon grade 65–35 in Specification A 27/A 27M. The maximum permissible deviation is  $(0.08 \times 0.70 + 0.01) = 0.066$ . Therefore, the highest acceptable product analysis is 0.766. Similarly, for an 0.20 carbon grade 70–40 in Specification A 27/A 27M, the maximum manganese content is 1.40; thus, the highest acceptable product analysis is  $(1.40 + 0.09) = 1.49$ .

**5.4 Unspecified Elements**—When chemical analysis for elements not specified for the grade ordered is desired, Supplementary Requirement S13 may be specified.

**5.4.1 Grade substitution**, for stainless steel or nickel base alloy castings, is not permitted. Grade substitution occurs when the material supplied:

(1) contains an element, other than nitrogen, that is not specified in the ordered grade; and,

(2) the amount of that element equals or exceeds the minimum requirement for the element in another grade for which it is specified.

For this requirement, a grade is defined as an alloy described individually in a table of chemical requirements within any specification listed within the scope of A 781/A 781M.

## 6. Mechanical Test Requirements

**6.1** The individual product specifications vary as to whether mechanical tests are required; for this reason, and to determine specific test requirements, the individual product specification should be reviewed.

**6.2** Unless otherwise specified by the purchaser, when mechanical properties are required by the product specification, test coupons may be cast integrally with the castings, or as separate blocks, in accordance with Fig. 1, Fig. 2, or Fig. 3

except when Supplementary Requirement S15 is specified. The test coupon in Fig. 3 shall be employed only for austenitic alloy castings with cross sections less than 2½ in.<sup>9</sup>

## 7. Workmanship, Finish, and Appearance

**7.1** All castings shall be made in a workmanlike manner and shall conform to the dimensions on drawings furnished by the purchaser before manufacture is started. If the pattern is supplied by the purchaser, the dimensions of the casting shall be as predicated by the pattern.

## 8. Quality

**8.1** The surface of the casting shall be free of adhering sand, scale, cracks, and hot tears as determined by visual examination. Other surface discontinuities shall meet the visual acceptance standards specified in the order. Practice A 802/A 802M or other visual standards may be used to define acceptable surface discontinuities and finish. Unacceptable visual surface discontinuities shall be removed and their removal verified by visual examination of the resultant cavities.

**8.2** When additional inspection is desired, Supplementary Requirements S1, S2, S3, S4, or S5 may be specified.

**8.3** The castings shall not be peened, plugged or impregnated.

## 9. Repair

**9.1** Repair by welding shall be in accordance with the requirements of the individual specification using procedures and welders qualified in accordance with Practice A 488/A 488M.

## 10. Inspection

**10.1** The manufacturer shall afford the purchaser's inspector all reasonable facilities necessary to satisfy that the material is being produced and furnished in accordance with the applicable specification. Foundry inspection by the purchaser shall not interfere unnecessarily with the manufacturer's operations. All tests and inspections, with the exception of product analysis (5.3), shall be made at the place of manufacture unless otherwise agreed.

## 11. Rejection

**11.1** Subsequent to acceptance at the manufacturer's works, material which is found to be unacceptable as determined by requirements specified in the order may be rejected by the purchaser. The manufacturer should be notified of such rejection. If the manufacturer is dissatisfied with the results of any tests performed by the purchaser, he may make claim for a reheating.

## 12. Keywords

12.1 castings; common requirements; steel and alloy

<sup>9</sup> Information on the relationship of mechanical properties determined on test coupons obtained as specified in 6.2 with those obtained from the casting may be found in "The Steel Casting Handbook," Fifth Edition, Steel Founders' Society of America, pp. 15–35 through 15–43, 1980.

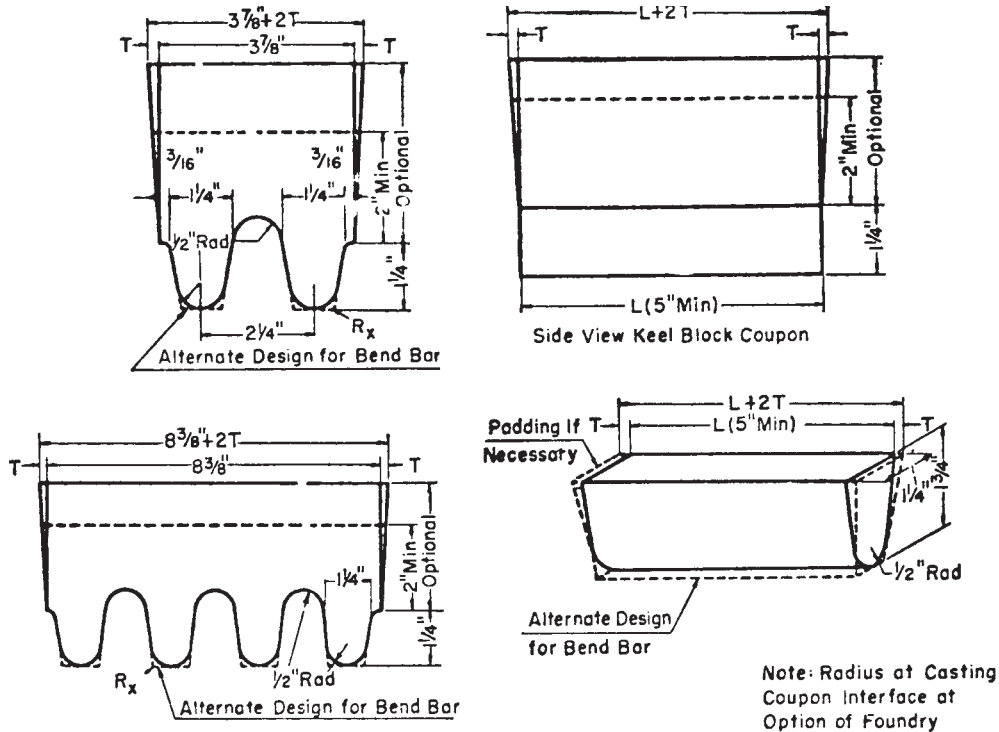

Note: Radius at Casting Coupon Interface at Option of Foundry

Metric Equivalents

in.	3/16	1/2	1 1/4	1 3/4	2	2 1/4	3 7/8	5	8 3/8
[mm]	[4.8]	[13]	[32]	[45]	[51]	[57]	[98]	[127]	[213]

Leg Design [125 mm]

Riser Design

1. L (length)	A 5 in. [125 mm] minimum length will be used. This length may be increased at the option of the foundry to accommodate additional test bars (see Note 1).	1. L (length)	The length of the riser at the base will be the same as the top length of the leg. The length of the riser at the top therefore depends on the amount of taper added to the riser.
2. End Taper	Use of and size of end taper is at the option of the foundry.	2. Width	The width of the riser at the base of a multiple-leg coupon shall be $n(2\frac{1}{4}) [57 \text{ mm}] - \frac{5}{8} [16 \text{ mm}]$ where $n$ equals the number of legs attached to the coupon. The width of the riser at the top is therefore dependent on the amount of taper added to the riser.
3. Height	1 1/4 in. [32 mm]		
4. Width (at top)	1 1/4 [32 mm] (see Note 1).		
5. Radius (at bottom)	1/2 in. [13 mm], max		
6. Spacing between legs	A 1/2-in. [13-mm] radius will be used between the legs.		
7. Location of test bars	The tensile, bend, and impact bars will be taken from the lower portion of the leg (see Note 2).		
8. Number of legs	The number of legs attached to the coupon is at the option of the foundry providing they are equi-spaced according to Item 6.	3. T (riser taper)	Use of and size is at the option of the foundry. The minimum height of the riser shall be 2 in. [51 mm]. The maximum height is at the option of the foundry for the following reasons: (a) many risers are cast open. (b) different compositions may require variation in risering for soundness. (c) different pouring temperatures may require variation in risering for soundness.
9. R <sub>s</sub>	Radius from 0 to approximately 1/16 in. [2 mm].	Height	

NOTE 1—*Test Coupons for Large and Heavy Steel Castings:* The test coupons in Fig. 1 are to be used for large and heavy steel castings. However, at the option of the foundry the cross-sectional area and length of the standard coupon may be increased as desired.

NOTE 2—*Bend Bar:* If a bend bar is required, an alternate design (as shown by dotted lines in Fig. 1) is indicated.

FIG. 1 Test Coupons for Castings with Details of Design

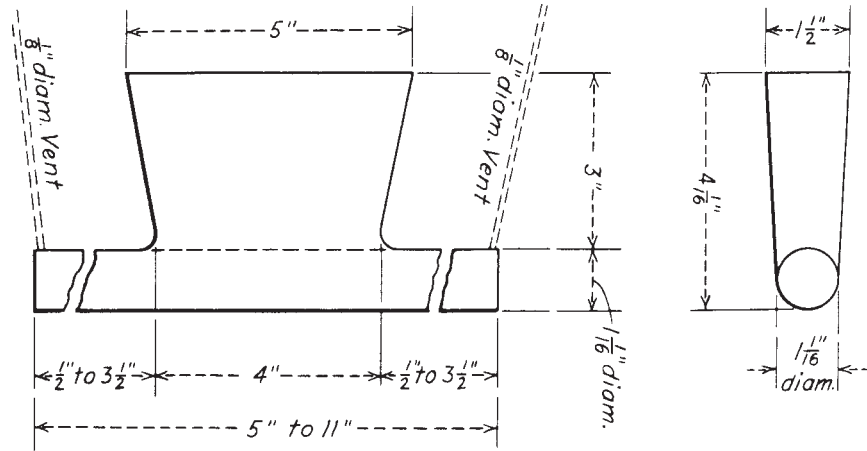

Metric Equivalents

in.	[mm]	in.	[mm]
1/6	[3.2]	3 1/2	[88.9]
1/2	[12.7]	4	[101.6]
1 1/16	[27.0]	4 1/16	[103.2]
1 1/2	[38.1]	5	[127.0]
3	[76.2]	11	[279.4]

NOTE—Pour through head; cover molten head with powdered charcoal, coke dust, and so forth, immediately after pouring, in order to keep head fluid as long as possible.

FIG. 2 Test Block for Tension Test Specimen

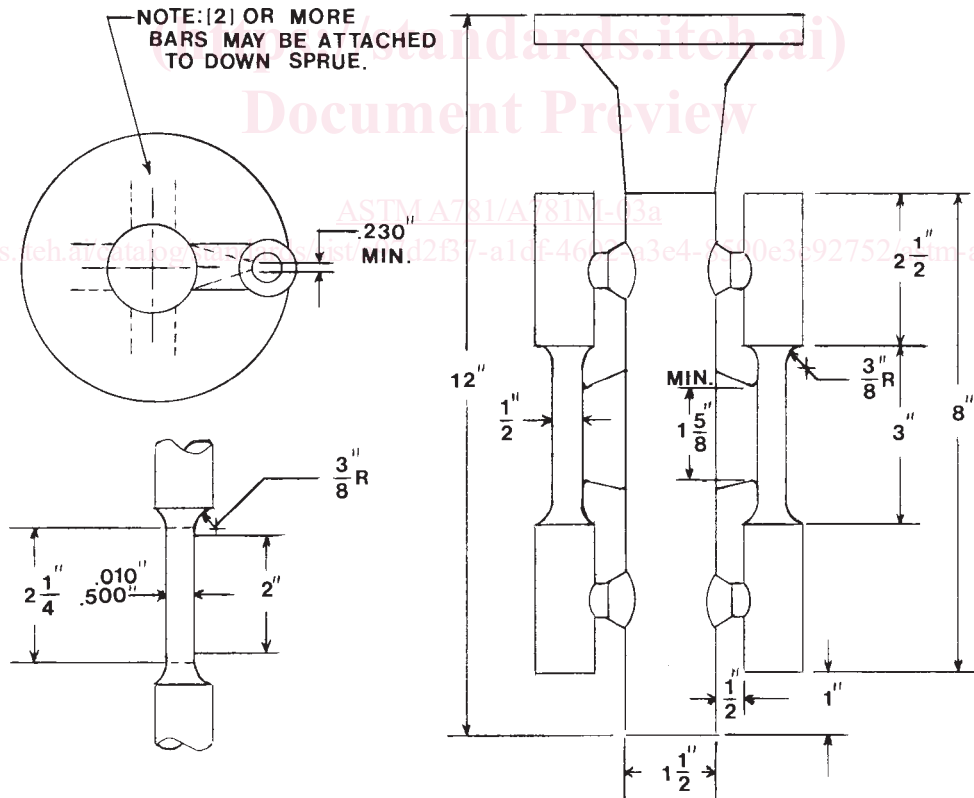

NOTE—Coupons produced in this manner are suitable for austenitic alloys only. The mold may be preheated for pouring to produce a sound coupon.

FIG. 3 Cast-To-Shape Test Coupon for Tension Specimen



## SUPPLEMENTARY REQUIREMENTS

Supplementary requirements shall be applied only when specified by the purchaser. Details of the supplementary requirements shall be agreed upon by the manufacturer and purchaser. The specified tests shall be performed by the manufacturer prior to shipment of the castings.

### S1. Magnetic Particle Examination

S1.1 Castings shall be examined for surface and near surface discontinuities by magnetic particle examination. The examination shall be in accordance with Guide E 709. Extent of examination and the basis for acceptance shall be agreed upon between the manufacturer and purchaser.

### S2. Radiographic Examination

S2.1 Castings shall be examined for internal defects by means of X rays or gamma rays. The procedure shall be in accordance with Guide E 94, and types and degrees of discontinuities considered shall be judged by Reference Radiographs E 446, E 186, or E 280. Extent of examination and basis for acceptance shall be agreed upon between the manufacturer and purchaser.

### S3. Liquid Penetrant Examination

S3.1 Castings shall be examined for surface discontinuities by means of liquid penetrant examination. The examination shall be in accordance with Test Method E 165. Areas to be inspected, methods and types of liquid penetrants to be used, developing procedure, and basis for acceptance shall be agreed upon between the manufacturer and purchaser.

### S4. Ultrasonic Examination

S4.1 Castings shall be examined for internal defects by means of ultrasonic examination. The examination procedure shall be in accordance with Practice A 609/A 609M. Extent of examination, methods of testing, and basis for acceptance shall be agreed upon between the manufacturer and purchaser.

### S5. Examination of Weld Preparation

S5.1 Magnetic particle or liquid penetrant examination of cavities prepared for welding shall be performed to verify removal of those discontinuities found unacceptable by the examination method specified for the casting. Unless other degrees of shrinkage or types of discontinuities found in the cavities are specified, Type II, Internal Shrinkage, of Reference Photographs E 125, of Degree 2 in sections up to 2 in. [50.8 mm] thick and of Degree 3 in sections over 2 in. thick shall be acceptable.

### S6. Certification

S6.1 The manufacturer's certification shall be furnished to the purchaser stating that the material was manufactured, sampled, tested, and inspected in accordance with the material specification (including year date) and was found to meet the requirements.

S6.2 A manufacturer's certification printed from or used in electronic form from an electronic data interchange (EDI) transmission shall be regarded as having the same validity as a

counterpart printed in the certifier's facility provided it conforms to any existing EDI agreement between the purchaser and the supplier.

### S7. Prior Approval of Major Weld Repairs

S7.1 Major weld repairs as defined and agreed upon between the manufacturer and purchaser shall be subject to the prior approval of the purchaser.

### S8. Marking

S8.1 The manufacturer's name or identification mark and the pattern number shall be cast or stamped on all castings. When further specified, the heat numbers or serial numbers shall be marked on individual castings.

### S9. Charpy Impact Test

S9.1 Charpy impact test properties shall be determined by testing a set of three Charpy V-notch specimens made from each heat at a test temperature agreed upon by the manufacturer and purchaser. The material from which the test specimens are prepared shall be cast in accordance with 6.2. The acceptance requirements shall be either energy absorbed, lateral expansion, or percent shear area, or all three, and shall be that agreed upon between the manufacturer and purchaser. Test specimens shall be prepared as Type A and tested in accordance with Test Methods and Definitions A 370.

S9.2 *Absorbed Energy*—Average energy value of three specimens shall be not less than specified, with not more than one value permitted to fall below the minimum specified and no value permitted below the minimum specified for a single specimen.

S9.3 *Lateral Expansion*—Lateral expansion value shall be agreed upon between the manufacturer and purchaser.

S9.4 *Percent Shear Area*—Percent shear area shall be agreed upon between the manufacturer and purchaser.

### S10. Hardness Test

S10.1 Hardness measurements at specified locations of the castings shall be made in accordance with Test Methods and Definitions A 370 and reported.

### S11. Specified Ferrite Content Range

S11.1 The chemical composition of the heat shall be controlled such that the ferrite content, as determined by the chemical composition procedure of Practice A 800/A 800M, shall be in conformance with the specified ferrite content range.

S11.2 The specified ferrite content range shall be as agreed upon between the manufacturer and the purchaser. The minimum specified ferrite content range shall be 10 % with the minimum ferrite content being no lower than the percent