



Designation: F 1223 – 03

Standard Test Method for Determination of Total Knee Replacement Constraint¹

This standard is issued under the fixed designation F 1223; the number immediately following the designation indicates the year of original adoption or, in the case of revision, the year of last revision. A number in parentheses indicates the year of last reapproval. A superscript epsilon (ϵ) indicates an editorial change since the last revision or reapproval.

1. Scope

1.1 The purpose of this test method is to establish a database of total knee replacement (TKR) motion characteristics with the intent of developing guidelines for the assignment of constraint criteria to TKR designs. (See the Rationale in [Appendix X1](#).)

1.2 This test method covers the means by which a TKR constraint may be quantified according to motion delineated by the inherent articular design as determined while under specific loading conditions in an *in vitro* environment.

1.3 Tests deemed applicable to the constraint determination are antero-posterior draw, medio-lateral shear, rotary laxity, valgus-varus rotation, and distraction, as applicable. Also covered is the identification of geometrical parameters of the contacting surfaces which would influence this motion and the means of reporting the test results. (See Practices E 4E 4.)

1.4 *This standard does not purport to address all of the safety concerns, if any, associated with its use. It is the responsibility of the user of this standard to establish appropriate safety and health practices and determine the applicability of regulatory limitations prior to use.*

2. Referenced Documents

- 2.1 *ASTM Standards*:
[E 4 Practices for Force Verification of Testing Machines](#)²
[F 2083 Specification for Total Knee Prosthesis](#)³

3. Terminology

3.1 *Definitions*—Items in this category refer to the geometrical and kinematic aspects of TKR designs as they relate to their human counterparts:

3.1.1 *anterior curvature*—a condylar design which is generally planar except for a concave—upward region anteriorly on the tibial component.

3.1.2 *anterior posterior (AP)*—any geometrical length aligned with the AP orientation.

3.1.3 *AP displacement*—the relative linear translation between components in the AP direction.

3.1.4 *AP draw load*—the force applied to the movable component with its vector aligned in the AP direction causing or intending to cause an AP displacement.

3.1.5 *biconcave*—a condylar design with pronounced AP and ML condylar radii seen as a “dish” in the tibial component or a “toroid” in the femoral component.

3.1.6 *bearing surface*—those regions of the component which are intended to contact its counterpart for load transmission.

3.1.7 *condyles*—entity designed to emulate the joint anatomy and used as a bearing surface primarily for transmission of the joint reaction force with geometrical properties which tend to govern the general kinematics of the TKR.

3.1.8 *distraction*—the separation of the femoral component(s) from the tibial component(s) in the z-direction.

3.1.9 *flexion angle*—the angulation of the femoral component (about an axis parallel to the y-axis) from the fully extended knee position to a position in which a “local” vertical axis on the component now points posteriorly.

3.1.9.1 *Discussion*—For many implants, 0° of flexion can be defined as when the undersurface of the tibial component is parallel to the femoral component surface that *in vivo* contacts the most distal surface of the femur. This technique may not be possible for some implants that are designed to have a posterior tilt of the tibial component. In these cases, the user shall specify how the 0° of flexion position was defined.

3.1.10 *hinge*—a mechanical physical coupling between femoral and tibial components which provides a singular axis about which flexion occurs.

3.1.11 *hyperextension stop*—a geometrical feature which arrests further progress of flexion angles of negative value.

3.1.12 *internal-external rotation*—the relative angulation of the moveable component about an axis parallel to the z-axis.

3.1.13 *joint reaction force*—the applied load whose vector is directed parallel to the z-axis, generally considered parallel to tibial longitudinal axis.

3.1.14 *medio-lateral (ML)*—the orientation that is aligned with the y-axis in the defined coordinate system.

¹ This test method is under the jurisdiction of ASTM Committee F04 on Medical and Surgical Materials and Devices and is the direct responsibility of Subcommittee F04.15 on Material Test Methods.

Current edition approved Apr. 10, 2003. Published June 2003. Originally approved in 1989. Last previous edition approved in 2001 as F 1223 – 01.

² *Annual Book of ASTM Standards*, Vol 03.01.

³ *Annual Book of ASTM Standards*, Vol 13.01.

3.1.15 *ML condylar radius*—the geometrical curvature of the component’s condyle in the frontal plane.

3.1.16 *ML dimension*—any geometrical length aligned with the ML orientation.

3.1.17 *ML displacement*—the relative linear translation between components in the ML direction.

3.1.18 *ML shear load*—the force applied to the moveable component with its vector aligned in the ML direction causing or intending to cause an ML displacement.

3.1.19 *post-in-well feature*—a TKR design which tends to influence kinematics through the coupling of a prominent eminence with a recess or housing in a mating component.

3.1.20 *rotary laxity (RL)*—degree of relative angular motion permitted of moveable component about the z-axis as governed by inherent geometry and load conditions.

3.1.21 *rotary torque*—the moment applied to the moveable component with its vector aligned to an axis parallel to the z-axis and causing or intending to cause an internal or external rotation.

3.1.22 *tibial eminence*—a raised geometrical feature separating the tibial condyles.

3.1.23 *valgus-varus constraint*—degree of relative angular motion allowed between the femoral and tibial components of post-in-well designs (or similar designs) in the coronal plane.

3.2 *Definitions of Terms Specific to This Standard:*

3.2.1 *constraint*—the relative inability of a TKR to be further displaced in a specific direction under a given set of loading conditions as dictated by the TKR’s geometrical design. This motion is limited, as defined in this test, to the available articular or bearing surfaces found on the tibial component. The actual relative motion values will be provided as an indicator of this type of constraint.

3.2.2 *coordinate system* (see Fig. 1)—a set of arbitrary cartesian coordinates affixed to the stationary component and aligned such that the origin is located at the intersection of the y and z axes.

3.2.2.1 *Discussion*—The y-axis is parallel to the ML direction, directed medially, and is coincident with the mated components’ contact points when the knee is in the neutral position (see 7.2). The z-axis is located midway between the mated components’ contact points (or in the case of a singular contact point, located at that point) and aligned in the superior-inferior direction of the distal component. A third axis, x, mutually orthogonal to the two previous axes is directed posteriorly. For determination of contact points, see Annex A1 and Fig. 2. The contact point shall be located to a tolerance of ±1 mm. In the case of multiple contact points on a condyle, an average location of the contact points shall be used.

3.2.3 *degrees of freedom*—although the knee joint is noted to have 6 df, or directions in which relative motion is guided (three translations: AP, ML, vertical; three angulations: flexion, internal-external rotation, valgus-varus), the coupling effects due to geometrical features reduce this number to five which are the bases of this test method: AP draw, ML shear, internal-external rotation, valgus-varus rotation, and distraction.

3.2.4 *neutral position* (see 7.2)—that position in which the TKR is at rest with no relative linear or angular displacements between components.

3.2.4.1 *Discussion*—This is design-dependent and there may be a unique neutral position at each flexion angle. It may be indicated that the femoral component, when implanted, be positioned at some angle of hyperextension as seen when the

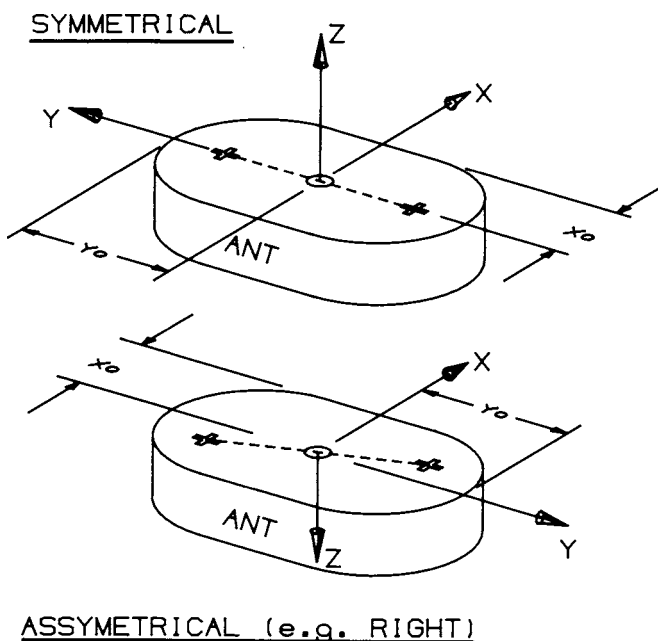
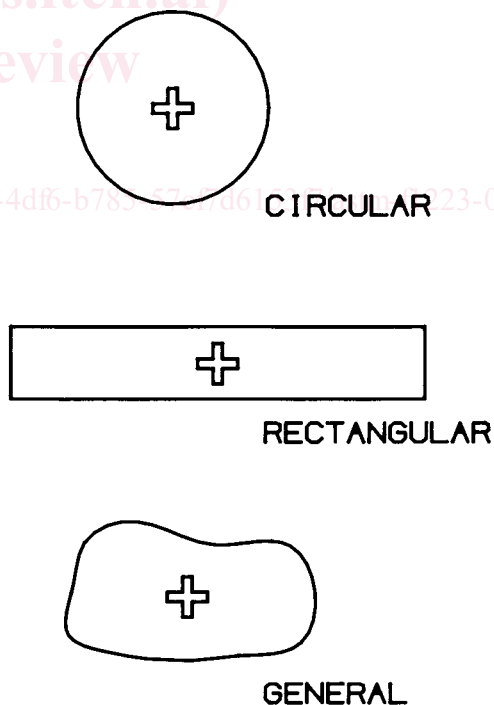

FIG. 1 Defined Coordinate System Examples



CONTACT POINT (+) IS CENTROID OF CONTACT AREA
 FIG. 2 Tibial Condyle Contact Point Location Examples

patient's knee is fully extended; this, then becomes the neutral position for negative flexion angle tests. The neutral position may be determined by either applying a compressive force of 100 N and allowing the implant to settle or by measuring the vertical position of the movable component with respect to the stationary and using the low point of the component as the neutral point. In those implants with a flat zone and no unique low point, the midpoint of the flat zone can be used as the neutral point. For those implants having a tibial component with a posterior tilt, the user may use other means to define the neutral point, but will report on how it was found.

3.2.5 *set point*—that numeric quantity assigned to an input such as a load.

3.2.6 *movable component*—that component identified either through design or test equipment attributes as providing the actual relative motion values.

3.2.6.1 *Discussion*—Depending upon the user's fixtures and the stationary component, it can be either the tibial or femoral component.

3.2.7 *stationary component*—that component identified either through design or test equipment attributes as being at rest during that test to which actual relative motion values are referenced.

3.3 *Symbols: Parameters*—

3.3.1 *TAP*—overall AP tibial surface dimension.

3.3.2 *TML*—overall ML tibial surface dimension.

3.3.3 *x, y, z*—axes of neutral position coordinate system as defined in [Annex A1](#).

3.3.4 *DIST*—a “yes/no” response to distraction test at the reported angle at which distraction is most likely to occur.

4. Significance and Use

4.1 This test method, when applied to available products and proposed prototypes, will attempt to provide a database of product functionality capabilities (in light of the suggested test

regimens) that is hoped to aid the physician in making a more informed total knee replacement (TKR) selection.

4.2 A proper matching of TKR functional restorative capabilities and recipient's (patient's) needs is more likely provided for by a rational testing protocol of the implant in an effort to reveal certain device characteristics pertinent to the selection process.

4.3 The TKR product designs are varied and offer a wide range of constraint (stability). The constraint of the TKR in the *in vitro* condition is dependent on several geometrical and kinematic interactions among the implant's components which can be identified and quantified. The degree of TKR's kinematic interactions should correspond to the recipient's needs as determined by the physician during clinical examination.

5. Apparatus

5.1 *General:*

5.1.1 The stationary component should be free to move only in directions parallel to the z-axis and not permitted to rotate about this axis in all but the distraction test. In the distraction test it is fully fixed.

5.1.2 The movable component shall be the displaced member when under loads specific to that test and shall be instrumented accordingly to obtain data pertinent to that test.

5.1.3 Load or torque actuators producing input vectors which tend to displace the movable component relative to the stationary component according to the guidelines of the specific tests shall be provided with a means of gradually applying the load or torque to the set point of that test.

5.1.4 Displacement sensing devices shall be arranged so as to measure relative motion between components in accordance with the prescribed coordinate system.

5.1.5 Output graphs depicting the relationship of load and displacement are required (See [Fig. 3](#).)

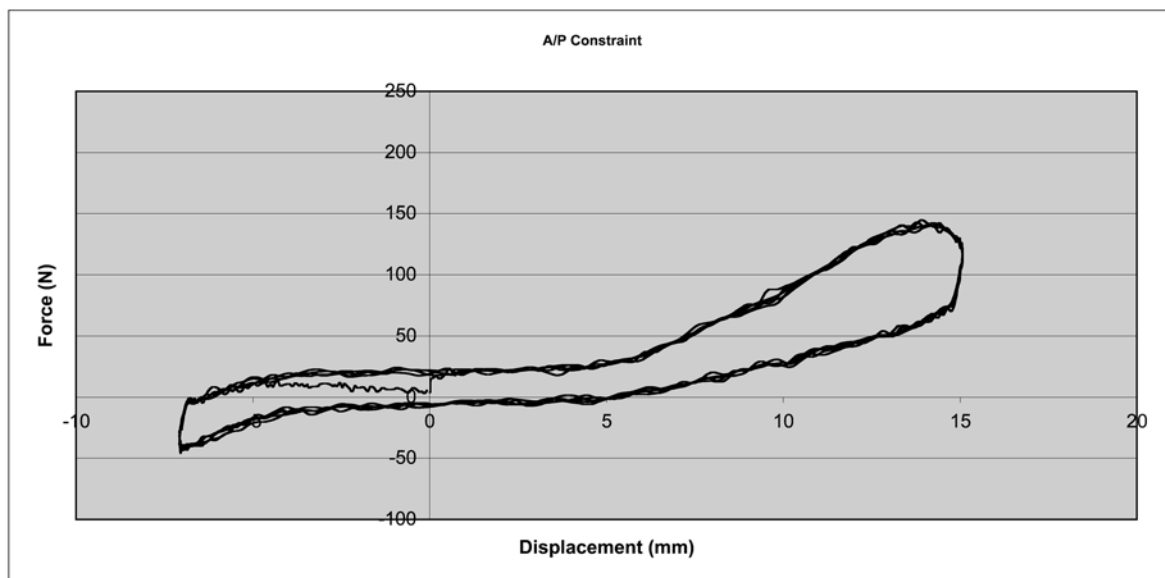

FIG. 3 Output Graph Example

5.1.6 The moveable component shall be mounted on a fixture with near zero friction or the effect of that friction must be subtracted from the applied force.

5.1.7 *Tibial Tray Alignment*—The tibial tray shall be mounted to reflect the recommended amount of posterior slope, if any.

5.1.8 The femoral component alignment shall be mounted according to the manufacturer’s specifications, such that during flexion both femoral condyles are in contact with the tibial condyles.

5.2 *Antero-Posterior Draw Test*—The movable component shall be rigidly set in a fixture free to move in linear directions parallel to the *x*-axis only.

5.3 *Medio-Lateral Shear Test*—The movable component shall be rigidly set in a fixture free to move in linear directions parallel to the *y*-axis only.

5.4 *Rotary Laxity Test*—The movable component shall be rigidly set in a fixture free to move in angular displacements about an axis parallel to the *z*-axis only.

5.5 *Distraction Test:*

5.5.1 The movable component shall be rigidly set in a fixture free to move in only those directions tending to permit such distraction. Should distraction be possible at more than one angle of flexion the test should be conducted at that angle which would most likely permit the distraction.

5.5.2 The stationary component shall be rigidly set in a fixture and not permitted to move in those directions allowed to the movable component.

5.6 *Valgus-Varus Test:*

5.6.1 Install the tibial component in a fixture in which it is either completely fixed, or free to translate linearly in a medial-lateral direction (*y*-direction) and anterior-posterior direction (*x*-direction).

5.6.2 Install the femoral component in a fixture such that it is free to rotate in the coronal plane (*yz*-plane). If the tibial component is fixed, then the femoral component must be free to translate medial laterally and anterior posteriorly. The femoral component must be free to lift off of one condyle while the other condyle remains in contact.

6. Test Specimens

6.1 *TKR Specimens:*

6.1.1 The TKR should be the manufacturer’s designated “standard” or “medium” size as this is more suitable to the loading regimes encountered in the tests.

6.1.2 The implant shall be procured in its original packaging as supplied to the user by the manufacturer.

6.1.3 If the implant is not available in its package state, the condition of the device must meet all geometry and material specifications, but may contain slight surface irregularities (that is, “cosmetic rejects”) not considered influential in those regions of the device deemed critical to the specific test.

6.2 *TKR Prototype*—The implant shall be of quality as in 6.1.3.

7. Sample Measurement

7.1 *General:*

7.1.1 The constraint values refer to the relative ability of the components to be displaced under the loads applied while

guided by the geometrical features inherent in the component design. These features are herein identified as being solely based on bearing surfaces, although certain designs offer enhanced constraint (stability) due to other structures. The tibial bearing surfaces are used as a reference for relative displacement since the components should not move beyond the limits of these features, this being disarticulation.

7.2 *Neutral Position (NP)*—The neutral position is used as the initial at-rest condition prior to any test as defined in 3.2.4. It also corresponds to the measurement coordinate system which is affixed to the stationary component and aligned along anatomical planes. The location of the origin of the coordinate system is determined in Annex A1.

7.3 *Tibial Bearing Surface Dimensions:*

7.3.1 The TML and TAP reflect the medial-lateral width and antero-posterior length of the tibial tray. Typically, TML shall be the maximum width of the implant. The TAP shall be the maximum antero-posterior dimension, typically at the medial-lateral center of the implant.

7.3.2 Overall tibial surface dimensions are measured from their projection onto the coronal or *xy*-plane. Refer to Figs. 1-6, and (TAP, TML, X_o , and Y_o).

8. Conditioning

8.1 Expose the test specimens to a clean atmosphere at a temperature of $25 \pm 5^\circ\text{C}$ for 24 h prior to testing.

8.2 At the time of the test, the tibial bearing surface will be lightly coated with a film of silicon to reduce frictional effects. Before testing, the implant must be moved cyclically three times in the desired direction before data are acquired. These three repetitions can be performed by hand or using the method described in Section 9.

8.3 The implant shall be moved a minimum of four times in the desired test direction. The data in the last repetition shall be used for analysis.

9. Procedure

9.1 *General:*

9.1.1 Distraction and valgus-varus constraint test instructions are a special case, refer to 9.5 and 9.6.

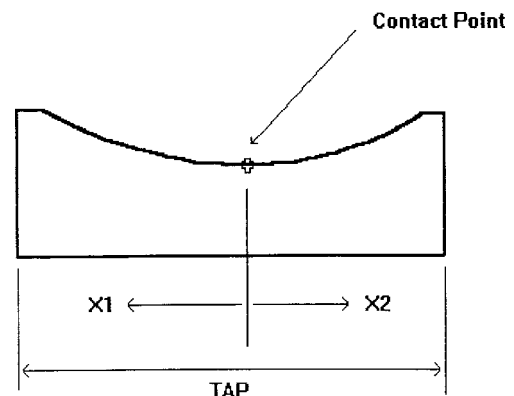

NOTE 1—Sagittal plane section view. Cut taken through the condylar contact points. Anterior is to the left.

FIG. 4 AP Dimensions and Displacement Examples