



Standard Test Method for Tearing Strength of Fabrics by Trapezoid Procedure¹

This standard is issued under the fixed designation D 5587; the number immediately following the designation indicates the year of original adoption or, in the case of revision, the year of last revision. A number in parentheses indicates the year of last reapproval. A superscript epsilon (ϵ) indicates an editorial change since the last revision or reapproval.

1. Scope

1.1 This test method covers the measurement of the tearing strength of textile fabrics by the trapezoid procedure using a recording constant-rate-of-extension-type (CRE) tensile testing machine.

1.1.1 The CRE-type tensile testing machine has become the preferred test apparatus for determining trapezoid tearing strength. It is recognized that some constant-rate-of-traverse-type (CRT) tensile testing machines continue to be used. Consequently, these test instruments may be used when agreed upon between the purchaser and the supplier. The conditions for use of the CRT-type tensile tester are included in Appendix X1.

1.2 This test method applies to most fabrics including woven fabrics, air bag fabrics, blankets, napped fabrics, knitted fabrics, layered fabrics, and pile fabrics. The fabrics may be untreated, heavily sized, coated, resin-treated, or otherwise treated. Instructions are provided for testing specimens with or without wetting.

1.3 Tearing strength, as measured in this test method, requires that the tear be initiated before testing. The reported value obtained is not directly related to the force required to initiate or start a tear.

1.4 Two calculations for trapezoid tearing strength are provided: the single-peak force and the average of five highest peak forces.

1.5 The values stated in SI units are to be regarded as the standard. The values stated in inch-pound units may be approximate.

1.6 *This standard does not purport to address all of the safety concerns, if any, associated with its use. It is the responsibility of the user of this standard to establish appropriate safety and health practices and determine the applicability of regulatory limitations prior to use.*

2. Referenced Documents

2.1 ASTM Standards:

D 76 Specification for Tensile Testing Machines for Textiles²

D 123 Terminology Relating to Textiles²

D 629 Test Methods for Quantitative Analysis of Textiles²

D 1776 Practice for Conditioning Textiles for Testing²

D 2904 Practice for Interlaboratory Testing of a Textile Test Method That Produces Normally Distributed Data²

D 2906 Practice for Statements on Precision and Bias for Textiles²

D 4848 Terminology of Force, Deformation and Related Properties of Textiles³

2.2 ASTM Adjuncts:

TEX-PAC⁴

3. Terminology

3.1 *Definitions*—For definitions of other textile terms used in this test method, refer to Terminology D 123. For definitions of other terms related to force and deformation in textiles, refer to Terminology D 4848.

3.2 *Definitions of Terms Specific to This Standard:*

3.2.1 *cross-machine direction, CD, n*—the direction in the plane of the fabric perpendicular to the direction of manufacture.

3.2.1.1 *Discussion*—This term is used to refer to the direction analogous to coursewise or filling direction in knitted or woven fabrics, respectively.

3.2.2 *fabric, in textiles, n*—a planar structure consisting of yarns or fibers.

3.2.3 *machine direction, MD, n*—the direction in the plane of the fabric parallel to the direction of manufacture.

3.2.3.1 *Discussion*—This term is used to refer to the direction analogous to walewise or warp direction in knitted or woven fabrics, respectively.

3.2.4 *peak force, in tear testing of fabrics, n*—the maximum force required to break one or more yarn components in a woven or knitted fabric specimen, or break the fiber, the fiber bonds, or fiber interlocks in other manufactured fabric forms.

3.2.4.1 *Discussion*—The peak force may consist of a single peak or a series of peaks depending upon the nature of the fabric. Typically for woven fabrics, if a small decrease in force occurs at a time when the force is increasing, it is not considered to peak unless the indicated force exceeds the force required to break a yarn. Lower shifts corresponding to yarn movement do not qualify as peaks since no yarns are broken.

¹ This test method is under the jurisdiction of ASTM Committee D-13 on Textiles and is the direct responsibility of Subcommittee D13.60 on Fabric Test Methods, Specific.

Current edition approved Feb. 10, 1996. Published April 1996.

² *Annual Book of ASTM Standards*, Vol 07.01.

³ *Annual Book of ASTM Standards*, Vol 07.02.

⁴ The PC programs on floppy disks for analyzing Committee D-13 interlaboratory data are available from ASTM. For a 3½-in. disk, request PCN:12-429040-18, and for a 5¼-in. disk, request PCN:12-429041-18.

3.2.5 *tearing force, in fabric, n*—the force required to propagate a tear initiated under specified conditions.

3.2.5.1 *Discussion*—The trapezoid tearing force may be calculated from a single peak or a multiple-peak force-extension curve.

3.2.6 *tearing strength, in fabrics, n*—the capacity of a fabric to withstand the tearing force required to propagate a tear after its initiation.

4. Summary of Test Method

4.1 An outline of an isosceles trapezoid is marked on a rectangular specimen (see Fig. 1). The specimen is slit at the center of the smallest base of the trapezoid to start the tear. The nonparallel sides of the marked trapezoid are clamped in parallel jaws of a tensile testing machine. The separation of the jaws is increased continuously to apply a force to propagate the tear across the specimen. At the same time, the force developed is recorded. The force to continue the tear is calculated from autographic chart recorders or microprocessor data collection systems.

5. Significance and Use

5.1 This test method is considered satisfactory for acceptance testing of commercial shipments since current estimates of between-laboratory precision are acceptable, and this test method is used extensively in the trade for acceptance testing.

5.1.1 In case of a dispute arising from differences in reported test results when using this test method for acceptance testing of commercial shipments, the purchaser and the sup-

plier should conduct comparative tests to determine if there is a statistical bias between their laboratories. Competent statistical assistance is recommended for the investigation of bias. As a minimum, the two parties should take a group of test specimens that are as homogeneous as possible and that are from a lot of material of the type in question. Test specimens then should be randomly assigned in equal numbers to each laboratory for testing. The average results from the two laboratories should be compared using the appropriate statistical analysis and an acceptable probability level chosen by the two parties before testing is begun. If a bias is found, either its cause must be found and corrected, or the purchaser and the supplier must agree to interpret future test results with consideration to the known bias.

5.2 The trapezoid tear produces tension along a reasonably defined course such that the tear propagates across the width of the specimen. It is useful for estimating the relative tear resistance of different fabrics or different directions in the same fabric.

5.3 Depending on the nature of the specimen, the data recording devices will show the tearing force in the form of a peak or peaks. The highest peaks appear to reflect the strength of the yarn components, individually or in combination, needed to stop a tear in fabrics of the same construction. The valleys recorded between the peaks have no specific significance. The minimum tearing force, however, is indicated to be above the lowest valleys.

5.4 Most textile fabrics can be tested by this test method. Some modification of clamping techniques may be necessary for a given fabric, depending upon its structure. Strong fabrics or fabrics made from glass fibers require special adaptation to prevent them from slipping in the clamps or being damaged as a result of being gripped in the clamps.

5.5 The CRE-type is the preferred tensile testing machine. This test method allows the use of the CRT-type tensile machine when agreed upon between the purchaser and the supplier. There may be no overall correlation, however, between the results obtained with the CRT-type machine and the CRE-type machine. Consequently, these two tensile testers cannot be used interchangeably unless the degree of quantitative correlation has been established between the purchaser and the supplier. In any event, the CRE-type machine shall prevail.

6. Apparatus

6.1 *Tensile Testing Machine*, of the CRE-type conforming to the requirements of Specification D 76 with autographic recorder, or automatic microprocessor data gathering system.

6.2 *Clamps*, having all gripping surfaces parallel, flat, and capable of preventing slipping of the specimen during a test, and measuring at least 50 by 75 mm (at least 2 by 3 in.), with the longer dimension perpendicular to the direction of application of the force.

6.2.1 The use of hydraulic pneumatic clamping systems with a minimum of 50 by 75-mm (2 by 3-in.) serrated or rubber jaw faces having a clamping force at the grip faces of 13 to 14 kN (2900 to 3111 lbf) is recommended. Manual clamping is permitted providing no slippage of the specimen is observed.

6.2.2 For some fabrics, to prevent slippage when using jaw faces other than serrated, such as rubber-faced jaws, the jaw

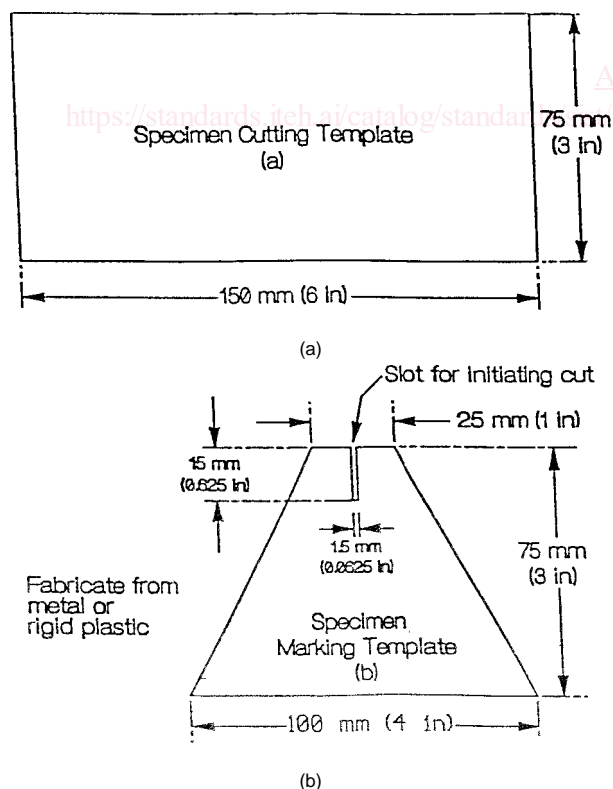

FIG. 1 Templates for Cutting and Marking Trapezoid Test Specimens

faces may be covered with a No. 80 to 120 medium-grit emery cloth. Secure the emery cloth to the jaw faces with pressure-sensitive tape.

6.3 *Cutting Die or Template*, having essentially the shape and dimensions shown in Fig. 1a.

6.4 *Trapezoid-Shaped Template*, having dimensions as shown in Fig. 1b.

7. Sampling and Test Specimens

7.1 *Lot Sample*—As a lot sample for acceptance testing, randomly select the number of rolls or pieces of fabric directed in an applicable material specification or other agreement between the purchaser and the supplier. Consider the rolls or pieces of fabric to be the primary sampling units. In the absence of such an agreement, take the number of fabric rolls specified in Table 1.

NOTE 1—An adequate specification or other agreement between the purchaser and the supplier requires taking into account the variability between rolls or pieces of fabric and between specimens from a swatch from a roll or piece of fabric to provide a sampling plan with a meaningful producer's risk, consumer's risk, acceptable quality level, and limiting quality level.

7.2 *Laboratory Sample*—For acceptance testing, take a swatch extending the width of the fabric and approximately 1 m (1 yd) along the machine direction from each roll or piece in the lot sample. For rolls of fabric, take a sample that will exclude fabric from the outer wrap of the roll or the inner wrap around the core of the roll of fabric.

7.3 *Test Specimens*—From each laboratory sampling unit, take five specimens from the machine direction and five specimens from the cross-machine direction, for each test condition described in 9.1 and 9.2, as applicable to a material specification or contract order.

7.3.1 *Direction of Test*—Consider the long direction as the direction of test.

7.3.2 *Cutting Test Specimens*—Take the specimens to be used for the measurement of machine direction with the longer dimension parallel to the machine direction. Take the specimens to be used for the measurement of the cross-machine direction with the longer dimension parallel to the cross-machine direction. When specimens are to be tested wet, take the specimens from areas adjacent to the dry test specimens. Label to maintain specimen identity.

7.3.2.1 In cutting the woven fabric specimens, take care to align the yarns running in the short direction parallel with the die such that when the slit is cut, the subsequent tear will take place between these yarns and not across them. This precaution is most important when testing bowed fabrics.

7.3.2.2 Cut specimens representing a broad distribution across the width and length, preferably along the diagonal of

the laboratory sample, and no nearer the edge than one tenth its width. Ensure specimens are free of folds, creases, or wrinkles. Avoid getting oil, water, grease, and so forth, on the specimens when handling.

7.3.2.3 Use the cutting die or template described in 6.3 and shown in Fig. 1. Mark each specimen with an isosceles trapezoid template (see Figs. 1 and 2). Make a preliminary cut 15 mm (0.625 in.) long at the center of the 25-mm (1-in.) edge, as shown in Figs. 1 and 2.

8. Preparation of Test Apparatus and Calibration

8.1 Set the distance between the clamps at the start of the test at 25 ± 1 mm (1 ± 0.05 in.).

8.2 Select the full-scale force range of the testing machine such that the maximum force occurs between 15 and 85 % of full-scale force.

8.3 Set the testing speed to 300 ± 10 mm (12 ± 0.5 in./min).

8.4 Verify calibration of the tensile testing machine as specified in the manufacturer's instructions and Specification D 76.

8.5 When using microprocessor automatic data gathering systems, set the appropriate parameters as specified in the manufacturer's instructions.

9. Conditioning

9.1 *Condition 1, for Standard Testing:*

9.1.1 Precondition the specimens by bringing them to approximate moisture equilibrium in the standard atmosphere for preconditioning textiles as specified in Practice D 1776, unless otherwise specified in a material specification or contract order.

9.1.2 After preconditioning, bring the test specimens to moisture equilibrium for testing in the standard atmosphere for testing textiles as specified in Practice D 1776 or, if applicable, in the specified atmosphere in which the testing is to be performed, unless otherwise directed in a material specification or contract order.

9.2 *Condition 2, for Wet Specimen Testing:*

9.2.1 When desizing treatments are specified prior to wet testing, use desizing treatments that will not affect the normal physical property of the fabric as specified in Test Method D 629.

9.2.2 Submerge the specimens in a container of distilled or deionized water at ambient temperature until thoroughly soaked (see section 8.2.1.1).

9.2.2.1 The time of immersion must be sufficient to wet out

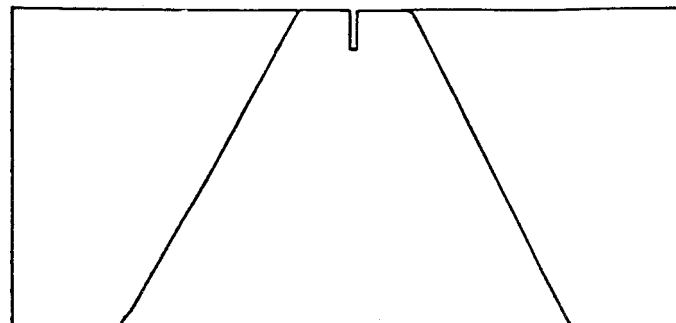

FIG. 2 Diagram of Marked Trapezoid Specimen

TABLE 1 Number of Rolls or Pieces of Fabric in the Lot Sample

Number of Rolls or Pieces in Lot, Inclusive	Number of Rolls or Pieces in Lot Sample
1 to 3	all
4 to 24	4
25 to 50	5
over 50	10 % to a maximum of 10 rolls or pieces