



Standard Test Method for Elastomer Compatibility of Lubricating Greases and Fluids¹

This standard is issued under the fixed designation D 4289; the number immediately following the designation indicates the year of original adoption or, in the case of revision, the year of last revision. A number in parentheses indicates the year of last reapproval. A superscript epsilon (ϵ) indicates an editorial change since the last revision or reapproval.

This standard has been approved for use by agencies of the Department of Defense.

1. Scope*

1.1 This test method evaluates the compatibility of lubricating greases and fluids with coupons cut from standard elastomer sheets (Practice D 3182) or, optionally, from SAE Specification AMS ~~3217/2A~~ 3217/2B (NBR-L) and AMS 3217/3A (CR) sheets. Compatibility is evaluated by determining the changes in volume and Durometer A hardness that occur when elastomer coupons are totally immersed in a lubricant sample for 70 h at either 100 or 150°C or as required by the lubricant specification.

1.1.1 Some lubricant specifications may require different test conditions, such as longer durations or lower or higher temperatures. In such instances, the repeatability and reproducibility values stated in Section 12 do not apply, and the user and supplier should agree on acceptable limits of precision.

NOTE 1—The scope of this test method now includes the evaluation of the elastomer compatibility of both lubricating fluids and greases. Testing of fluids was not included in Test Method D 4289-95 and earlier versions.

1.2 This test method can also be used as a guide to evaluate the compatibility of greases with rubber products not in standard sheet form (Practice D 3183).

1.3 The values stated in SI and Durometer A units shall be regarded as the standard.

1.4 *This standard does not purport to address all of the safety concerns, if any, associated with its use. It is the responsibility of the user of this standard to establish appropriate safety and health practices and determine the applicability of regulatory limitations prior to use.* For specific hazard warning statements, see Note 6, Note 7, and Note ~~8.4-8.6~~.

2. Referenced Documents

2.1 ASTM Standards:

D 217 Test Methods for Cone Penetration of Lubricating Grease²

D 297 Test Methods for Rubber Products—Chemical Analysis³

D 412 Test Methods for Vulcanized Rubber and Thermoplastic Elastomers—Tension³

D 471 Test Method for Rubber Property—Effect of Liquids³

D 1193 Specification for Reagent Water⁴

D 2240 Test Method for Rubber Property—Durometer Hardness³

D 3182 Practice for Rubber—Materials, Equipment, and Procedures for Mixing Standard Compounds and Preparing Standard Vulcanized Sheets³

D 3183 Practice for Rubber—Preparation of Pieces for Test Purposes from Products³

D 4175 Terminology Relating to Petroleum, Petroleum Products, and Lubricants⁵

D 4950 Classification of and Specification for Automotive Service Greases⁵

2.2 Federal Standard:

Federal Test Method Standard 791C, Method 3603.5, Swelling of Synthetic Rubbers⁶

2.3 U.S. Air Force Specification:

539 Specification Bulletin for Standard Elastomer Stocks⁷

2.4 SAE Standards:

¹ This test method is under the jurisdiction of ASTM Committee ~~D-2~~ D02 on Petroleum Products and Lubricants and is the direct responsibility of Subcommittee D02.G0 on Lubricating Grease.

Current edition approved ~~June~~ May 10, 1997; 2003. Published ~~August~~ 1997; June 2003. Originally published as ~~D4289-89~~ approved in 1989. Last previous edition ~~D4289-95~~ approved in 1997 as D 4289-97.

² Annual Book of ASTM Standards, Vol 05.01.

³ Annual Book of ASTM Standards, Vol 09.01.

⁴ Annual Book of ASTM Standards, Vol 11.01.

⁵ Annual Book of ASTM Standards, Vol 05.02.

⁶ Available from Standardization Documents Order Desk, Bldg. 4, Section D, 700 Robbins Ave., Philadelphia, PA 19111-5094, Attn: NPODS.

⁷ USAF Specification Bulletin 539 is obsolete, but reproductions are available by requesting RR: D02-1165 from ASTM Headquarters.

*A Summary of Changes section appears at the end of this standard.

AMS 3217A Standard Elastomer Stocks—Test Slabs⁸

~~AMS 3217/2A~~ **AMS 3217/2B** Test Slabs, Acrylonitrile Butadiene (NBR-L)—Low Acrylonitrile, 65–75⁸

AMS 3217/3A Test Slabs, Chloroprene (CR)—65–75⁸

NOTE 2—USAF Specification Bulletin 539 was specified in Test Method D 4289 – 94 and earlier versions. This specification is obsolete and has been replaced by SAE Standard AMS 3217A. USAF-539 NBR-L has been replaced by SAE AMS ~~3217/2A~~ **3217/2B** (NBR-L), which is virtually identical. USAF-539 CR has been replaced by the similar, but not identical, SAE AMS 3217/3A (CR). Elastomer sheets prepared to this latter specification are not known or expected to provide test results identical with those of the USAF Specification 539 ~~counterpart~~.

NOTE 3—With respect to elastomer **AMS 3217/2A**, the elastomer specification has been superseded by **AMS 3217/2B**. Per SAE, the elastomers are identical, however, the synthetic lubricant immersion fluid used to reference the elastomer has been exchanged from ARM-200 to AMS 3021. Reference fluid **AMS 3021** better represents current market aviation fluids.

3. Terminology

3.1 Definitions:

3.1.1 *elastomer, n*—a natural or synthetic polymer having the rubber-like property of substantially recovering its size and shape after removal of a deforming force.

3.1.2 *hardness, n*—of an elastomer, the resistance to deformation or indentation.

3.1.2.1 *Discussion*—In this test method the hardness of an elastomer is measured with a Shore Durometer A (see Test Method D 2240).

3.1.3 *lubricant, n*—any material interposed between two surfaces that reduces the friction or wear between them. **D 4175**

3.1.4 *lubricating grease, n*—a semifluid to solid product of a dispersion of a thickener in a liquid lubricant.

3.1.4.1 *Discussion*—The dispersion of the thickener forms a two-phase system and immobilizes the liquid lubricant by surface tension and other physical forces. Other ingredients imparting special properties are often included. **D 217**

3.1.5 *relative density, n*—the ratio of the density of a material at temperature, t_1 , to the density of water at a reference temperature, t_2 .

3.1.5.1 *Discussion*—In this test method relative density is determined with the temperature of the elastomer and water being equal and within the range from 20 to 25°C, and the temperature correction for the density of water is not applied. The term, *relative density*, replaces the synonymous, deprecated term, *specific gravity*, used in some earlier editions of this test method.

3.1.6 *thickener, n*—in a lubricating grease, a substance composed of finely divided particles dispersed in a liquid lubricant to form the product's structure.

3.1.6.1 *Discussion*—The thickener can be fibers (such as various metallic soaps) or plates or spheres (such as certain non-soap thickeners) which are insoluble or, at most, only very slightly soluble in the liquid lubricant. The general requirements are that the solid particles be extremely small, uniformly dispersed, and capable of forming a relatively stable, gel-like structure with the liquid lubricant. **D 217**

3.2 Definitions of Terms Specific to This Standard:

3.2.1 *coupon, n*—a test piece of specified dimensions cut from standard elastomer sheets (Practice sheets). **D 3182**.

3.3 Symbols:

3.3.1 Symbols used in the calculation of hardness change (see Eq 1 in 10.1):

ΔH = hardness change, Durometer A units,

H_i = initial hardness, Durometer A units,

H_f = final hardness, Durometer A units.

3.3.2 Symbols used in the calculation of relative density (see Eq 2 in 10.2) and volume change (see Eq 3 in 10.3):

RD = relative density,

ΔV = volume change, %,

M_1 = initial mass of coupon in air, g,

M_2 = initial mass of coupon and hanger wire in water less mass of hanger wire partially submerged in water, g,

M_3 = final mass of coupon in air, g,

M_4 = final mass of coupon and hanger wire in water less mass of hanger wire partially submerged in water, g.

4. Summary of Test Method

4.1 A prepared elastomer coupon is measured for initial hardness (Durometer A), density or relative density (to ensure that the coupon is within specified limits), and volume by water displacement. The coupon is immersed in test grease or fluid and aged for 70 h at either 100°C (for chloroprene and similar flex-resistant elastomers) or 150°C (for nitrile and similar heat-resistant elastomers) or at other conditions as required by the lubricant specification. The resulting changes in hardness and volume are determined.

⁸ Available from Society of Automotive Engineers, 400 Commonwealth Drive, Warrendale, PA 15096.

5. Significance and Use

5.1 Measurement of the changes in the volume and hardness of an elastomer that occur from immersion in a lubricating grease or fluid provides a means for evaluating relative compatibility. Much of this test method was derived from procedures described in Test Method D 471 and Federal Test Method 791C/3603.5. In contrast to these two test methods, which emphasize the evaluation of rubber and rubber-like compounds, Test Method D 4289 was developed specifically to evaluate lubricating greases and fluids, especially those used in automotive applications, although the test method can be applied to lubricants used in industrial applications as well. Excepting the Shore Durometer A, this test method requires no specialized, rubber-testing equipment. Virtually all other equipment and supplies specified in the procedure are stock items in lubricants laboratories.

5.2 The volume and hardness-change values determined by this test method do not duplicate similar changes that occur in elastomeric seals under actual service conditions. However, they can be correlated in many instances. In one such instance, the volume-change values determined by the antecedent of this test method correlated ($r^2 = 0.99$) with those that occurred during a vehicle test.⁹ Because of wide variations in service conditions and differences in grease and elastomer formulations, correlations between the results obtained with this test method and particular applications should be determined on an individual basis.

5.3 When the optional Reference Elastomers AMS 3217/2A3217/2B (acrylonitrile-butadiene, NBR-L) and AMS 3217/3A (chloroprene, CR) are used to evaluate compatibility, the results can be used to judge a service characteristic of lubricants. In this respect, this test method is useful for lubricant specifications (for example, Specification D 4950). Similarly, this test method can be used in specifications for lubricating fluids as well.

5.4 With specifications requiring elastomers other than Reference Elastomers AMS 3217/2A3217/2B or AMS 3217/3A, coupons cut from standard sheets (Practice D 3182) should be used. When the preparation of such coupons is not feasible, or the lubricant specification requires the use of rubber products that do not have a suitable size or configuration for use in preparing coupons for testing (Practice D 3183), this test method can be used as a guide for evaluating compatibility.

NOTE 34—Inasmuch as the precision values apply only to the elastomers specified in Annex A1 of Test Method D 4289, when a lubricant specification requires some other elastomer, the user and supplier of the lubricant should agree to the values of acceptable precision. Such values may or may not be the same as those of Test Method D 4289. It is recommended that the agreed upon precision values be stated in the user's lubricant specification.

5.5 The results of this test method are most applicable to the use of lubricating greases and fluids in contact with elastomeric seals, boots, O-rings, and similar products, where the physical demands on the elastomer are not extreme. In critical applications where the lubricant will be in contact with rubber parts subject to severe flexing, extreme temperatures, or similar stresses, other rubber properties, such as tensile strength and elongation, should also be evaluated as they may be more indicative of the true compatibility characteristics.

6. Interferences

6.1 (**Caution Warning**)—Although greases and elastomers typically have long shelf lives, there is potential for change in time. Therefore, in order to ensure acceptable precision in this test method, neither test greases nor test elastomers should be more than approximately one year old.)

6.1.1 Before testing with Reference Elastomers stored for extended periods (approaching one year or more) or in an adverse environment (high ambient temperatures, solvent vapors, and so forth), the elastomers should be checked for conformance with the requirements in Table A1.1.

NOTE 45—Experience has shown that storage conditions can affect the shelf life of the reference elastomers. Shelf life can be extended by storing elastomers in the dark in an inert atmosphere (such as a glass or metal, but not plastic, container, for example, vacuum desiccator, in which the air has been replaced by nonreactive gas (such as argon or nitrogen) at refrigerator temperatures. Elastomers should not be stored at temperatures lower than 5°C because of crystallinity and solubility changes that can affect test performance. Neither should they be stored at reduced pressures or in permeable containers or wrappers which could allow them to be affected by the normal atmosphere.

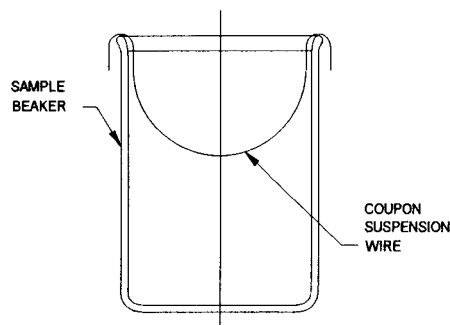

FIG. 1 Coupon Suspension Wire for Fluid Samples

⁹ Verdura, T. M., "Evaluating Compatibility of Greases with Elastomeric Seals," *NLGI Spokesman*, Vol 42, 1978, pp. 20–29.

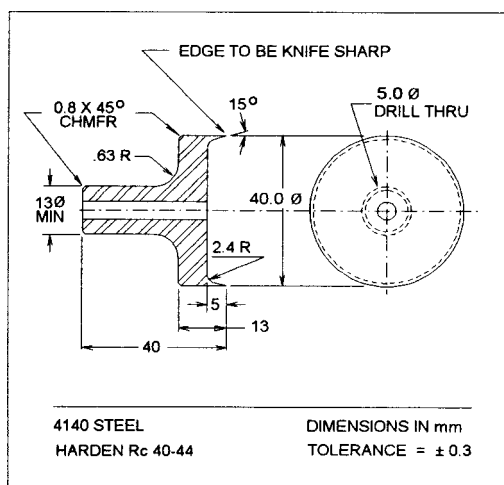

FIG. 2 Coupon Cutting Die (Optional)

7. Apparatus

7.1 *Sample Beaker*, heat-resistant glass, Griffin low form, approximately 50 mm in diameter by 70 mm deep (100-mL nominal capacity), having volumetric markings.

7.2 *Beaker Cover*, disposable, aluminum foil weighing (moisture) dish, with crimped sides and flat, smooth bottom, about 0.1 mm thick, having bottom inside diameter approximately 52 mm and a depth of approximately 14 mm, and a capacity of about 50 mL.

7.3 *Analytical Balance*, having a sensitivity of at least 1 mg, equipped with a suspension hook and a platform to locate a hydrostatic-weighing beaker above the balance pan.

7.4 *Hanger Wire*, stainless steel, about 0.5-mm diameter (No. 25 U.S. Steel Wire Gage or Imperial Wire Gage) of suitable length, having a fish-hook configuration, that is, with a suitably sized eye at one end and a hook configuration (approximately 8-mm gape) at the other.

7.5 *Coupon Suspension Wire*, stainless steel, about 0.71 to 0.72-mm diameter (No. 22 U.S. Steel Wire Gage or Imperial Wire Gage), configured as shown in Fig. 1, to suspend the coupon below the surface of a fluid sample.

7.6 *Laboratory Oven*, circulating-air type, capable of maintaining the test temperature within $\pm 2.5^\circ\text{C}$ and equipped with one or more grill-type, wire shelves.

7.7 *Shore Durometer A*, stand-mounted type (see Test Method D 2240).

7.8 *Coupon Cutting Die*, optional, as shown in Fig. 2 (recommended).

8. Reagents and Materials

8.1 *Purity of Reagents*—It is intended that reagent grade chemicals be used in all tests. Unless otherwise indicated, all reagents shall conform to the specifications of the Committee on Analytical Reagents of the American Chemical Society, where such specifications are available.¹⁰ Other grades may be used, provided it is first ascertained that the reagent is of sufficiently high purity to permit its use without lessening the accuracy of the determination.

8.2 *Purity of Water*—References to water shall be understood to mean distilled or deionized reagent water conforming to the requirements of Specification D 1193, Type III.

8.3 *Reference Elastomers*—Optional, sheets, SAE Aerospace Material Specifications AMS 3217/2A/3217/2B (acrylonitrile-butadiene, NBR-L) and AMS 3217/3A (polychloroprene, CR).

NOTE 6—Contact ASTM International for information regarding reference elastomer suppliers.¹¹

8.3.1 Although the use of SAE Reference Elastomers AMS 3217/2A and AMS 3217/3A—When placing purchase orders with suppliers, Reference Elastomers, SAE Specification AMS 3217/2B or AMS 3217/3A, respectively, must be specified to ensure shipment of the proper compound. Orders should require that each slab should be identified with the specification number, including suffix letter, and date of manufacture and should be accompanied by a report of normal inspection data for that batch.

¹⁰ *Reagent Chemicals, American Chemical Society Specifications*, American Chemical Society, Washington, DC. For suggestions on the testing of reagents not listed by the American Chemical Society, see *Analar Standards for Laboratory U.K. Chemicals*, BDH Ltd., Poole, Dorset, and the *United States Pharmacopeia and National Formulary*, U.S. Pharmacopeial Convention, Inc. (USPC), Rockville, MD.

¹¹ Contact ASTM Headquarters for information regarding reference elastomer suppliers. Request RR: D02-1166. When placing purchase orders with suppliers, Reference Elastomers, SAE Specification AMS 3217/2A or AMS 3217/3A, respectively, must be specified to ensure shipment of the proper compound. Orders should require that each slab should be identified with the specification number, including suffix letter, and date of manufacture and should be accompanied by a report of normal inspection data for that batch.

¹¹ Supporting data have been filed at ASTM International Headquarters and may be obtained by requesting Research Report RR: D02-1166.