



Designation: F 451 – 99a<sup>ε1</sup>

## Standard Specification for Acrylic Bone Cement<sup>1</sup>

This standard is issued under the fixed designation F 451; the number immediately following the designation indicates the year of original adoption or, in the case of revision, the year of last revision. A number in parentheses indicates the year of last reappraisal. A superscript epsilon ( $\epsilon$ ) indicates an editorial change since the last revision or reappraisal.

<sup>ε1</sup> NOTE—Figure 1 was editorially corrected in June 2003.

### 1. Scope

1.1 This specification covers self-curing resins used primarily for the fixation of internal orthopedic prostheses. The mixture may be used in either the predough or dough stage in accordance with the manufacturer's recommendations.

1.2 Units of premeasured powder and liquid are supplied in a form suitable for mixing. The mixture then sets in place.

1.3 While a variety of copolymers and comonomers may be incorporated, the composition of the set cement shall contain poly(methacrylic acid esters) as its main ingredient.

1.4 This specification covers compositional, physical performance, and biocompatibility as well as packaging requirements. The biocompatibility of acrylic bone cement as it has been traditionally formulated and used has been reported in the literature (1, 2).<sup>2</sup>

1.5 *This standard does not purport to address all of the safety concerns, if any, associated with its use. It is the responsibility of the user of this standard to establish appropriate safety and health practices and determine the applicability of regulatory limitations prior to use.*

### 2. Referenced Documents

#### 2.1 ASTM Standards:

- D 695 Test Method for Compressive Properties of Rigid Plastics<sup>3</sup>
- D 3835 Test Method for Determination of Properties of Polymeric Materials by Means of a Capillary Rheometer<sup>4</sup>
- E 29 Practice for Using Significant Digits in Test Data to Determine Conformance With Specifications<sup>5</sup>
- E 141 Practice for Acceptance of Evidence Based on the Results of Probability Sampling<sup>5</sup>
- F 619 Practice for Extraction of Medical Plastics<sup>6</sup>

<sup>1</sup> This specification is under the jurisdiction of ASTM Committee F04 on Medical and Surgical Materials and Devices and is the direct responsibility of Subcommittee F04.11 on Polymeric Materials.

Current edition approved May 10, 1999. Published July 1999. Originally published as F 451 – 76. Last previous edition F 451 – 95.

<sup>2</sup> The boldface numbers in parentheses refer to the list of references at the end of this standard.

<sup>3</sup> *Annual Book of ASTM Standards*, Vol 08.01.

<sup>4</sup> *Annual Book of ASTM Standards*, Vol 08.02.

<sup>5</sup> *Annual Book of ASTM Standards*, Vol 14.02.

<sup>6</sup> *Annual Book of ASTM Standards*, Vol 13.01.

F 748 Practice for Selecting Generic Biological Test Methods for Materials and Devices<sup>6</sup>

F 749 Practice for Evaluating Material Extracts by Intracutaneous Injection in the Rabbit<sup>6</sup>

F 756 Practice for Assessment of Hemolytic Properties of Materials<sup>6</sup>

F 763 Practice for Short-Term Screening of Implant Materials<sup>6</sup>

F 813 Practice for Direct Contact Cell Culture Evaluation of Materials for Medical Devices<sup>6</sup>

F 895 Practice for Agar Diffusion Cell Culture Screening for Cytotoxicity<sup>6</sup>

F 981 Practice for Assessment of Compatibility of Biomaterials (Nonporous) for Surgical Implants with Respect to Effect of Materials on Muscle and Bone<sup>6</sup>

#### 2.2 ANSI/ADA Standard:

No. 15 Specification for Acrylic Resin Teeth<sup>7</sup>

### 3. Terminology

#### 3.1 Definitions of Terms Specific to This Standard:

3.1.1 *doughing time*—the time after commencement of mixing at which the mixture ceases to adhere to a standard probe (see 7.5).

3.1.2 *exothermic or maximum temperature*—the maximum temperature of the mixture due to self-curing in a standard mold (see 7.6).

3.1.3 *extrusion*—the rate of flow of the material through a standard orifice under load (see 7.8.1).

3.1.4 *intrusion*—the distance of flow of the mixture into a standard mold under load (see 7.8.2).

3.1.5 *setting time*—the time after commencement of mixing at which the temperature of the curing mass equals the average of the maximum and ambient temperatures (see 7.7).

3.1.6 *unit*—one package or vial of premeasured powder component and one package or vial of premeasured liquid component.

### 4. Physical Requirements

#### 4.1 Liquid:

<sup>7</sup> Available from American National Standards Institute (ANSI), 25 W. 43rd St., 4th Floor, New York, NY 10036.

4.1.1 *Appearance*—The liquid shall be free of extraneous particulate matter or obvious visual contaminants in its container.

4.1.2 *Stability*—After being heated for 48 h at 60 ± 2°C, the viscosity of the liquid shall not increase by more than 10 % of its original value (see 7.3).

4.1.3 *Sterility*—The liquid, as poured from its container, shall pass the tests described in “Sterility Tests—Liquid and Ointments” (7.4) (3).

4.2 *Powder:*

4.2.1 *Appearance*—The powder shall be pourable and free of extraneous materials, such as dirt or lint (7.2.2).

4.2.2 *Sterility*—The powder, as poured from its package, shall pass the tests described in “Sterility Tests—Solids” (7.4) (2).

4.3 *Powder-Liquid Mixture:*

4.3.1 If the mixture is to be used in its predough stage, the material shall conform to the properties given in Table 1.

4.3.2 If the mixture is to be used in its dough stage, the material shall conform to the properties given in Table 1.

4.3.3 If the mixture can be used in either its predough or dough stages, separate units must be tested for compliance with 4.3.1 and 4.3.2.

4.4 *Cured Polymer*— The material after setting shall conform to the properties given in Table 2.

5. **Weights and Permissible Variations**

5.1 Weight and volume measurements shall be made on the respective powder and liquid components of five units (see 3.1). These units may be subsequently utilized in any of the nonsterile tests of this specification.

5.2 The weights, or volume of the powder and liquid components, or both, shall not deviate by more than 5 % from those stated on the package (9.2.2), of each of five units.

5.3 Where a radiopaque material is supplied for addition to the powder at the discretion of the surgeon, the weight or volume percent of the radiopaque material shall not deviate by more than 15 % from the value stated on the package (9.2.3).

6. **Sampling**

6.1 Units of powder and liquid shall be procured to provide sufficient material for all the tests of this specification. The units shall be obtained from regular retail distribution channels. Provided no repeat tests are required, this will amount to between seven and ten units.

6.2 It will only be necessary to maintain sterility in tests described in 7.4. All other tests described in this specification need not be conducted under sterile conditions.

TABLE 1 Requirements for Powder Liquid Mixture

Property	Extrusion, Viscosity Tests	Dough Usage, Intrusion Tests
Max Dough Time, min.	5.0	5.0
Setting Time Range, min.	5 to 15	5 to 15
Temperature, max., °C	90	90
Intrusion, min., mm	...	2.0

TABLE 2 Requirements for Cured Polymer After Setting

Property	Requirement
Compressive Strength, min., MPa	70

7. **Test Methods and Sample Size**

7.1 Maintain all equipment, mixing surfaces, and materials at 23 ± 2°C at least 2 h prior to testing and conduct all tests at 23 ± 2°C and 50 ± 10 % relative humidity unless otherwise specified.

7.2 *Inspection*—Use visual inspection in determining compliance to the requirements outlined in 4.1.1, 4.2.1, 8.1 and 8.2.

7.2.1 The liquid component of two separate units shall comply with the requirements of 4.1.1 and 8.1.

7.2.2 The powder component of two separate units shall comply with the requirements of 4.2.1 and 8.1.

7.3 *Liquid Component Viscosity*—Record the viscosity change of two separate units (4.1.2) before and after the heating exposure by timing the flow of the liquid level between the 0 and 5 mL marks of a 10 mL measuring pipet. Calculate the percent change as follows:

$$\% \text{ Change} = \frac{t_a - t_b}{t_b} \times 100 \quad (1)$$

where:

$t_b$  = flow time before heating, and

$t_a$  = flow time after heating exposure (4.1.2) of 60 ± 2°C for 48 h in the dark in a closed container.

7.3.1 An alternative method for viscosity may be used if it can be demonstrated to yield similar results. Both shall comply to the less than 10 % change specified (4.1.2).

7.4 The components of the two units shall be tested for sterility in accordance with the test methods described in U.S. Pharmacopoeia, “Sterility Tests” (3).

7.5 *Doughing Time:*

7.5.1 *Environment*— All equipment, mixing surfaces, and material (unit size) shall be maintained at 23 ± 1°C at least 2 h prior to testing and tests shall be conducted at 23 ± 1°C. The relative humidity shall be 50 ± 10 %.

7.5.2 Mix all the powder and liquid of a single unit together as directed by the manufacturer’s instructions (see 8.2). Start a stop watch at the onset of combining the liquid to the powder and read all subsequent times from this stop watch. Approximately 1.5 min after the onset of mixing, gently probe the mixture with a non-powdered surgically gloved (latex) finger. Take visual notice as to the formation of fibers between the surface of the mix and the finger as it leaves the surface. Repeat this process from that time on at 15 s intervals with a clean portion of the glove until the gloved finger separates cleanly. Denote the time at which this is first observed as the doughing time. Mix the mixture between determinations to expose fresh material for each probing.

7.5.3 Determine the average doughing time from two separate units.

7.5.4 The two values found shall agree within 30 s of each other, otherwise repeat the test on two additional units. Report the average of all four tests and the range of values.

7.5.5 Report the doughing time to the nearest 15 s as the average of all determinations. Maximum and minimum values

of doughing times measured shall not differ by more than  $\pm 1\frac{1}{2}$  min from the average.

7.6 *Exothermic Temperature*—Within 1 min after doughing time, gently pack approximately 25 g of the dough described in 7.5 into the mold described in Fig. 1. This mold shall be made of polytetrafluoroethylene (PTFE), poly(ethyleneterephthalate), polyoxymethylene, high density polyethylene, or ultra-high molecular weight polyethylene (UHMWPE) and be equipped with a No. 24 gage wire thermocouple, or similar device, positioned with its junction in the center of the mold at a height of 3.0 mm in the internal cavity. Immediately seat the plunger with a C-clamp or suitable press to produce the 6.0 mm specimen height. Upon producing plunger seating, remove the excess material and the C-clamp or press for the remainder of the procedure. Continuously record the temperature with respect to time from the onset of mixing the liquid and the powder until cooling is observed, Fig. 2. Report the maximum temperature recorded to the nearest 1°C. This should not exceed the value given in Table 1.

7.6.1 The maximum temperature shall be the average of two separate determinations reported to the nearest 1°C.

7.6.2 If the difference between the maximum temperature for the two determinations is greater than 5.0°C, repeat the test on two additional units and report the average of all four runs to the nearest 1°C. Individual maximum and minimum values for maximum temperature shall not differ by more than  $\pm 4^\circ\text{C}$  of the average value of all determinations.

7.7 *Setting Time*— From the continuous time versus temperature recording of 7.6, the setting time ( $T_{\text{set}}$ ) is the time when the temperature of the polymerizing mass is as follows:

$$(T_{\text{max}} + T_{\text{amb}})/2 \quad (2)$$

where:

$T_{\text{max}}$  = maximum temperature, °C, and  
 $T_{\text{amb}}$  = ambient temperature of  $23 \pm 1^\circ\text{C}$ .

7.7.1 Report the setting time to the nearest 5 s.

7.7.2 Make two separate determinations of the setting time.

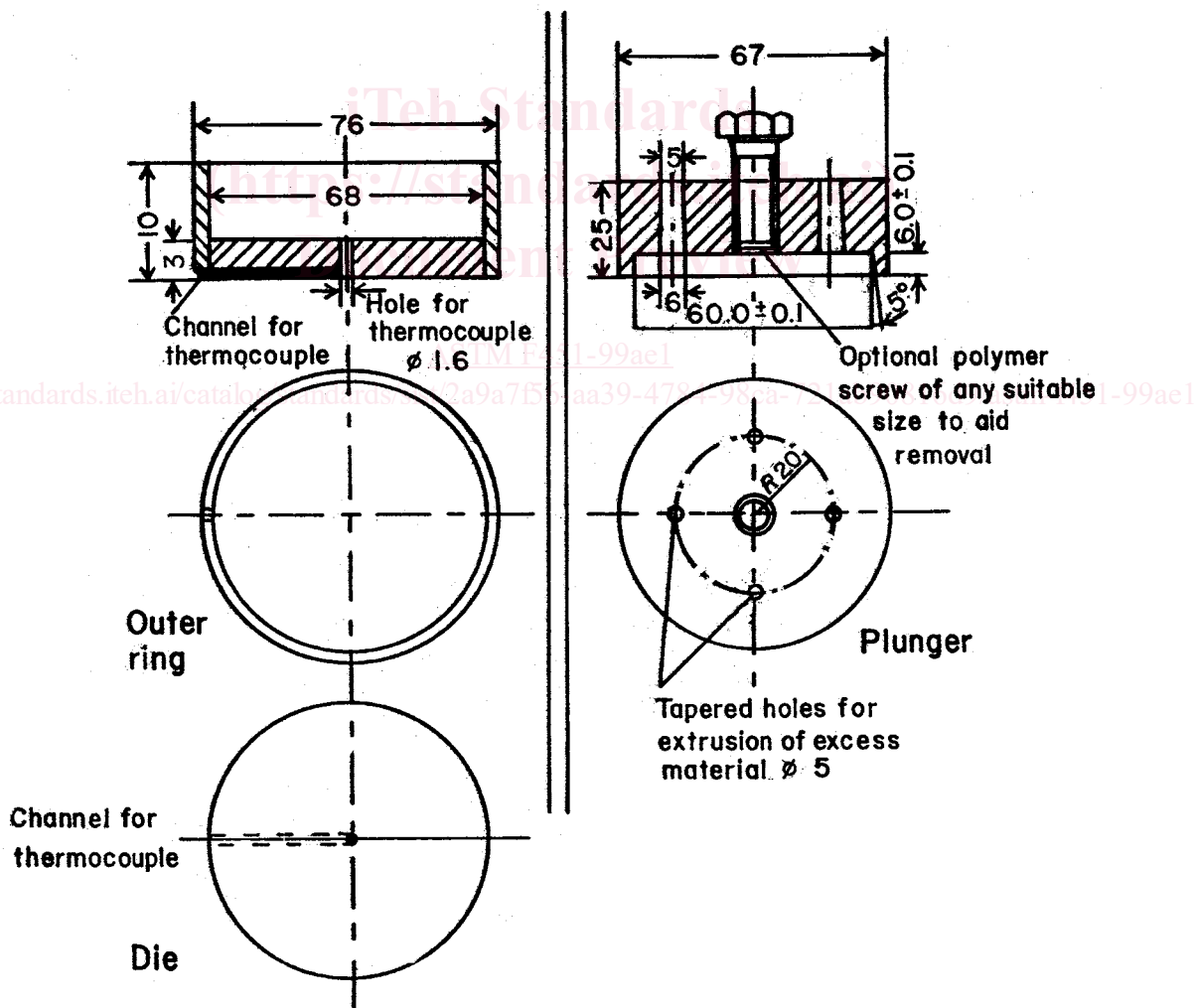

NOTE 1—Dimensions in millimetres and  $\pm 0.2$  unless otherwise specified. Material for all components: Polytetrafluoroethylene, poly(ethyleneterephthalate), polyoxymethylene, high density polyethylene, or ultra-high molecular weight polyethylene (UHMWPE).

FIG. 1 Exothermic Heat Mold

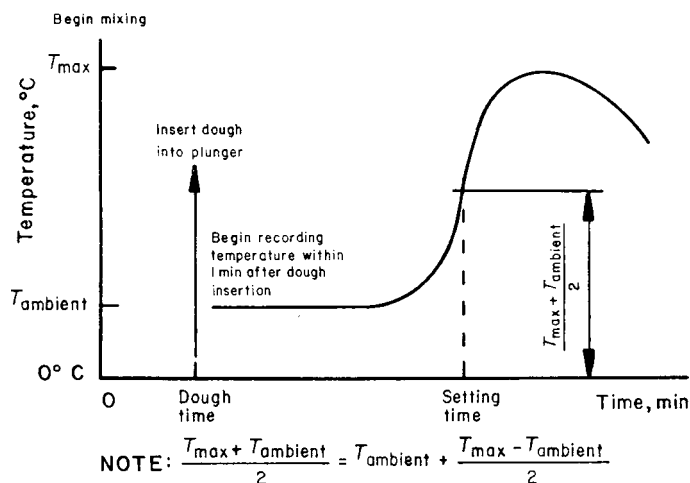

FIG. 2 Continuous Temperature Record

7.7.3 The two values should agree within 1 min of each other, otherwise repeat the test on two additional units and report the average of all runs.

7.7.4 Report the setting time to the nearest 15 s as the average of all determinations.

7.8 Flow Properties and Viscosity Determination—The manufacturer must specify whether the cement may be used in its pre-dough or dough state, or both. The determination of its usage dictates which of the following tests the cement should comply with. If the mixture is to be utilized in the pre-dough stage, use the extrusion, viscosity test (7.8.1) and Table 1. If the mixture is to be utilized in the dough stage, use the intrusion test (7.8.2) and Table 1. If the mixture is to be used as a dual usage cement, then both the extrusion (7.8.1) and intrusion (7.8.2) tests must be performed.

7.8.1 Extrusion, Viscosity:

7.8.1.1 Apparatus:

7.8.1.1.1 Rheometer—Any capillary rheometer is satisfactory in which acrylic bone cement can be forced from a reservoir through a capillary die and in which temperature, applied force, output rate, and barrel and die dimensions can be controlled and measured accurately. Equipment that provides a constant shear rate has been shown to be equally useful. The capillary die of the rheometer shall have a smooth straight bore that is held within  $\pm 0.0076$  mm ( $\pm 0.0003$  in.) in diameter and shall be held to within  $\pm 0.025$  mm ( $\pm 0.001$  in.) in length. The bore and its finish are critical. It shall have no visible drill or other tool marks and no detectable eccentricity.

7.8.1.1.2 Due to the extreme sensitivity of flow data to the capillary dimensions, it is important that the capillary dimensions are measured with precision and reported. The length to diameter ratio shall normally be between 20 and 40. Larger ratios and ratios less than that suggested require applying large corrections to the data (4, 5). In addition, the ratio of the reservoir diameter to capillary diameter should be between 3 and 15. See Test Method D 3835 for further details of capillary rheometers.

7.8.1.2 Calibration—Perform the test with a certified standard viscosity fluid approximating that expected for bone cement ( $50 \text{ N}\cdot\text{s}/\text{m}^2$  to  $500 \text{ N}\cdot\text{s}/\text{m}^2$ ). Determine the viscosity of

the standard fluid and the percent error from its specified value. Report this error along with the viscosity of the tested cements.

7.8.1.3 Corrections— Since bone cement is a non-Newtonian fluid, the data may be reported as corrected data. For example, true shear rates, corrected for non-Newtonian flow behavior and true shear stress corrected for end effects or kinetic energy losses, may be calculated. In such cases, the exact details of the mode of correction must be reported. Some correction factors which may apply are:

- (a) (a) Piston friction,
- (b) (b) Plunger back flow,
- (c) (c) Cement compressibility,
- (d) (d) Barrel back pressure,
- (e) (e) Capillary entrance effects (Bagley correction) (6),
- (f) (f) Rabinowitsch shear rate correction (7).

7.8.2 Procedure:

7.8.2.1 Select conditions of temperature and shear stress or shear rate in accordance with expected usage so that the flow rate will fall within desired limits.

7.8.2.2 Inspect the rheometer and clean it if necessary. Ensure that previous cleaning procedures and usage have not changed the dimensions or caused scratches or defects in the capillary or apparatus. Make the necessary measurements on the apparatus for future calculations. Prepare the apparatus for running the test.

7.8.2.3 Mix one or more complete unit(s) of powder and liquid in the recommended manner. Start a stop watch at the onset of mixing and read all subsequent times from this watch. After complete mixing, transfer the cement to the thermally equilibrated reservoir, and eject any entrapped air or excess bone cement.

7.8.2.4 Start the apparatus at a time not greater than  $2\frac{1}{2}$  min from the start of mixing and continue operating until the estimated dough time or the viscosity exceeds  $500 \text{ N}\cdot\text{s}/\text{m}^2$ .

7.8.2.5 Disassemble the apparatus quickly before the cement sets and clean the apparatus of all remaining cement.

7.8.3 Calculations— Perform the calculation for viscosity of the cement at time intervals of 15 s from the start to finish of test run. Use the following equations: