Pen systems —

Part 1:

**Glass cylinders for pen-injectors
for medical use**

Systèmes de stylos-injecteurs —
Partie 1: Cylindres en verre pour des stylos-injecteurs à usage médical
(standards.iteh.ai)

[ISO 13926-1:1998](https://standards.iteh.ai/catalog/standards/sist/5df08054-9a3a-480a-876d-011d3b4d9e42/iso-13926-1-1998)

<https://standards.iteh.ai/catalog/standards/sist/5df08054-9a3a-480a-876d-011d3b4d9e42/iso-13926-1-1998>



Foreword

ISO (the International Organization for Standardization) is a worldwide federation of national standards bodies (ISO member bodies). The work of preparing International Standards is normally carried out through ISO technical committees. Each member body interested in a subject for which a technical committee has been established has the right to be represented on that committee. International organizations, governmental and non-governmental, in liaison with ISO, also take part in the work. ISO collaborates closely with the International Electrotechnical Commission (IEC) on all matters of electrotechnical standardization.

Draft International Standards adopted by the technical committees are circulated to the member bodies for voting. Publication as an International Standard requires approval by at least 75 % of the member bodies casting a vote.

International Standard ISO 13926-1 was prepared by Technical Committee ISO/TC 76, *Transfusion, infusion and injection equipment for medical use*.

This second edition cancels and replaces the first edition (ISO 13926-1:1996), which has been technically revised.

ISO 13926 consists of the following parts, under the general title *Pen systems*:

- Part 1: *Glass cylinders for pen-injectors for medical use*
- Part 2: *Plungers and discs for pen-injectors for medical use*

Annex A of this part of ISO 13926 is for information only.

iTech STANDARD PREVIEW
(standards.iteh.ai)
<https://standards.iteh.ai/catalog/standards/sist/5df08054-9a3a-480a-876d-011d3b4d9e42/iso-13926-1-1998>

© ISO 1998

All rights reserved. Unless otherwise specified, no part of this publication may be reproduced or utilized in any form or by any means, electronic or mechanical, including photocopying and microfilm, without permission in writing from the publisher.

International Organization for Standardization
Case postale 56 • CH-1211 Genève 20 • Switzerland
Internet central@iso.ch
X.400 c=ch; a=400net; p=iso; o=isocs; s=central

Printed in Switzerland

Introduction

The potency, purity, stability and safety of a drug during its manufacture and storage can be strongly affected by the nature and performance of the primary pack.

This part of ISO 13926 deals with glass cylinders used with pen-injectors in accordance with ISO 11608-1. It is applicable to primary packs in direct contact with the drug.

NOTE Aluminium caps for insulin pen-injector systems are covered by ISO 11040-3.

iTeh STANDARD PREVIEW (standards.iteh.ai)

[ISO 13926-1:1998](https://standards.iteh.ai/catalog/standards/sist/5df08054-9a3a-480a-876d-011d3b4d9e42/iso-13926-1-1998)

<https://standards.iteh.ai/catalog/standards/sist/5df08054-9a3a-480a-876d-011d3b4d9e42/iso-13926-1-1998>

iTeh STANDARD PREVIEW
(standards.iteh.ai)

ISO 13926-1:1998

<https://standards.iteh.ai/catalog/standards/sist/5df08054-9a3a-480a-876d-011d3b4d9e42/iso-13926-1-1998>

Pen systems — Part 1: Glass cylinders for pen-injectors for medical use

1 Scope

This part of ISO 13926 specifies the design, dimensions, materials, performance and test methods for glass cylinders used with pen-injectors for medical use.

It applies to the primary container used in direct contact with the drug.

2 Normative references

The following standards contain provisions which, through reference in this text, constitute provisions of this part of ISO 13926. At the time of publication, the editions indicated were valid. All standards are subject to revision, and parties to agreements based on this part of ISO 13926 are encouraged to investigate the possibility of applying the most recent editions of the standards indicated below. Members of IEC and ISO maintain registers of currently valid International Standards.

ISO 720:1985, *Glass – Hydrolytic resistance of glass grains at 121 °C – Method of test and classification.*

ISO 4802-1:1988, *Glassware – Hydrolytic resistance of the interior surfaces of glass containers – Part 1: Determination by titration method and classification.*

ISO 4802-2:1988, *Glassware – Hydrolytic resistance of the interior surfaces of glass containers – Part 2: Determination by flame spectrometry and classification.*

3 Dimensions

The dimensions of the glass cylinders shall be as shown in figure 1 and as given in table 1.

The dimensions of the bore (d_6) shall be maintained for a depth of h_1 .

Variations in the design of the truncated cone are allowed, if at the same time the following conditions are fulfilled:

- the truncated cone of the neck opening has the same height as the neck length (h_1);
- the stated tolerances of the neck opening are maintained;
- the diameter of the neck opening at the inner end may be a maximum of 0,3 mm smaller than at the top.

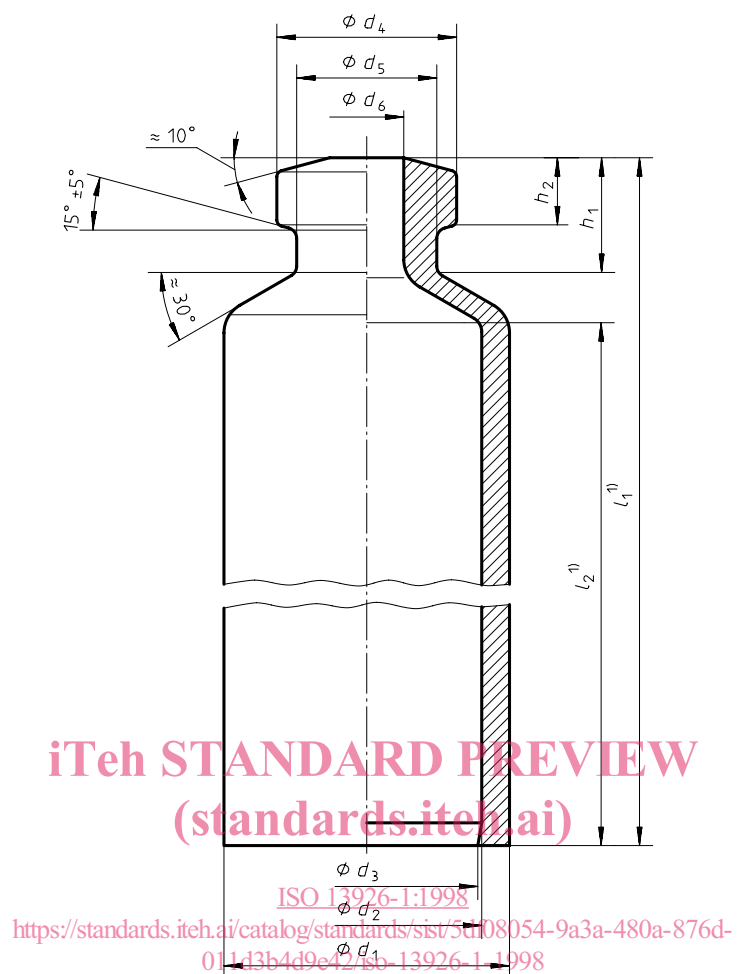

1) Lengths l_1 and l_2 shall be agreed upon between manufacturer and customer

Figure 1 — Configuration of glass cylinders for pen-injectors

Table 1 — Dimensions of glass cylinders for pen-injectors

Dimensions in millimetres

d_1	tol.	d_2	tol.	d_3	d_4	tol.	d_5	tol.	d_6	tol.	h_1	tol.	h_2	tol.
	±		±	min.		±		±		±		±		±
8,65	0,1	6,85	0,1	6,55	7,15	0,2	5,6	0,35	3,15	0,2	5,0	0,20	2,9	0,1
10,85	0,1	8,65	0,1	8,35	7,15	0,2	5,6	0,35	3,15	0,2	5,0	0,20	2,9	0,1
10,95	0,15	9,25	0,1	8,95	7,15	0,2	5,6	0,35	3,15	0,2	5,0	0,20	2,9	0,1
11,60	0,15	9,65	0,1	9,35	7,15	0,2	5,6	0,35	3,15	0,2	5,0	0,20	2,9	0,1
14,00	0,15	12,00	0,15	11,65	9,5	0,2	7,6	0,35	4,5	0,2	5,0	0,50	2,9	0,15
14,45	0,15	11,85	0,15	11,50	9,5	0,2	7,6	0,35	4,5	0,2	5,0	0,50	2,9	0,15
18,25	0,15	16,05	0,15	15,50	9,5	0,2	7,6	0,35	4,5	0,2	5,0	0,50	2,9	0,15

4 Requirements

4.1 Material

Colourless (cl) or amber (br) glass of the hydrolytic resistance grain class in accordance with ISO 720 – HGA 1 shall be used.

It shall correspond to the glass type 1 of the relevant Pharmacopoeia.

A change in the chemical composition of the glass material shall be notified to the user at least nine months in advance.

The glass material used for glass cylinders shall not contain seeds or bubbles to an extent which will interfere with the visual examination of the contents.

4.2 Performance

4.2.1 Sealing surface

Glass cylinders shall have a sealing surface which is flat and free from ripples or undulations.

4.2.2 Hydrolytic resistance

When tested in accordance with ISO 4802-1 or ISO 4802-2, the hydrolytic resistance of the internal surface of the glass cylinder shall comply with the requirements for class HC 1 container glass.

Before conducting the test, the bottom end of the cylinder shall be sealed with a suitable closure element, e.g. silicone rubber.

4.2.3 Annealing quality

If the glass cylinder is annealed, the maximum residual stress shall not produce an optical retardation exceeding 40 nm per millimetre of glass thickness, when the glass cylinder is viewed in a strain viewer.

The optical retardation test method shall be agreed upon between glass manufacturer and customer.

5 Designation

Glass cylinders for pen-injectors for medical use shall be designated by a reference to this part of ISO 13926, followed by the colour of the glass and the nominal diameter d_1 expressed in millimetres.

EXAMPLE A glass cylinder for pen-injectors for medical use, made of colourless (cl) glass tubing of the hydrolytic resistance container class ISO 4802 – HC 1 and a nominal diameter $d_1 = 11,6$ mm, complying with the requirements of this part of ISO 13926 is designated as follows:

Cylinder ISO 13926-1 - cl - 11,6

6 Marking

The package shall be marked with the following information:

- a) the designation of the cylinders;
- b) identifying number (if the cylinder is printed), e.g. lot, batch etc.
- c) the number of cylinders it contains;
- d) the name or symbol of the manufacturer.

iTeh STANDARD PREVIEW
(standards.iteh.ai)

ISO 13926-1:1998

<https://standards.iteh.ai/catalog/standards/sist/5df08054-9a3a-480a-876d-011d3b4d9e42/iso-13926-1-1998>

Annex A **(informative)**

Bibliography

- [1] ISO 11040-3, *Prefilled syringes — Part 3: Aluminium caps for dental local anaesthetic cartridges.*
- [2] ISO 11608-1: –¹⁾, *Pen-injectors for medical use – Part 1: Requirements and test methods.*

iTeh STANDARD PREVIEW
(standards.iteh.ai)

[ISO 13926-1:1998](https://standards.iteh.ai/catalog/standards/sist/5df08054-9a3a-480a-876d-011d3b4d9e42/iso-13926-1-1998)

<https://standards.iteh.ai/catalog/standards/sist/5df08054-9a3a-480a-876d-011d3b4d9e42/iso-13926-1-1998>

1) To be published.