



Designation: D 365 – 01

Standard Guide for Soluble Nitrocellulose Base Solutions¹

This standard is issued under the fixed designation D 365; the number immediately following the designation indicates the year of original adoption or, in the case of revision, the year of last revision. A number in parentheses indicates the year of last reapproval. A superscript epsilon (ϵ) indicates an editorial change since the last revision or reapproval.

1. Scope

1.1 These test methods cover the testing of soluble nitrocellulose base solutions that are made by dispersing various kinds and concentrations of soluble nitrocellulose (cellulose nitrate) in various solvent mixtures.

1.2 The values stated in SI units are to be regarded as the standard. The values given in parentheses are for information only.

1.3 *This standard does not purport to address all of the safety concerns, if any, associated with its use. It is the responsibility of the user of this standard to establish appropriate safety and health practices and determine the applicability of regulatory limitations prior to use.* For specific hazard statements see Section 11.

2. Referenced Documents

2.1 *ASTM Standards:*

D 301 Test Methods for Soluble Cellulose Nitrate²

D 333 Test Methods for Clear and Pigmented Lacquers³

D 1193 Specification for Reagent Water⁴

D 1200 Test Method for Viscosity by Ford Viscosity Cup⁵

E 300 Practice for Sampling Industrial Chemicals⁶

3. Significance and Use

3.1 Since the desired specifications and compositions of soluble nitrocellulose base solutions vary greatly, these methods are used to establish whether limits that shall be as agreed upon between the producer and the user have been met.

4. Sampling

4.1 Select the sampling method from those listed in Practice E 300.

¹ These methods are under the jurisdiction of ASTM Committee D01 on Paint and Related Coatings, Materials, and Applications and are the direct responsibilities of Subcommittee D01.55 on Factory-Applied Coatings on Preformed Products.

Current edition approved May 10, 2001. Published July 2001. Originally published as D 365 – 33. Last previous edition D 365 – 84 (1996)¹.

² *Annual Book of ASTM Standards*, Vol 06.03.

³ *Annual Book of ASTM Standards*, Vol 06.02.

⁴ *Annual Book of ASTM Standards*, Vol 11.01.

⁵ *Annual Book of ASTM Standards*, Vol 06.01.

⁶ *Annual Book of ASTM Standards*, Vol 15.05.

CONSISTENCY (VISCOSITY)

5. Consistency Tests

5.1 *For Consistencies from 3 to 500 s*—Determine the consistency by falling-ball consistency test described in Method D 301 for those solutions having a consistency from 3 to 500 s when tested in that apparatus.

5.2 *For Consistencies Less than 3 s*—Determine the consistency by Test Method D 1200 for those solutions having a consistency of less than 3 s when tested in the falling-ball apparatus referred to in 5.1.

5.3 *For Consistencies over 500 s*—Determine the consistency using the apparatus and procedure described in Sections 6 and 7 for those solutions having a consistency greater than 500 s when tested in the falling-ball apparatus referred to in 5.1.

6. Apparatus

6.1 The consistency test apparatus, shown in Fig. 1, shall consist of the following:

6.1.1 *Glass Tube* (preferably heat-resistant glass),⁷ 50 ± 1.5 mm ($2 \pm \frac{1}{32}$ in.) in inside diameter and 255 mm (10 in.) in length, with marks 177 ± 1 mm ($5 \pm \frac{1}{16}$ in.) apart, the upper one being 75 mm (3 in.) from the top of the tube.

NOTE 1—The steel ball can be removed (in order to leave the same material in the tube for a check run) by removing the lower stopper. However, a small air bubble is usually introduced in this way. It is preferable to invert the tube, removing the guide to get the ball out. It is often necessary to put a few drops of solvent in the guide lip to loosen it from the tube on account of the solution drying at the edge of the tube. When the latter method is used for removing the ball, a larger bubble traverses the tube than when the former method is used, but a large bubble moves sufficiently fast, even in a very viscous solution, to escape at the top in a few minutes, whereas small bubbles take hours to escape.

6.1.2 *Steel Ball*, 15.88 ± 0.02 mm (0.625 ± 0.001 in.) in diameter, and weighing 16.536 ± 0.10 g.

6.1.3 *Aluminum Guide Cone* of light gage aluminum (approximately 0.5 mm (0.02 in.) in thickness) as shown in Fig. 1. The orifice of the guide cone shall be 22 mm ($\frac{7}{8}$ in.) in diameter, the conical portion 25 mm (1 in.) in height, the

⁷ Borosilicate glass is satisfactory for this purpose.

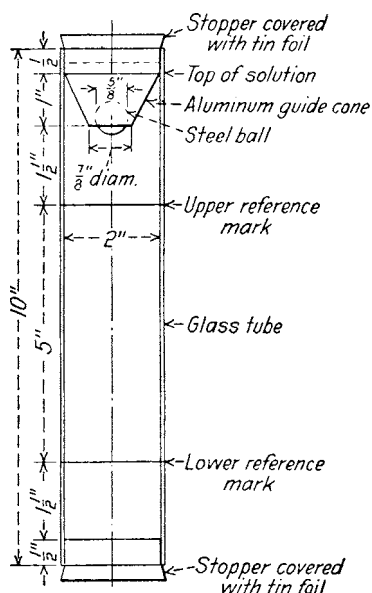

FIG. 1 Apparatus for Consistency (Viscosity) Test of Solutions Having Consistencies over 500 s

NONVOLATILE MATTER

8. Procedure

8.1 Determine the percent of nonvolatile matter in accordance with the procedure described in the Nonvolatile Matter section of Test Methods D 333.

APPEARANCE OF SOLUTION

9. Procedure

9.1 Compare the appearance of the soluble nitrocellulose base solution with a reference standard agreed upon between the purchaser and the seller (both the reference standard and sample solutions shall be thoroughly agitated before making observations) in similar bottles for turbidity, hair, grain, and insoluble matter.

DEPTH OF COLOR

10. Apparatus

10.1 The apparatus used for the preparation of the color standards and for the depth of color determinations shall consist of the following:

10.1.1 *Light*—Source of transmitted light.

NOTE 2—Not absolutely necessary but will increase accuracy and be more convenient.

10.1.2 *Bottles*, three dozen 60 mL (2-oz L) screw-cap, square, glass.

10.1.3 *Flasks*, several, 1-L, volumetric.

10.1.4 *Burets*, two, 50-mL.

10.1.5 *Analytical Balance*.

10.1.6 *Colorimeter*—Dubosq colorimeter (see Note 2).

10.1.7 *Color Glass*—Yellow glass about 25 mm square and 10 mm thick.⁸

11. Reagents and Materials

11.1 *Purity of Reagents*—Reagent grade chemicals shall be used in all tests. Unless otherwise indicated, it is intended that all reagents shall conform to the specifications of the Committee on Analytical Reagents of the American Chemical Society, where such specifications are available.⁹ Other grades may be used, provided it is first ascertained that the reagent is of sufficiently high purity to permit its use without lessening the accuracy of the determination.

11.2 *Purity of Water*—Unless otherwise indicated, references to water shall be understood to mean reagent water as defined by Type III of Specification D 1193.

cylindrical portion 12.7 mm (1/2 in.) in height, and the outside diameter shall be slightly under 50 mm (2 in.) so as to fit snugly into the viscosity tube.

6.1.4 *Stoppers*, made preferably of rubber and covered with tin foil.

7. Procedure

7.1 Fill the tube in any convenient manner whereby bubbles do not form and no appreciable amount of solvent is lost. One method is to immerse the lower end of the open tube in the solution and to apply suction at the upper end of the tube. In this manner the tube can be filled in from 5 to 10 s without the introduction of air bubbles or an appreciable loss of solvent. Close the bottom of the tube with a stopper covered with tin foil. Push the aluminum guide cone slowly into the top of the tube and insert a stopper covered with tin foil into the top of the guide.

7.2 Bring the tube and its contents to a temperature of 25 ± 0.1°C by placing in a suitable bath. Allow at least 30 min for the solution to reach temperature equilibrium. For accurate measurements keep the tube during the determination either in a thermostat or suspended within a considerably larger cylinder of water at the specified temperature.

7.3 Remove the upper stopper only long enough to place the ball in the center of the tube; this can be done conveniently with crucible tongs. The principal value of the guide cone is to retard the ball sufficiently at the start of its fall so that the solution will close over the ball and not leave on the top of the ball a large “trailer bubble.” If the guide is not used a big trailer bubble usually accompanies the ball, retarding its fall and, if the bubble is off center on the ball, pulling the latter away from the center of the tube.

7.4 Measure the time of fall in seconds from the instant the bottom of the ball is level with the upper reference mark on the tube until it reaches the lower mark on the tube.

⁸ The sole source of supply of color glass, signal yellow No. 330, known to the committee at this time is Corning Glass Works, Corning, NY. If you are aware of alternative suppliers, please provide this information to ASTM Headquarters. Your comments will receive careful consideration at a meeting of the responsible technical committee,¹ which you may attend.

⁹ *Reagent Chemicals, American Chemical Society Specifications*, American Chemical Society, Washington, DC. For suggestions on the testing of reagents not listed by the American Chemical Society, see *Analar Standards for Laboratory Chemicals*, BDH Ltd., Poole, Dorset, U.K., and the *United States Pharmacopeia and National Formulary*, U.S. Pharmacopeial Convention, Inc. (USPC), Rockville, MD.