

SLOVENSKI STANDARD
SIST EN 14116:2007**01-september-2007****BUXca Yý U****SIST EN 14116:2003****SIST EN 14116:2003/A1:2005**

Posode za prevoz nevarnih snovi - Digitalni vmesnik za prepoznavalno napravo polnjenja

Tanks for transport of dangerous goods - Digital interface for the product recognition device

iTeh STANDARD PREVIEWTanks für die Beförderung gefährlicher Güter - Digitale Schnittstelle für das Produkterkennungssystem
(standards.itteh.ai)[SIST EN 14116:2007](http://product.iteh.iee/catalog/sist/23066-807-4162007)Citernes destinées au transport de matières dangereuses - Interface numérique du dispositif de reconnaissance de produits
<http://product.iteh.iee/catalog/sist/23066-807-4162007>
<http://standards.iteh.ai/sist-en-14116-2007>**Ta slovenski standard je istoveten z: EN 14116:2007****ICS:**

13.300	Varstvo pred nevarnimi izdelki	Protection against dangerous goods
23.020.20	Posode in vsebniki, montirani na vozila	Vessels and containers mounted on vehicles
35.240.60	Uporabniške rešitve IT v transportu in trgovini	IT applications in transport and trade

SIST EN 14116:2007**en,fr,de**

iTeh STANDARD PREVIEW
(standards.iteh.ai)

SIST EN 14116:2007

<https://standards.iteh.ai/catalog/standards/sist/f42e0c6c-8c7a-4be3-acbe-5007be9f40f6/sist-en-14116-2007>

English Version

Tanks for transport of dangerous goods - Digital interface for the product recognition device

Citernes destinées au transport de matières dangereuses -
Interface numérique du dispositif de reconnaissance de
produits

Tanks für die Beförderung gefährlicher Güter - Digitale
Schnittstelle für das Produkterkennungssystem

This European Standard was approved by CEN on 12 February 2007.

CEN members are bound to comply with the CEN/CENELEC Internal Regulations which stipulate the conditions for giving this European Standard the status of a national standard without any alteration. Up-to-date lists and bibliographical references concerning such national standards may be obtained on application to the CEN Management Centre or to any CEN member.

This European Standard exists in three official versions (English, French, German). A version in any other language made by translation under the responsibility of a CEN member into its own language and notified to the CEN Management Centre has the same status as the official versions.

CEN members are the national standards bodies of Austria, Belgium, Bulgaria, Cyprus, Czech Republic, Denmark, Estonia, Finland, France, Germany, Greece, Hungary, Iceland, Ireland, Italy, Latvia, Lithuania, Luxembourg, Malta, Netherlands, Norway, Poland, Portugal, Romania, Slovakia, Slovenia, Spain, Sweden, Switzerland and United Kingdom.

[SIST EN 14116:2007](https://standards.iteh.ai/catalog/standards/sist/f42e0c6c-8c7a-4be3-acbe-5007be9f40f6/sist-en-14116-2007)

<https://standards.iteh.ai/catalog/standards/sist/f42e0c6c-8c7a-4be3-acbe-5007be9f40f6/sist-en-14116-2007>



EUROPEAN COMMITTEE FOR STANDARDIZATION
COMITÉ EUROPÉEN DE NORMALISATION
EUROPÄISCHES KOMITEE FÜR NORMUNG

Management Centre: rue de Stassart, 36 B-1050 Brussels

Contents

Page

Foreword.....	3
Introduction	4
1 Scope	5
2 Normative references	5
3 Terms, definitions and abbreviations	5
3.1 Terms and definitions.....	5
3.2 Abbreviations	6
4 Functions.....	6
5 Design characteristics.....	8
5.1 General.....	8
5.2 Temperature range	9
5.3 Materials of construction	9
5.4 PRD.....	9
5.5 PID	10
5.6 Contact and insulation resistances	12
5.7 System architecture of MultiPID.....	13
5.8 Electrical design characteristic of MultiPID.....	13
6 Protocol structure.....	17
6.1 Telegram transmission sequences.....	17
6.2 Bit coding	17
6.3 Byte frame.....	18
6.4 Byte sequence in multibyte variables.....	18
6.5 Telegram.....	18
6.6 Message format.....	19
6.7 Message specification.....	20
6.8 Message #5 to #10	24
7 Tests.....	28
7.1 Type test	28
7.2 Production test.....	33
8 Marking	34
9 Installation, operating and maintenance recommendations	34
Annex A (informative) Manufacturer ID	35
Annex B (informative) Patent for hose communication methods	36
Annex C (normative) Calculation algorithm for CRC 16.....	37
Annex D (informative) A-deviations	38

Foreword

This document (EN 14116:2007) has been prepared by Technical Committee CEN/TC 296 “Tanks for transport of dangerous goods”, the secretariat of which is held by AFNOR.

This European Standard shall be given the status of a national standard, either by publication of an identical text or by endorsement, at the latest by October 2007, and conflicting national standards shall be withdrawn at the latest by October 2007.

This document supersedes EN 14116:2003.

This European Standard forms part of a coherent standards program comprising the following European Standards:

EN 13922, *Tanks for transport of dangerous goods — Service equipment for tanks — Overfill prevention systems for liquid fuels.*

EN 13616, *Overfill prevention devices for static tanks for liquid petroleum fuels.*

EN 15207, *Tanks for transport of dangerous goods — Plug/socket connection and supply characteristics for service equipment in hazardous areas with 24 V nominal supply voltage.*

EN 15208, *Tanks for transport of dangerous goods — Sealed parcel delivery systems — Working principles and interface specifications.*

According to the CEN/CENELEC Internal Regulations, the national standards organizations of the following countries are bound to implement this European Standard: Austria, Belgium, Bulgaria, Cyprus, Czech Republic, Denmark, Estonia, Finland, France, Germany, Greece, Hungary, Iceland, Ireland, Italy, Latvia, Lithuania, Luxembourg, Malta, Netherlands, Norway, Poland, Portugal, Romania, Slovakia, Slovenia, Spain, Sweden, Switzerland and United Kingdom.

Introduction

Product recognition, the subject of this European Standard, is the digital interface that allows product data and/or other information to be transferred between transport tanks and other installations.

This European Standard has been extended by the possibility of bidirectional communication and defined messages were added.

Annex B gives more detailed information concerning patent rights for hose communication methods.

iTeh STANDARD PREVIEW (standards.iteh.ai)

[SIST EN 14116:2007](https://standards.iteh.ai/catalog/standards/sist/f42e0c6c-8c7a-4be3-acbe-5007be9f40f6/sist-en-14116-2007)

<https://standards.iteh.ai/catalog/standards/sist/f42e0c6c-8c7a-4be3-acbe-5007be9f40f6/sist-en-14116-2007>

1 Scope

This European Standard covers the digital interface at the product loading and/or discharge coupling which is used for the transfer of product related information and specifies the performance requirements, critical safety aspects and tests to provide compatibility of devices.

This European Standard specifies a digital interface which is suitable for use with liquid fuels.

2 Normative references

The following referenced documents are indispensable for the application of this document. For dated references, only the edition cited applies. For undated references, the latest edition of the referenced document (including any amendments) applies.

EN 50020, *Electrical apparatus for potentially explosive atmospheres — Intrinsic safety "i"*

EN 60079-0, *Electrical apparatus for explosive gas atmospheres — Part 0: General requirements (IEC 60079-0:2004)*

ISO 2859-1, *Sampling procedures for inspection by attributes — Part 1: Sampling schemes indexed by acceptance quality limit (AQL) for lot-by-lot inspection*

ISO 8601, *Data elements and interchange formats — Information interchange — Representation of dates and times*

OIML R 117, *Measuring systems for liquids other than water*

3 Terms, definitions and abbreviations

3.1 Terms and definitions

For the purposes of this document, the following terms and definitions apply.

3.1.1

message

defined data set

3.1.2

telegram

frame that contains at least one standardized message

3.1.3

maximum input voltage (U_i)

according to EN 50020

3.1.4

maximum output voltage (U_0)

according to EN 50020

3.1.5

maximum input current (I_i)

according to EN 50020

3.1.6

maximum output current (I_0)

according to EN 50020

3.1.7

maximum input power (P_i)

according to EN 50020

3.1.8

maximum output power (P_0)

according to EN 50020

3.1.9

maximum internal capacitance (C_i)

according to EN 50020

3.1.10

maximum internal inductance (L_i)

according to EN 50020

3.1.11

Multiple Product Identification Device

MultiPID

electronic device emulating at least one PID, extended by the ability of bi-directional communication

ITEH STANDARD PREVIEW
(standards.iteh.ai)

3.2 Abbreviations

For the purposes of this document, the following abbreviations apply.

SIST EN 14116:2007
<https://standards.iteh.ai/catalog/standards/sist/f42e0c6c-8c7a-4be3-acbe-5007b95f095/sist-en-14116-2007>

ASCII	American Standard Code for Information Interchange
CPDP	Comité Professionnel du Pétrole
CFPP	Cold Filter Plugging Point
ESD	Electro-Static Discharge
LSB	Least Significant Bit
MSB	Most Significant Bit
PID	Product Identification Device
PRD	Product Recognition Device
RON	Research Octane Number

4 Functions

Whenever a physical connection according to Figure 1 or Figure 2 is made, the digital interface enables the transfer of product recognition data to the transport tank. The purpose of this digital interface is to provide the data for the following types of applications:

- a) automatic product identification for each compartment or tank;
- b) cross over prevention.

Bi-directionality may add the ability of communication between the stationary parts and the tank vehicle, e.g. the transfer of data of measured quantities in both directions.

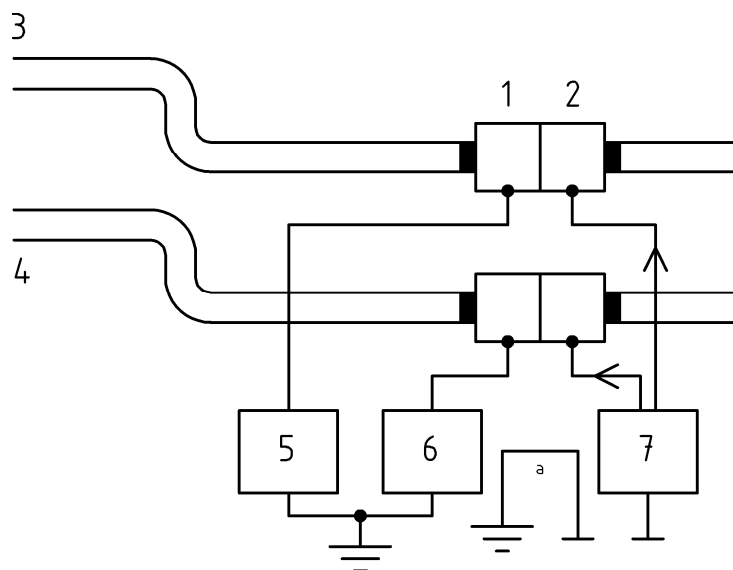

Key

- 1 pipework of loading arm with insulated coupling
- 2 pipework of transport tank with insulated coupling
- 3 vapour line
- 4 product line
- 5 PID, vapour
- 6 PID, product
- 7 PRD
- ^a required, if only one connection is established

iTech STANDARD PREVIEW
(standards.iteh.ai)
SIST EN 14116:2007
<https://standards.iteh.ai/catalog/standards/sist/f42e0c6c-8c7a-4be3-acbe-5007be9f40f6/sist-en-14116-2007>

Figure 1 — Loading

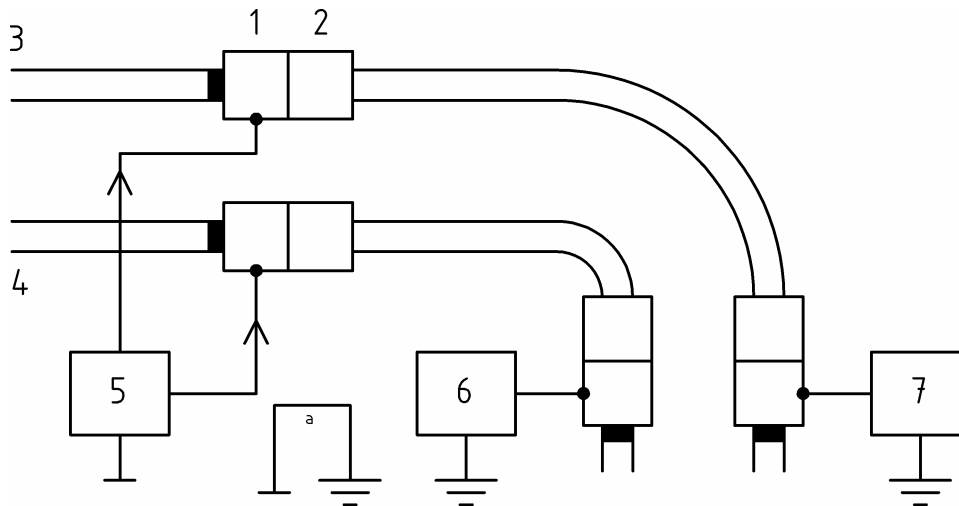

Key

- 1 pipework of transport tank with insulated coupling
- 2 conductive hoses ^b and pipework of stationary tank with insulated couplings
- 3 vapour line
- 4 product line
- 5 PRD
- 6 PID, product
- 7 PID, vapour
- ^a required, if only one connection is established

iTeh STANDARD PREVIEW
(standards.iteh.ai)

SIST EN 14116:2007

^b if the discharge hoses are not conductive then the conductivity of these hoses shall be achieved by other means

Figure 2 — Unloading

PRD supplies an intrinsically safe circuit.

Hazardous area zoning vicinity of coupling and swivels - Zone 1, inside pipework - Zone 0.

5 Design characteristics

5.1 General

The PRD shall be located on the transport tank. The PID shall be connected in series to a current loop with the PRD.

The PRD reads the PID by powering the PID through the hose or loading arm. The PID then sends its data by modulating the supply current, which is sensed by the PRD, see Figure 3.

The PID sends its data, using messages, which are numbered from 1 to 255.

The PID always transmits "message #1". By implementing more messages, it is possible to program the PID with other types of information, see 6.6.

Since the PID modulates the supply current, PIDs shall not be connected in parallel.

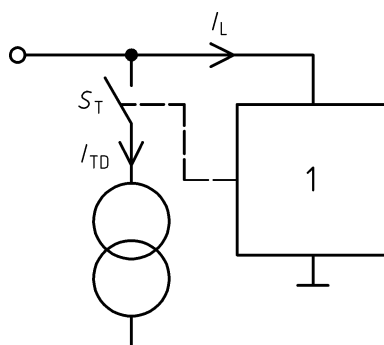

Components

- 1 electronic circuit
- S_T modulating switch
- I_L supply current without modulation
- I_{TD} supply current amplitude

Figure 3 — Basic circuit diagram of PID

5.2 Temperature range

Unless otherwise specified, the operating temperature range shall be -20 °C to $+50\text{ °C}$.

Where the product recognition device is subjected to temperatures outside the specified temperature range all applicable temperature values shall be extended. All other requirements shall remain unchanged.

[SIST EN 14116:2007](https://standards.iteh.ai/catalog/standards/sist/f42e0c6c-8c7a-4be3-acbe-5007be9f40f6/sist-en-14116-2007)

<https://standards.iteh.ai/catalog/standards/sist/f42e0c6c-8c7a-4be3-acbe-5007be9f40f6/sist-en-14116-2007>

5.3 Materials of construction

The manufacturer shall provide with the equipment a full material specification for those parts, which may come into contact with the substances according to Clause 1.

5.4 PRD

The PRD shall provide an intrinsically safe power supply with the values according to Table 1 to the PID.

Table 1 — DC electrical characteristics of PRD

Parameter	Unit	Min.	Nom.	Max.	Ex-values ^a
Open-circuit voltage	V	11	12	15	$U_0 = 15$
Short-circuit current	mA	-	-	300	$I_0 = 300$
Output power	W	-	-	1,1	$P_0 = 1,1$
^a Maximum value to ensure compliance with EN 50020.					

Explosive protection shall be at least EEx ia IIA according to EN 60079-0 and EN 50020.

5.5 PID

5.5.1 General specification

Explosive protection shall be at least EEx ia IIA according to EN 60079-0 and EN 50020.

Table 2 — DC electrical characteristics of PID

Parameter	Symbol	Unit	Min.	Nom.	Max.	Ex-values ^a
Supply voltage	U	V	6	12	15	$U_1 = 15$
Supply current without modulation	I_L	mA	0	5	10	$I_1 = 300$
Supply current at $U_+ < 3$ V	I_{OFF}	mA	-	-	5	-
Maximum input power	P_1	W	-	-	-	= 1,1
Maximum internal capacitance	C_1	nF	-	-	-	= 600
Maximum internal inductance	L_1	μ H	-	-	-	= 10

^a Maximum value to ensure compliance with EN 50020.

Table 3 — AC electrical characteristics of PID

Parameter	Symbol	Unit	Min.	Nom.	Max.
Supply current amplitude	I_{TD}	mA	10	15	20
Clock rate	f_{TC}	Hz	4 800	4 880	4 960
Duty cycle	cd_T	%	40	50	60
Rise time of output signal	t_{Tr}	μ s	0	-	30
Fall time of output signal	t_{Tf}	μ s	0	-	30
Transmission delay after power on	t_{Tds}	ms	0	-	0,9

The timing diagram of PID is shown in Figure 4.

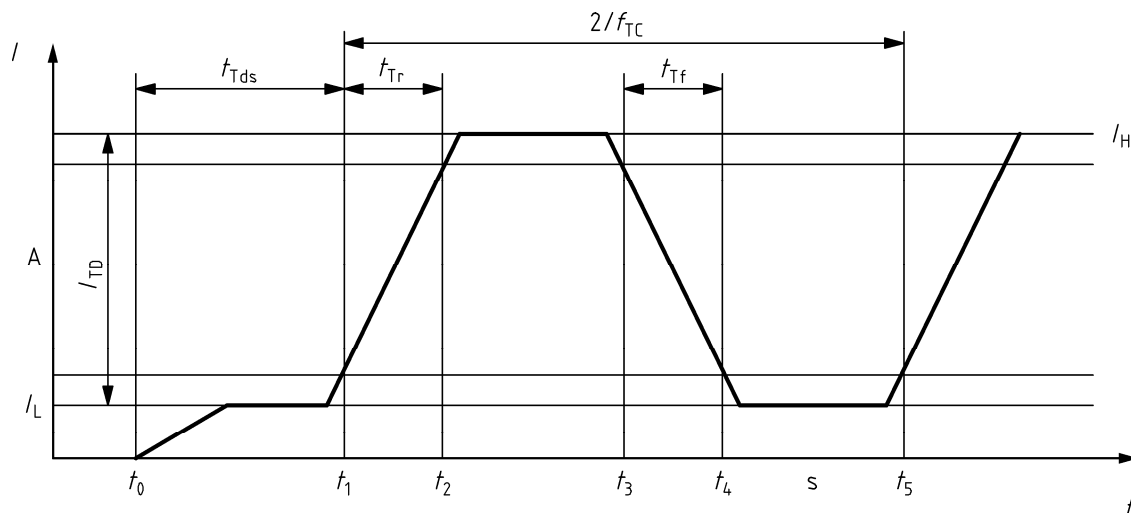

Key

$f_{TC} = 2 \times \text{baud rate } (f_{bit})$

I_H supply current with modulation

I_L supply current without modulation

$t_0 = t$ at power ON

$t_1, t_4, t_5 = t$ at $i = I_L + 10\% I_{TD}$

$t_2, t_3 = t$ at $i = I_L + 90\% I_{TD}$

I_{TD} supply current amplitude

t_{Tds} transmission delay after power on

t_{Tf} fall time of output signal

t_{Tr} rise time of output signal

iTeH STANDARD PREVIEW
(standards.iteh.ai)

Figure 4 — Timing diagram of PID

5.5.2 Diode and ESD protection

SIST EN 14116:2007

<https://standards.iteh.ai/catalog/standards/sist/f42e0c6c-8c7a-4be3-acbe-5007b98707c6/sist-en-14116-2007>

To maintain ESD protection, a resistor has to be implemented into the PID, see Figure 5 and Table 4.

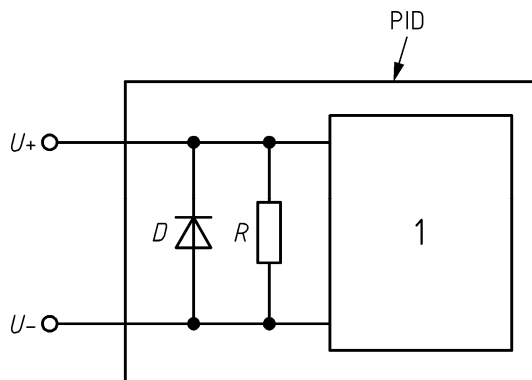

Components

1 electronic circuit

D diode

R ESD resistor

Figure 5 — PID schematic wiring diagram