

---

---

**Reaction to fire tests for floorings —**

**Part 2:**

**Determination of flame spread at a heat  
flux level of 25 kW/m<sup>2</sup>**

*Essais de réaction au feu des revêtements de sol —  
Partie 2: Détermination de la propagation de flamme à un niveau de  
flux énergétique de 25 kW/m<sup>2</sup>*

ISO 9239-2:2002

<https://standards.iteh.ai/catalog/standards/sist/fc107369-5dbe-47d4-b0d8-aa6868c06ffa/iso-9239-2-2002>



**PDF disclaimer**

This PDF file may contain embedded typefaces. In accordance with Adobe's licensing policy, this file may be printed or viewed but shall not be edited unless the typefaces which are embedded are licensed to and installed on the computer performing the editing. In downloading this file, parties accept therein the responsibility of not infringing Adobe's licensing policy. The ISO Central Secretariat accepts no liability in this area.

Adobe is a trademark of Adobe Systems Incorporated.

Details of the software products used to create this PDF file can be found in the General Info relative to the file; the PDF-creation parameters were optimized for printing. Every care has been taken to ensure that the file is suitable for use by ISO member bodies. In the unlikely event that a problem relating to it is found, please inform the Central Secretariat at the address given below.

**iTeh STANDARD PREVIEW**  
**(standards.iteh.ai)**

ISO 9239-2:2002

<https://standards.iteh.ai/catalog/standards/sist/fc107369-5dbe-47d4-b0d8-aa6868c06ffa/iso-9239-2-2002>

© ISO 2002

All rights reserved. Unless otherwise specified, no part of this publication may be reproduced or utilized in any form or by any means, electronic or mechanical, including photocopying and microfilm, without permission in writing from either ISO at the address below or ISO's member body in the country of the requester.

ISO copyright office  
Case postale 56 • CH-1211 Geneva 20  
Tel. + 41 22 749 01 11  
Fax + 41 22 749 09 47  
E-mail [copyright@iso.org](mailto:copyright@iso.org)  
Web [www.iso.org](http://www.iso.org)

Published in Switzerland

## Contents

Page

|  |    |
|--|----|
| Foreword .....   | iv |
| Introduction .....                                       | v  |
| 1 Scope .....  | 1  |
| 2 Normative references .....                             | 1  |
| 3 Terms and definitions .....                            | 1  |
| 4 Apparatus .....  | 2  |
| 5 Test specimen .....                                    | 14 |
| 6 Conditioning .....                                     | 14 |
| 7 Calibration procedure .....                            | 14 |
| 8 Standard test procedure .....                          | 16 |
| 9 Expression of results .....                            | 17 |
| 10 Precision .....                                       | 17 |
| 11 Test report .....                                     | 17 |
| Annex A (informative) Gas and air supplies .....         | 18 |
| Annex B (informative) Precision of the test method ..... | 19 |
| Bibliography .....                                       | 20 |

iTeH STANDARD PREVIEW  
 (standards.iteh.ai)  
 ISO 9239-2:2002  
<https://standards.iteh.ai/catalog/standards/sist/1c107369-5dbe-47d4-b0d8-aa6868c06ffa/iso-9239-2-2002>

## Foreword

ISO (the International Organization for Standardization) is a worldwide federation of national standards bodies (ISO member bodies). The work of preparing International Standards is normally carried out through ISO technical committees. Each member body interested in a subject for which a technical committee has been established has the right to be represented on that committee. International organizations, governmental and non-governmental, in liaison with ISO, also take part in the work. ISO collaborates closely with the International Electrotechnical Commission (IEC) on all matters of electrotechnical standardization.

International Standards are drafted in accordance with the rules given in the ISO/IEC Directives, Part 2.

The main task of technical committees is to prepare International Standards. Draft International Standards adopted by the technical committees are circulated to the member bodies for voting. Publication as an International Standard requires approval by at least 75 % of the member bodies casting a vote.

Attention is drawn to the possibility that some of the elements of this document may be the subject of patent rights. ISO shall not be held responsible for identifying any or all such patent rights.

ISO 9239-2 was prepared by Technical Committee ISO/TC 92, *Fire safety*, Subcommittee SC 1, *Fire initiation and growth*.

ISO 9239 consists of the following parts, under the general title *Reaction to fire tests for floorings*:

- *Part 1: Determination of the burning behaviour using a radiant heat source*
- *Part 2: Determination of flame spread at a heat flux level of 25 kW/m<sup>2</sup>*

**iTeh STANDARD PREVIEW**  
**(standards.iteh.ai)**  
ISO 9239-2:2002  
<https://standards.iteh.ai/catalog/standards/sist/107369-5dbe-47d4-b0d8-aa6868c06ffa/iso-9239-2-2002>

## Introduction

ISO/TR 5658-1 describes the development of standard tests for flame spread and explains the theory of flame spread, including horizontal flame spread over floorings.

Floorings are not readily involved in fires but if fire develops due to other contents of a building burning, then floorings may ignite and it is necessary to be able to determine whether the flooring will propagate flames.

This part of ISO 9239 provides a simple method by which horizontal surface spread of flame on a horizontal specimen can be determined for comparative purposes.

Fire is a complex phenomenon: its behaviour and its effects depend upon a number of interrelated factors. The behaviour of materials and products depends upon the characteristics of the fire, the method of the use of the materials and the environment in which they are exposed. The philosophy of "reaction to fire" tests is explained in ISO/TR 3814.

A test such as is specified in this part of ISO 9239 deals only with a simple representation of a particular aspect of the potential fire situation typified by a radiant heat source and flame; it cannot alone provide any direct guidance on behaviour or safety in fire.

### CAUTION:

## iTeh STANDARD PREVIEW

The possibility of a gas-air fuel explosion in the test chamber should be recognized. Suitable safeguards consistent with sound engineering practice should be installed in the panel fuel supply system. These should include at least the following:

- a gas feed cut-off which is immediately activated when air and/or gas supply fail;
- a temperature sensor or a flame detection unit directed at the panel surface that stops fuel flow when the panel flame goes out.

Attention is drawn to the possibility that toxic or harmful gases may be produced during exposure of the specimens. In view of the potential hazard from products of combustion, the exhaust system shall be designed and operated so that the laboratory environment is protected from smoke and gas. The operator shall be instructed to minimize his exposure to combustion products by following sound safety practice, e.g., ensuring that the exhaust system is working properly, wearing appropriate clothing etc. The operator should also be aware that the walls and fittings of the test chamber become hot during the test and gloves should be worn to avoid burns.

**iTeh STANDARD PREVIEW**  
**(standards.iteh.ai)**

ISO 9239-2:2002

<https://standards.iteh.ai/catalog/standards/sist/fc107369-5dbe-47d4-b0d8-aa6868c06ffa/iso-9239-2-2002>

# Reaction to fire tests for floorings —

## Part 2:

## Determination of flame spread at a heat flux level of 25 kW/m<sup>2</sup>

### 1 Scope

This part of ISO 9239 specifies a method for assessing the burning behaviour of horizontally mounted flooring systems exposed to a heat flux gradient in a test chamber, when ignited with pilot flames. The radiant heat gradient is higher than the one described in ISO 9239-1 in order to simulate conditions in a corridor adjacent to a room containing a fully developed fire (post-flashover).

This method is applicable to all types of flooring such as textile carpets, cork, wood, rubber and plastic coverings as well as coatings. Results obtained by this method reflect the performance of the flooring, including any substrate if used. Modifications of the backing, bonding to a substrate, underlay, or other changes of the flooring may affect test results.

This part of ISO 9239 is applicable to the measurement and description of the properties of floorings in response to heat and flame under controlled laboratory conditions. It should not be used alone to describe or appraise the fire hazard or fire risk of floorings under actual fire conditions.

<https://standards.iteh.ai/catalog/standards/sist/fc107369-5dbe-47d4-b0d8-aa6868c06ffa/iso-9239-2-2002>

### 2 Normative references

The following referenced documents are indispensable for the application of this document. For dated references, only the edition cited applies. For undated references, the latest edition of the referenced document (including any amendments) applies.

ISO 13943:2000, *Fire safety — Vocabulary*

ISO/TR 14697:1997, *Fire tests — Guidance on the choice of substrates for building products*

### 3 Terms and definitions

For the purposes of this document, the definitions given in ISO 13943, together with the following apply.

#### 3.1

##### heat flux

incident heat energy (both radiant and convective) per unit area (kW/m<sup>2</sup>)

#### 3.2

##### critical heat flux at extinguishment

##### CHF

incident heat flux at the surface of a specimen at the point where the flame ceases to advance and may subsequently go out

**3.3**  
**heat flux at X min**  
**HF-X**

total heat flux received by the specimen at the most distant spread of flame position after X min of testing

**3.4**  
**flux profile**  
curve relating radiant flux on the specimen plane to distance from the zero point

NOTE The zero point of the radiant flux profile is specified as the inner edge of the hottest side of the specimen holder.

**3.5**  
**flashing**  
existence of flame on or over the surface of the specimen for periods of less than 1 s

**3.6**  
**transitory flaming**  
existence of flame on or over the surface of the specimen for periods of between 1 s and 4 s

**3.7**  
**sustained flaming**  
existence of flame on or over the surface of the specimen for periods of more than 4 s

**3.8**  
**flame front**  
furthest extent of flame spread of a sustained flame along the length of the test specimen within a given time

**3.9**  
**flooring**  
upper layer of a floor, comprising any surface finish, with or without attached backing and with any accompanying underlay, interlayment and adhesive

**3.10**  
**substrate**  
floor on which the flooring is mounted or the material that represents the floor

## 4 Apparatus

### 4.1 Test chamber

#### 4.1.1 Location of chamber

The test apparatus shall be placed in a room with a clearance of at least 0,4 m to the walls and the ceiling.

#### 4.1.2 Construction of chamber

The test chamber shall have the dimensions shown in Figures 1 to 4. The chamber shall be made of calcium silicate boards of  $(13 \pm 1)$  mm thickness and  $650 \text{ kg/m}^3$  nominal density, with a tightly fitting panel of fire-resistant glass of dimensions  $(110 \pm 10) \text{ mm} \times (1\ 100 \pm 100) \text{ mm}$  situated at the front, so that the whole length of the specimen can be observed during the test. The chamber may have an outside metal cladding. Below this observation window, a tightly closing door shall be provided through which the test specimen platform can be moved in and out.



Dimensions in millimetres

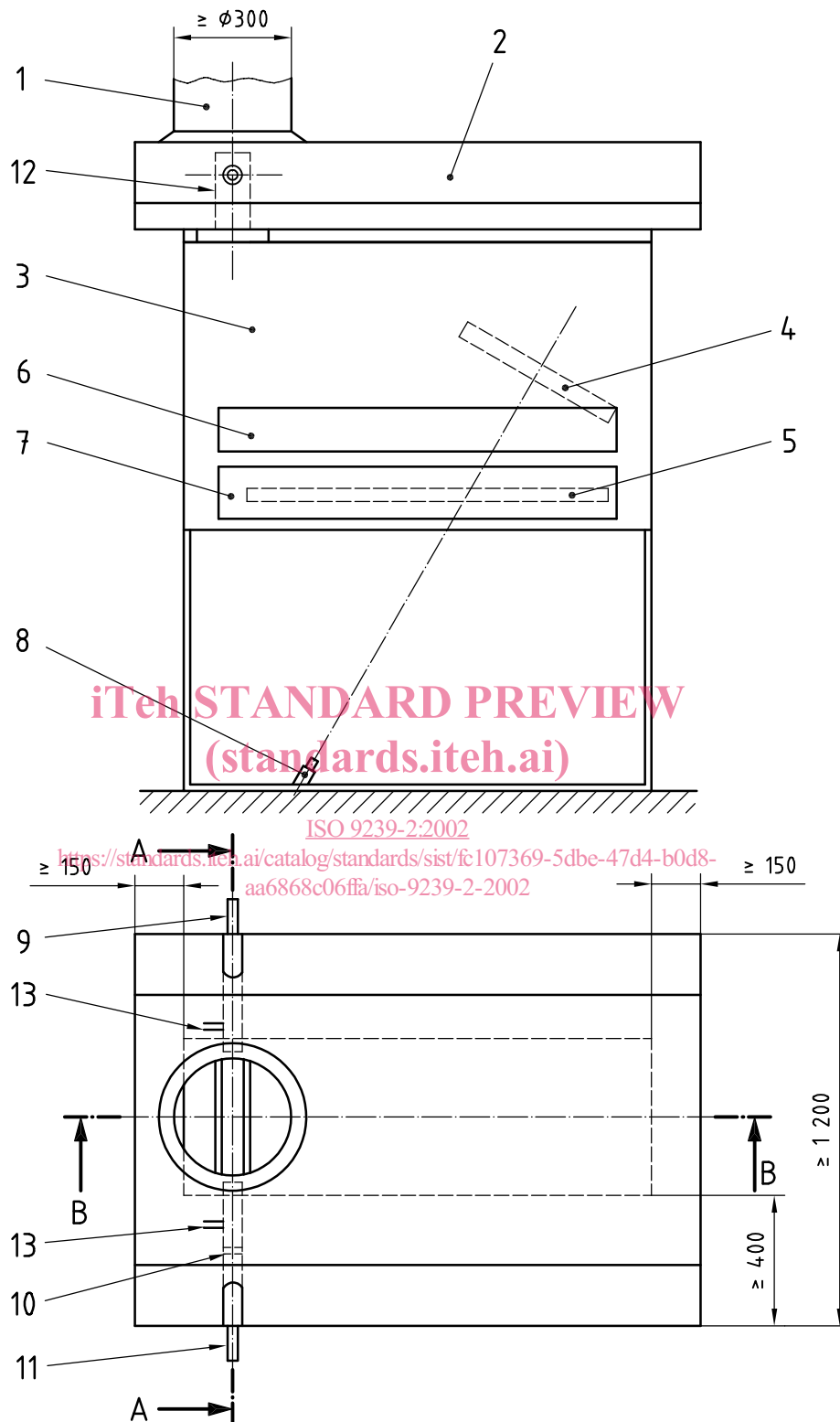

iTeh STANDARD PREVIEW  
(standards.iteh.ai)

ISO 9239-2:2002

<https://standards.iteh.ai/catalog/standards/sist/fc107369-5dbe-47d4-b0d8-aa6868c06ffa/iso-9239-2-2002>

**Key**

- |                                 |  |                                 |
|---------------------------------|--|---------------------------------|
| 1 exhaust duct                  | 6 observation window                         | 11 light receiver (optional)    |
| 2 exhaust hood                  | 7 door for insertion and removal of specimen | 12 exhaust stack                |
| 3 test chamber                  | 8 pyrometer                                  | 13 tubes for purging air supply |
| 4 gas-fired radiant panel       | 9 illumination unit (optional)               |                                 |
| 5 specimen holder with specimen | 10 slot for calibration filters              |                                 |

**Figure 1 — Side and plan view of test equipment**

Dimensions in millimetres

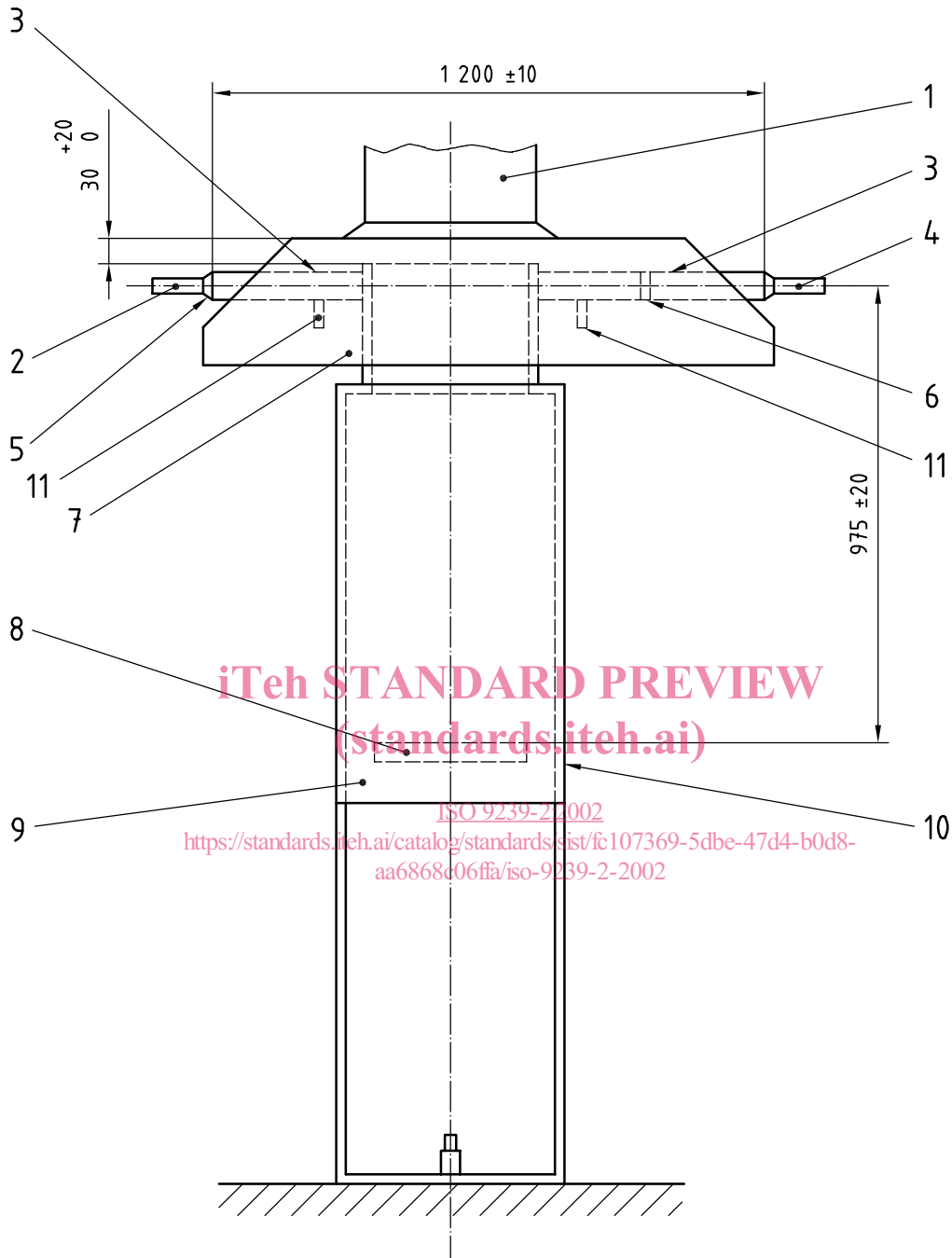

iTeh STANDARD PREVIEW  
 (standards.iteh.ai)  
 ISO 9239-2:2002  
<https://standards.iteh.ai/catalog/standards/sist/fc107369-5dbe-47d4-b0d8-aa6868d06ffa/iso-9239-2-2002>

**Key**

- |   |   |
|---|---|
| 1 exhaust duct                                      | 7 exhaust hood                                |
| 2 illumination unit (optional)                      | 8 specimen holder with specimen               |
| 3 steel tubes for light measuring system (optional) | 9 test chamber                                |
| 4 light receiver (optional)                         | 10 door for insertion and removal of specimen |
| 5 collar or rubber rings                            | 11 tubes for purging air supply               |
| 6 slot for calibration filters                      |   |

**Figure 2 — End view of test equipment**

