

**01-maj-2009**

5 YfcbUj h\_U'!'?cbY\_lcf^žYY\_hf] b]žc\_fc[ `]žnUý ]hYb`\_cbhU\_hž\ ]fUgdc^\_Un  
bUj c^Ya žghU bUXYcj bUHy/a dYfUhi fU%+) š7 'U]'&\$\$ š7 '!\$% "XY.'G`YdUXcnU!  
GHUbXUfX'nUdfc]nj cX

Aerospace series - Connectors, electrical, circular, scoop-proof, triple start threaded coupling, operating temperature 175 °C or 200 °C continuous - Part 013: Dummy receptacle - Product standard

**ITeH STANDARD PREVIEW**

Luft- und Raumfahrt - Elektrische Rundsteckverbinder, kontaktgeschützt, dreigängige Gewinde-Schnellkupplung, Betriebstemperatur 175 °C oder 200 °C konstant - Teil 013: Blinddose - Produktnorm

[SIST EN 3645-013:2009](https://standards.iteh.ai/catalog/standards/sist/58f08eb0-5728-4949-bb23-)

<https://standards.iteh.ai/catalog/standards/sist/58f08eb0-5728-4949-bb23->

Série aérospatiale - Connecteurs électriques circulaires à contacts protégés, à accouplement par filetage à pas rapide à trois filets, températures d'utilisation 175 °C ou 200 °C continu - Partie 013 : Embase de repos - Norme de produit

**Ta slovenski standard je istoveten z: EN 3645-013:2007**

**ICS:**

49.060

Š^cp \ æš Á^•[ |b \ æ  
^|\ dã } æ ] !^ { æš Á ã c^ { ã

Aerospace electric  
equipment and systems

**SIST EN 3645-013:2009****en,de**

**iTeh STANDARD PREVIEW**  
**(standards.iteh.ai)**

SIST EN 3645-013:2009

<https://standards.iteh.ai/catalog/standards/sist/58f08eb0-5728-4949-bb23-210ebf6a0c64/sist-en-3645-013-2009>

EUROPEAN STANDARD

**EN 3645-013**

NORME EUROPÉENNE

EUROPÄISCHE NORM

April 2007

ICS 49.060

English Version

**Aerospace series - Connectors, electrical, circular, scoop-proof,  
triple start threaded coupling, operating temperature 175 °C or  
200 °C continuous - Part 013: Dummy receptacle - Product  
standard**

Série aérospatiale - Connecteurs électriques circulaires à contacts protégés, à accouplement par filetage à pas rapide à trois filets, températures d'utilisation 175 °C ou 200 °C continu - Partie 013 : Embase de repos - Norme de produit

Luft- und Raumfahrt - Elektrische Rundsteckverbinder, kontaktgeschützt, Drei-gangige Gewinde-Schnellkupplung, Dauerbetriebstemperaturen 175 °C oder 200 °C - Teil 013: Blinddose - Produktnorm

This European Standard was approved by CEN on 28 September 2006.

CEN members are bound to comply with the CEN/CENELEC Internal Regulations which stipulate the conditions for giving this European Standard the status of a national standard without any alteration. Up-to-date lists and bibliographical references concerning such national standards may be obtained on application to the CEN Management Centre or to any CEN member.

This European Standard exists in three official versions (English, French, German). A version in any other language made by translation under the responsibility of a CEN member into its own language and notified to the CEN Management Centre has the same status as the official versions.

<https://standards.iteh.ai/catalog/standards/sist/58f08eb0-5728-4949-bb23-32d18f8a1644/en-3645-013:2006>

CEN members are the national standards bodies of Austria, Belgium, Bulgaria, Cyprus, Czech Republic, Denmark, Estonia, Finland, France, Germany, Greece, Hungary, Iceland, Ireland, Italy, Latvia, Lithuania, Luxembourg, Malta, Netherlands, Norway, Poland, Portugal, Romania, Slovakia, Slovenia, Spain, Sweden, Switzerland and United Kingdom.



EUROPEAN COMMITTEE FOR STANDARDIZATION  
COMITÉ EUROPÉEN DE NORMALISATION  
EUROPÄISCHES KOMITEE FÜR NORMUNG

**Management Centre: rue de Stassart, 36 B-1050 Brussels**

**Contents**

Page

|                                  |   |
|----------------------------------|---|
| Foreword.....                    | 3 |
| 1 Scope .....                    | 4 |
| 2 Normative references .....     | 4 |
| 3 Terms and definitions .....    | 4 |
| 4 Required characteristics ..... | 5 |
| 5 Designation .....              | 8 |
| 6 Marking .....                  | 8 |
| 7 Technical specification .....  | 8 |

**iTeh STANDARD PREVIEW**  
**(standards.iteh.ai)**

[SIST EN 3645-013:2009](#)

<https://standards.iteh.ai/catalog/standards/sist/58f08eb0-5728-4949-bb23-210ebf6a0c64/sist-en-3645-013-2009>

## Foreword

This document (EN 3645-013:2007) has been prepared by the Aerospace and Defence Industries Association of Europe - Standardization (ASD-STAN).

After enquiries and votes carried out in accordance with the rules of this Association, this Standard has received the approval of the National Associations and the Official Services of the member countries of ASD, prior to its presentation to CEN.

This European Standard shall be given the status of a national standard, either by publication of an identical text or by endorsement, at the latest by October 2007, and conflicting national standards shall be withdrawn at the latest by October 2007.

Attention is drawn to the possibility that some of the elements of this document may be the subject of patent rights. CEN [and/or CENELEC] shall not be held responsible for identifying any or all such patent rights.

According to the CEN/CENELEC Internal Regulations, the national standards organizations of the following countries are bound to implement this European Standard: Austria, Belgium, Bulgaria, Cyprus, Czech Republic, Denmark, Estonia, Finland, France, Germany, Greece, Hungary, Iceland, Ireland, Italy, Latvia, Lithuania, Luxembourg, Malta, Netherlands, Norway, Poland, Portugal, Romania, Slovakia, Slovenia, Spain, Sweden, Switzerland and the United Kingdom.

**ITEH STANDARD PREVIEW**  
**(standards.iteh.ai)**

[SIST EN 3645-013:2009](https://standards.iteh.ai/catalog/standards/sist/58f08eb0-5728-4949-bb23-210ebf6a0c64/sist-en-3645-013-2009)

<https://standards.iteh.ai/catalog/standards/sist/58f08eb0-5728-4949-bb23-210ebf6a0c64/sist-en-3645-013-2009>

**EN 3645-013:2007 (E)****1 Scope**

This standard specifies the characteristics of dummy receptacles in the family of circular, electrical connectors, with triple start threaded coupling.

It applies to models in Table 3.

For plugs and protective covers, see EN 3645-006, EN 3645-008, EN 3645-011 or EN 3645-012 respectively.

These receptacles are derived from and interchangeable with those in specification MIL-DTL-38999/22.

**2 Normative references**

The following referenced documents are indispensable for the application of this document. For dated references, only the edition cited applies. For undated references, the latest edition of the referenced document (including any amendments) applies.

EN 3645-001, *Aerospace series — Connectors, electrical, circular, scoop-proof, triple start threaded coupling, operating temperature 175 °C or 200 °C continuous — Part 001: Technical specification.*

EN 3645-002, *Aerospace series — Connectors, electrical, circular, scoop-proof, triple start threaded coupling, operating temperature 175 °C or 200 °C continuous — Part 002: Specification of performance and contact arrangements.*

EN 3645-006, *Aerospace series — Connectors, electrical, circular, scoop-proof, triple start threaded coupling, operating temperature 175 °C or 200 °C continuous — Part 006: Protective cover for receptacle — Product standard.*

EN 3645-008, *Aerospace series — Connectors, electrical, circular, scoop-proof, triple start threaded coupling, operating temperature 175 °C or 200 °C continuous — Part 008: Non release plug with grounding ring — Product standard.*

EN 3645-011, *Aerospace series — Connectors, electrical, circular, scoop-proof, triple start threaded coupling, operating temperature 175 °C or 200 °C continuous — Part 011: Lanyard release plug with grounding fingers — Type 1 — Product standard.*

EN 3645-012, *Aerospace series — Connectors, electrical, circular, scoop-proof, triple start threaded coupling, operating temperature 175 °C or 200 °C continuous — Part 012: Lanyard release plug with grounding fingers — Type 2 — Product standard.*

MIL-DTL-38999/22, *Connectors, electrical, circular, receptacle, threaded, dummy stowage, series III, metric.*<sup>1)</sup>

**3 Terms and definitions**

For the purposes of this document, the terms and definitions given in EN 3645-001 apply.

---

1) Published by: Department of Defense (DOD), The Pentagon, Washington D.C. 20301 USA.

## 4 Required characteristics

### 4.1 Dimensions and mass

See Figure 1 and Table 1.

Dimensions and tolerances are in millimetres.

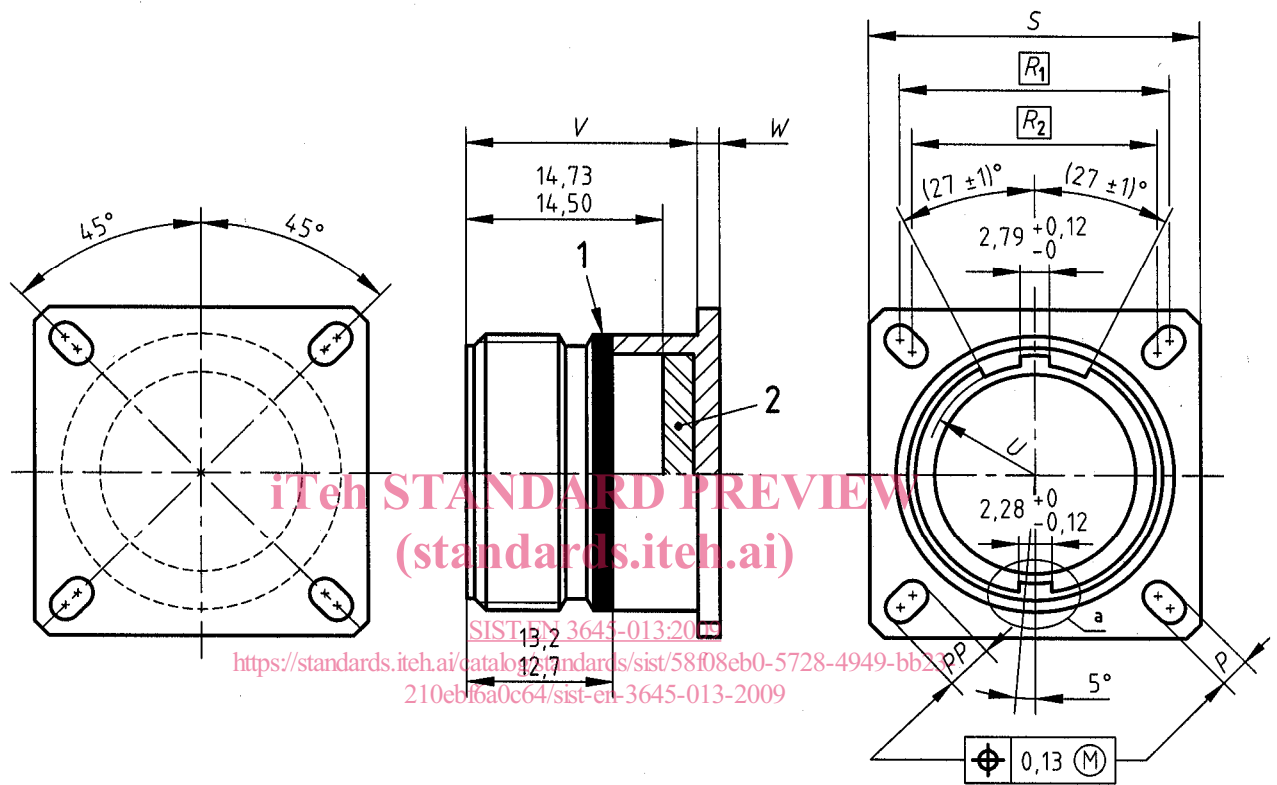

Figure 1

Table 1

| Shell size | $P$<br>+0,2<br>0 | $PP$<br>+0,2<br>0 | $R_1$ | $R_2$ | $S$<br>$\pm 0,30$ | $V$<br>+1,4<br>0 | $W$          | $U$          | Mass<br>g<br>max. |            |    |
|------------|------------------|-------------------|-------|-------|-------------------|------------------|--------------|--------------|-------------------|------------|----|
|            |                  |                   |       |       |                   |                  |              |              | Models<br>F and W | Model<br>K |    |
| 09         | 3,25             | 4,93              | 5,49  | 18,26 | 15,09             | 23,80            | 19,50        | 2,80<br>2,20 | a                 | 7          | 20 |
| 11         |                  |                   | 20,62 | 18,26 | 26,20             | 7,24             |              |              | 11                | 32         |    |
| 13         |                  |                   | 23,01 | 20,62 | 28,60             | 8,66             |              |              | 15                | 44         |    |
| 15         |                  |                   | 24,61 | 23,01 | 31,00             | 10,24            |              |              | 18                | 52         |    |
| 17         |                  |                   | 26,97 | 24,61 | 33,30             | 11,84            |              |              | 22                | 64         |    |
| 19         |                  |                   | 29,35 | 26,97 | 36,50             | 13,16            |              |              | 26                | 75         |    |
| 21         |                  |                   | 31,75 | 29,36 | 39,70             | 14,76            |              |              | 30                | 87         |    |
| 23         | 3,91             | 6,15              | 34,93 | 31,75 | 42,90             | 18,70            | 3,50<br>2,90 | 16,33        | 33                | 96         |    |
| 25         |                  |                   | 38,10 | 34,93 | 46,00             |                  |              | 17,93        | 36                | 104        |    |

<sup>a</sup>  $U$  size 09 =  $5,61 \begin{smallmatrix} 0 \\ -0,06 \end{smallmatrix}$

**iTeh STANDARD PREVIEW**  
(standards.iteh.ai)

#### 4.2 Materials and surface treatment

[SIST EN 3645-013:2009](#)

See Table 3.

<https://standards.iteh.ai/catalog/standards/sist/58f08eb0-5728-4949-bb23-210ebf6a0c64/sist-en-3645-013-2009>

#### 4.3 Recommended panel cut-out

See Figure 2 and Table 2.

Dimensions and tolerances are in millimetres.



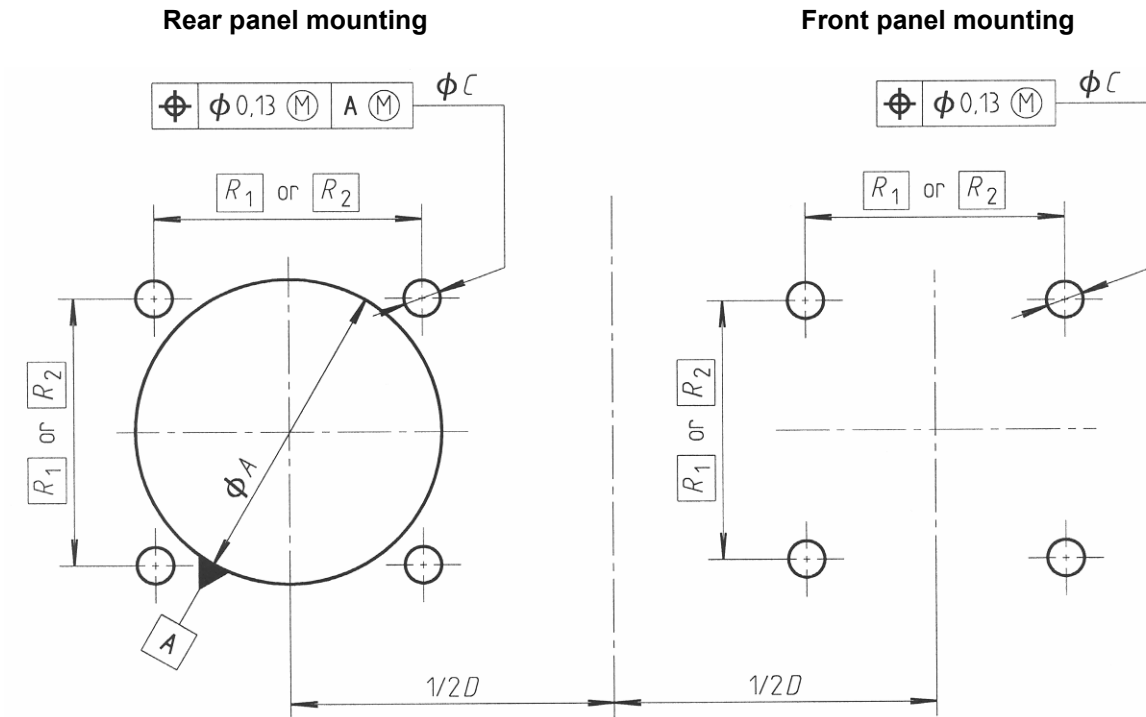

Figure 2  
Table 2  
iTeh STANDARD PREVIEW  
(standards.iteh.ai)

| Shell size | $A$<br>min | $C$<br>$\pm 0,13$ | $D$<br>min | $R_1$ | $R_2$ |
|------------|------------|-------------------|------------|-------|-------|
| 09         | 16,66      | 3,25              | 31,80      | 18,26 | 15,09 |
| 11         | 20,22      |                   | 35,00      | 20,62 | 18,26 |
| 13         | 23,42      |                   | 39,40      | 23,01 | 20,62 |
| 15         | 26,59      |                   | 42,50      | 24,61 | 23,01 |
| 17         | 30,96      |                   | 45,70      | 26,97 | 24,61 |
| 19         | 32,94      |                   | 48,50      | 29,36 | 26,97 |
| 21         | 36,12      |                   | 51,70      | 31,75 | 29,36 |
| 23         | 39,29      | 3,81              | 54,90      | 34,93 | 31,75 |
| 25         | 42,47      |                   | 58,00      | 38,10 | 34,93 |

#### 4.4 Electrical, mechanical and climatic characteristics

See EN 3645-002.