**Protective clothing for users of hand-held
chain-saws —**

Part 5:
**Test methods and performance
requirements for protective gaiters**

iTeh STANDARD PREVIEW

*Vêtements de protection pour utilisateurs de scies à chaîne tenues à la
main —*

*Partie 5: Méthodes d'essai et exigences de performance pour guêtres de
protection*

<https://standards.iteh.ai/catalog/standards/sist/0130d69e-872b-49b7-8ea1-ccc668fa0937/iso-11393-5-2001>



PDF disclaimer

This PDF file may contain embedded typefaces. In accordance with Adobe's licensing policy, this file may be printed or viewed but shall not be edited unless the typefaces which are embedded are licensed to and installed on the computer performing the editing. In downloading this file, parties accept therein the responsibility of not infringing Adobe's licensing policy. The ISO Central Secretariat accepts no liability in this area.

Adobe is a trademark of Adobe Systems Incorporated.

Details of the software products used to create this PDF file can be found in the General Info relative to the file; the PDF-creation parameters were optimized for printing. Every care has been taken to ensure that the file is suitable for use by ISO member bodies. In the unlikely event that a problem relating to it is found, please inform the Central Secretariat at the address given below.

iTeh STANDARD PREVIEW
(standards.iteh.ai)

[ISO 11393-5:2001](https://standards.iteh.ai/catalog/standards/sist/0130d69e-872b-49b7-8ea1-ccc668fa0937/iso-11393-5-2001)

<https://standards.iteh.ai/catalog/standards/sist/0130d69e-872b-49b7-8ea1-ccc668fa0937/iso-11393-5-2001>

© ISO 2001

All rights reserved. Unless otherwise specified, no part of this publication may be reproduced or utilized in any form or by any means, electronic or mechanical, including photocopying and microfilm, without permission in writing from either ISO at the address below or ISO's member body in the country of the requester.

ISO copyright office
Case postale 56 • CH-1211 Geneva 20
Tel. + 41 22 749 01 11
Fax + 41 22 749 09 47
E-mail copyright@iso.ch
Web www.iso.ch

Printed in Switzerland

Contents

	Page
1 Scope	1
2 Normative references	1
3 Terms and definitions	1
4 Requirements	2
5 Pretreatment	3
6 Testing of the resistance to the chain-saw	4
7 Testing the strength of the underfoot straps	6
8 Test report	7
9 Marking	7
10 Information supplied by the manufacturer	8
11 Pictogram	8

iTeh STANDARD PREVIEW
(standards.iteh.ai)

[ISO 11393-5:2001](https://standards.iteh.ai/catalog/standards/sist/0130d69e-872b-49b7-8ea1-ccc668fa0937/iso-11393-5-2001)

<https://standards.iteh.ai/catalog/standards/sist/0130d69e-872b-49b7-8ea1-ccc668fa0937/iso-11393-5-2001>

Foreword

ISO (the International Organization for Standardization) is a worldwide federation of national standards bodies (ISO member bodies). The work of preparing International Standards is normally carried out through ISO technical committees. Each member body interested in a subject for which a technical committee has been established has the right to be represented on that committee. International organizations, governmental and non-governmental, in liaison with ISO, also take part in the work. ISO collaborates closely with the International Electrotechnical Commission (IEC) on all matters of electrotechnical standardization.

International Standards are drafted in accordance with the rules given in the ISO/IEC Directives, Part 3.

Draft International Standards adopted by the technical committees are circulated to the member bodies for voting. Publication as an International Standard requires approval by at least 75 % of the member bodies casting a vote.

Attention is drawn to the possibility that some of the elements of this part of ISO 11393 may be the subject of patent rights. ISO shall not be held responsible for identifying any or all such patent rights.

International Standard ISO 11393-5 was prepared by Technical Committee ISO/TC 94, *Personal safety — Protective clothing and equipment*, Subcommittee SC 13, *Protective clothing*. It is based on EN 381-8:1997 and EN 381-9:1997.

ISO 11393 consists of the following parts, under the general title *Protective clothing for users of hand-held chain-saws*:

- Part 1: Test rig driven by a flywheel for testing resistance to cutting by a chain-saw
- Part 2: Test methods and performance requirements for leg protectors
- Part 3: Test methods for footwear
- Part 4: Test methods and performance requirements for protective gloves
- Part 5: Test methods and performance requirements for protective gaiters

Test methods and performance requirements for jackets with protection against cuts by hand-held chain saws will be the subject of a future part 6 to ISO 11393.

Introduction

This part of ISO 11393 forms part of a series concerned with personal protective equipment designed to protect against the risks arising from the use of hand-held chain-saws.

No personal protective equipment can ensure a 100 % protection against cutting from a hand-held chain-saw. Nevertheless, experience has shown that it is possible to design personal protective equipment which offers a certain degree of protection.

Different functional principles may be applied in order to give protection.

These include:

- a) chain slipping: on contact the chain does not cut the material;
- b) clogging: fibres are drawn by the chain into the drive sprocket and block chain movement;
- c) chain braking: fibres have a high resistance to cutting and absorb rotational energy, thereby reducing the chain speed.

Often more than one principle is applied.

iTeh STANDARD PREVIEW (standards.iteh.ai)

[ISO 11393-5:2001](https://standards.iteh.ai/catalog/standards/sist/0130d69e-872b-49b7-8ea1-ccc668fa0937/iso-11393-5-2001)

<https://standards.iteh.ai/catalog/standards/sist/0130d69e-872b-49b7-8ea1-ccc668fa0937/iso-11393-5-2001>

iTeh STANDARD PREVIEW
(standards.iteh.ai)

ISO 11393-5:2001

<https://standards.iteh.ai/catalog/standards/sist/0130d69e-872b-49b7-8ea1-ccc668fa0937/iso-11393-5-2001>

Protective clothing for users of hand-held chain-saws —

Part 5:

Test methods and performance requirements for protective gaiters

1 Scope

This part of ISO 11393 specifies requirements and the test methods to be used to assess the resistance of gaiters to cutting by hand-held chain-saws and other properties. A requirement and a test method for assessing the strength of underfoot straps of gaiters is also included.

This part of ISO 11393 is applicable to gaiters which are to be used in conjunction with safety footwear with a metallic toecap complying with ISO 8782-2, because gaiters alone offer only partial protection against chain-saw cutting.

This part of ISO 11393 is not applicable to gaiters intended for use in situations where there is a significant risk of tripping such as tree climbing or in forests.

2 Normative references

The following normative documents contain provisions which, through reference in this text, constitute provisions of this part of ISO 11393. For dated references, subsequent amendments to, or revisions of, any of these publications do not apply. However, parties to agreements based on this part of ISO 11393 are encouraged to investigate the possibility of applying the most recent editions of the normative documents indicated below. For undated references, the latest edition of the normative document referred to applies. Members of ISO and IEC maintain registers of currently valid International Standards.

ISO 868, *Plastics and ebonite — Determination of indentation hardness by means of a durometer (Shore hardness)*

ISO 3175-2:1998, *Textiles — Dry cleaning and finishing — Part 2: Procedures for tetrachloroethene*

ISO 6330:2000, *Textiles — Domestic washing and drying procedures for textile testing*

ISO 8782-2, *Safety, protective and occupational footwear for professional use — Part 2: Specification for safety footwear*

ISO 11393-1:1998, *Protective clothing for users of hand-held chain-saws — Part 1: Test rig driven by a flywheel for testing resistance to cutting by a chain-saw*

ISO 11393-3:1999, *Protective clothing for users of hand-held chain-saws — Part 3: Test methods for footwear*

3 Terms and definitions

For the purposes of this part of ISO 11393, the following terms and definitions apply.

3.1

foot protector

any product which protects the foot and the lower part of the leg (or any part of this area) against cutting by a hand-held chain-saw

3.2

gaiter

removable covering intended to protect the front part of the foot, ankle and lower leg against cutting by a hand-held chain-saw

3.3

protective material

material which is designed to protect the wearer against the cutting effect of a hand-held chain-saw

4 Requirements

4.1 Fasteners

4.1.1 General

Gaiter fasteners shall not be of touch and close type.

4.1.2 Underfoot straps

When tested in accordance with the procedure described in clause 7, each underfoot strap shall not fail at a force below 250 N.

When tested in accordance with the procedure described in clause 7, the distance moved by the hook between loads of 25 N and 250 N shall be less than 50 mm.

4.2 Specified protective area

<https://standards.iteh.ai/catalog/standards/sist/0130d69e-872b-49b7-8ea1-ccc668fa0937/iso-11393-5-2001>
ISO 11393-5:2001

The protective material of the gaiter shall at least cover the area of the artificial boots (see 6.3.2.1) shown in Figure 1 i.e.:

- a) horizontally: from a line no more than 14 mm behind the end of the artificial boot, to two lines in the same vertical plane sited at least 80 mm either side of the centreline of the front of the boot, measured at a height of (225 ± 2) mm above the lower surface of the artificial boot;
- b) vertically: from the line no more than 25 mm above the lower surface of the artificial boot to at least 200 mm above this line.

4.3 Classification according to chain speed

The classification shall be made with the following four speeds:

- Class of protection 0: 16 m/s \pm 0,2 m/s
- Class of protection 1: 20 m/s \pm 0,2 m/s
- Class of protection 2: 24 m/s \pm 0,2 m/s
- Class of protection 3: 28 m/s \pm 0,2 m/s

4.4 Requirements to cut resistance

When tested according to 6.4, no cut through the leather covering the boot form is allowed for any tested specimen.

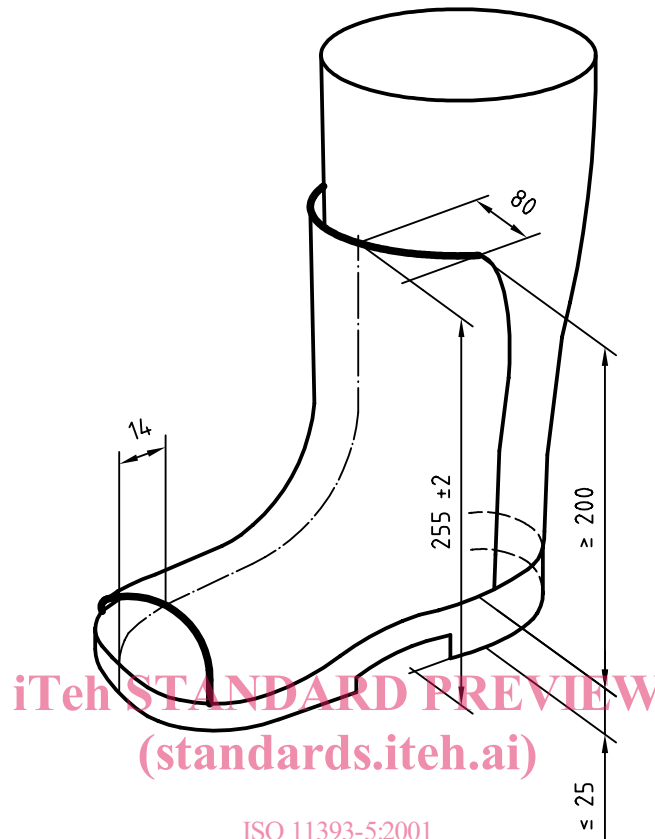

ISO 11393-5:2001
<https://standards.iteh.ai/catalog/standards/sist/0130d69e-872b-49b7-8ea1-3c005075e71b/iso-11393-5:2001>
Figure 1 — Specified protective area (as marked on the artificial boot)

5 Pretreatment

Except in the specific cases detailed below, all the test specimens shall be washed and dried five times before testing.

This washing shall be performed according to procedure 2A of ISO 6330:2000, and the drying by tumble-drying at a temperature not exceeding 70 °C (procedure E).

Exceptions to this treatment are permitted in the following cases.

- a) The gaiters are marked as unsuitable for washing or dry-cleaning.

In such cases, the gaiters shall be immersed in water (20 °C) for 10 min and then allowed to line-dry until more than 95 % of the water has evaporated, measured by mass.

- b) The gaiters are marked as unsuitable for washing, but suitable for dry-cleaning.

In such cases, the test specimens shall be dry-cleaned three times before testing. The dry-cleaning shall be performed principally in accordance with the conditions described in 8.1 of ISO 3175-2:1998, i.e. using conditioned specimens, tetrachloroethene with surfactant, addition of emulsified water, cleaning for 15 min at (30 ± 3) °C, draining and extracting, rinsing for 5 min with pure solvent, and draining and final extraction. Tumble dry with an outlet temperature not exceeding 60 °C. Do not perform a restorative finishing procedure.

- c) The gaiters are marked as suitable for both washing and dry-cleaning.

In such cases, the test shall be carried out on both washed specimens and dry-cleaned specimens, (2 sets of specimens) or, at the request of the manufacturer, on one set of specimens first dry-cleaned and then washed.

d) The gaiters are marked as unsuitable for tumble-drying.

In such cases, the specimens shall be washed by the method described above, then line-dried until more than 95 % of the water has evaporated, as measured by mass.

6 Testing of the resistance to the chain-saw

6.1 Principle

Each gaiter is mounted on an artificial boot and its resistance to a chain-saw is then assessed by applying a moving chain of known speed and inertia characteristics to the boot and gaiter and determining whether or not the chain cuts through the gaiter.

For the purpose of testing gaiters, it is recommended that the test rig be fitted with some means of limiting the depth of cut into the artificial boot in cases where the gaiter fails to resist the chain.

6.2 Test specimens

Three pairs of gaiters are required for each pretreatment method applied. All the specimens shall be of a size suitable for wear over a Paris-point (stitch) size 42 boot (UK size 8).

6.3 Apparatus

6.3.1 Test rig, as described in ISO 11393-1.

6.3.2 Mounting device for gaiters.

6.3.2.1 Left and right artificial boots, moulded from a rigid polyurethane¹⁾, having a density of $1,1 \times 10^3 \text{ kg/m}^3$ and a hardness 95 Shore A determined according to ISO 868.

Their shape and dimensions are shown in Figures 2, 3 and 4. Figures 2, 3 and 4 show a left boot. Right boots have the same dimensions, but their cross-sectional shapes are mirror images of those shown. Furthermore, the boots shall be covered with a layer of $(1,6 \pm 0,1)$ mm full-chrome side upper leather. The area covered by the leather shall correspond at least to the specified protective area described in 4.2.

6.3.2.2 Base for mounting artificial boots, which is the same base as used for mounting normal boots described in ISO 11393-3.

6.4 Procedure

6.4.1 General

Use the calibration procedures given in ISO 11393-1. After calibration, make the following changes.

- Arrange the chain-saw unit in accordance with ISO 11393-1, but use a load of $(30 \pm 0,5)$ N instead of 15 N (see 5.3.5 in ISO 11393-1:1998).
- Place the centre of the sprocket at a horizontal distance of (300 ± 2) mm from the point of contact (see Figure 3 in ISO 11393-1:1998).

1) Suitable artificial boots are obtainable from SATRA Footwear Technology Centre, Kettering, Northants, United Kingdom. This information is given for the convenience of user of this part of ISO 11393 and does not constitute an endorsement by ISO of this product. Equivalent products may be used if they can be shown to lead to the same results.

6.4.2 Mounting of gaiter on artificial boot

Attach the gaiter securely to the appropriate artificial boot (i.e. either left or right) in the same manner as it would be in wear, i.e. by means of its own fastening devices (e.g. straps, buckles).

6.4.3 Cutting

6.4.3.1 General

Test cuts are performed on both right and left gaiters at the positions shown in Figure 5, i.e.

- on the vamp (Position 1),
- at the throat (Position 2),
- at the leg front (Position 3).

Where possible, avoid cutting into any fastenings which may be fitted to the gaiters as this can lead to anomalous results. However, should this not be possible, then record this fact in the test report.

Carry out each test at one speed on three pretreated pairs of gaiters. Each complete test shall consist of a total of six cuts, i.e. 2 cuts on the vamp, 2 cuts on the throat and 2 cuts on the leg front, with no more than one cut being made on any one gaiter.

Carry out the test cuts at the following chain speed(s) as required by the client. If no information is available, perform the test at a chain speed of 20 m/s:

- Class of protection 0: 16 m/s \pm 0,2 m/s
- Class of protection 1: 20 m/s \pm 0,2 m/s
- Class of protection 2: 24 m/s \pm 0,2 m/s
- Class of protection 3: 28 m/s \pm 0,2 m/s

After each test, check the specimen and determine whether it has been cut through. Report the result.

6.4.3.2 Cuts on the vamp area

Attach the gaiter first to the boot as specified in 6.4.2. Then ensure that the combined assembly is then securely fixed to the base in such a way that:

- a) the sole of the artificial boot is in contact with the base in both the heel and forepart positions;
- b) the central plane of the artificial boot coincides with that of the base.

Take care to ensure that no part of the gaiter or its fastenings are trapped between the artificial boot and the base.

Orientate the base at 0° to the horizontal and the central plane of the artificial boot at an angle of 90° to the guide bar, the right side of the boot facing (or nearest to) the pivot of the chain-saw test rig.

This arrangement is shown in Figure 6.

Make test cuts in Position 1 as indicated in Figure 5 [i.e. on the left side of the gaiter, (90 \pm 10) mm to the rear of the extreme toe position of the artificial boot, as measured along its centreline].

6.4.3.3 Cuts on the throat area

Securely fix the combined assembly of the gaiter and the artificial boot to the base as specified in 6.4.3.2.