**Protective clothing for users of hand-held
chain-saws —**

Part 3:
Test methods for footwear

*Vêtements de protection pour utilisateurs de scies à chaîne tenues à la
main —*

Partie 3: Méthodes d'essai pour chaussures

ISO 11393-3:1999

<https://standards.iteh.ai/catalog/standards/sist/b247668c-77f1-4608-84ce-14ecee19b491/iso-11393-3-1999>



Foreword

ISO (the International Organization for Standardization) is a worldwide federation of national standards bodies (ISO member bodies). The work of preparing International Standards is normally carried out through ISO technical committees. Each member body interested in a subject for which a technical committee has been established has the right to be represented on that committee. International organizations, governmental and non-governmental, in liaison with ISO, also take part in the work. ISO collaborates closely with the International Electrotechnical Commission (IEC) on all matters of electrotechnical standardization.

International Standards are drafted in accordance with the rules given in the ISO/IEC Directives, Part 3.

Draft International Standards adopted by the technical committees are circulated to the member bodies for voting. Publication as an International Standard requires approval by at least 75 % of the member bodies casting a vote.

International Standard ISO 11393 was prepared by Technical Committee ISO/TC 94, *Personal safety — Protective clothing and equipment*, Subcommittee SC 13, *Protective clothing*.

ISO 11393 consists of the following parts, under the general title *Protective clothing for users of hand-held chain-saws*:

- Part 1: Test rig driven by a flywheel for testing resistance to cutting by a chain-saw
- Part 2: Test methods and performance requirements for leg protectors
- Part 3: Test methods for footwear
- Part 4: Test methods and performance requirements for protective gloves
- Part 5: Test methods and performance requirements for protective gaiters
- Part 6: Test methods and performance requirements for jackets with protection against cuts by hand-held chain-saws

© ISO 1999

All rights reserved. Unless otherwise specified, no part of this publication may be reproduced or utilized in any form or by any means, electronic or mechanical, including photocopying and microfilm, without permission in writing from the publisher.

International Organization for Standardization
Case postale 56 • CH-1211 Genève 20 • Switzerland
Internet iso@iso.ch

Printed in Switzerland

Introduction

This part of ISO 11393 forms part of a series concerned with personal protective equipment designed to protect against the risks arising from the use of hand-held chain-saws.

No personal protective equipment can ensure a 100 % protection against cutting from a hand-held chain-saw. Nevertheless, experience has shown that it is possible to design personal protective equipment which offers a certain degree of protection.

Different functional principles may be applied in order to give protection.

These include:

- a) chain slipping: on contact the chain does not cut the material;
- b) clogging: fibres are drawn by the chain into the drive sprocket and block chain movement;
- c) chain braking: fibres have a high resistance to cutting and absorb rotational energy, thereby reducing the chain speed.

Often more than one principle is applied.

iTeh STANDARD PREVIEW
(standards.iteh.ai)

[ISO 11393-3:1999](https://standards.iteh.ai/catalog/standards/sist/b247668c-77f1-4608-84ce-14ecee19b491/iso-11393-3-1999)

<https://standards.iteh.ai/catalog/standards/sist/b247668c-77f1-4608-84ce-14ecee19b491/iso-11393-3-1999>

iTeh STANDARD PREVIEW
(standards.iteh.ai)

ISO 11393-3:1999

<https://standards.iteh.ai/catalog/standards/sist/b247668c-77f1-4608-84ce-14ecee19b491/iso-11393-3-1999>

Protective clothing for users of hand-held chain-saws —

Part 3: Test methods for footwear

1 Scope

This part of ISO 11393 specifies test methods to be used to assess the resistance of footwear to cutting by hand-held chain-saws.

This part of ISO 11393 is applicable only to footwear with integral protection.

NOTE Methods for testing other forms of foot and leg protection (e.g. gaiters) against hand-held chain-saws will be covered in other parts of ISO 11393.

2 Normative references

The following normative documents contain provisions which, through reference in this text, constitute provisions of this part of ISO 11393. For dated references, subsequent amendments to, or revisions of, any of these publications do not apply. However, parties to agreements based on this part of ISO 11393 are encouraged to investigate the possibility of applying the most recent editions of the normative documents indicated below. For undated references, the latest edition of the normative document referred to applies. Members of ISO and IEC maintain registers of currently valid International Standards.

ISO 3386-1, *Polymeric materials, cellular flexible — Determination of stress-strain characteristics in compression — Part 1: Low-density materials.*

ISO 8782-1:1998, *Safety, protective and occupational footwear for professional use — Part 1: Requirements and test methods.*

ISO 8782-5, *Safety, protective and occupational footwear for professional use — Part 5: Additional requirements and test methods.*

ISO 8782-6, *Safety, protective and occupational footwear for professional use — Part 6: Additional specifications for safety footwear.*

ISO 11393-1:1998, *Protective clothing for users of hand-held chain-saws — Part 1: Test rig driven by a flywheel for testing resistance to cutting by a chain-saw.*

3 Term and definition

For the purposes of this part of ISO 11393, the following term and definition apply.

3.1

footwear with integral protection

footwear in which the chain-saw protective material either comprises the material of the footwear or is permanently attached to the footwear

4 Test specimens

For footwear with metallic toecaps, three pairs, size 42 (Paris points), size 8 (UK) shall be tested.

For footwear with non-metallic toecaps, four pairs, size 42 (Paris points), size 8 (UK) shall be tested.

5 Checking of protective coverage

5.1 Apparatus

5.1.1 Sizing body for laced footwear, of total height 500 mm min., comprising:

- ankle cylinder: height (76 ± 1) mm; diameter (84 ± 1) mm;
- conical section: height (274 ± 1) mm;
- upper cylinder: height 150 mm min.; diameter (110 ± 1) mm.

See Figure 1.

5.2 Procedure

Insert the sizing body for laced footwear into the leg of the footwear and tighten any fastenings (e.g. laces or straps) about it. Check that the coverage requirements given in ISO 8782-5 and ISO 8782-6 are fulfilled.

6 Testing of resistance to cutting

6.1 Apparatus

6.1.1 Test rig

ISO 11393-3:1999
<https://standards.iteh.ai/catalog/standards/sist/b247668c-77f1-4608-84ce-14ecee19b491/iso-11393-3-1999>

The test rig is as described in ISO 11393-1 with additional elements to fulfil the requirements of 6.2.

6.1.2 Footwear mounting devices

6.1.2.1 Base, for mounting the footwear, capable of holding the footwear in the required positions.

The base may have holes (for bolts) or devices for fixing the footwear. Such devices shall not interfere with the chain-saw protective material of the footwear.

6.1.2.2 Artificial shinbone, made of hardwood or similar material, covered with a (14 ± 2) mm thick layer of flexible cellular material of copolymer foam of ethylene vinyl acetate with specific density (50 ± 2) kg/m³ and a compression stress value at 40 % compression (CV 40) of (75 ± 10) kPa, as tested in accordance with ISO 3386-1.

Its length shall be at least 700 mm, with circular cross-section diameter (50 ± 1) mm plus the thickness of the cellular material.

See Figure 2.

6.1.3 Material for filling footwear, comprising:

- dried peas of diameter approximately 7 mm, and
- bag containing (2 ± 0,1) kg of lead shot or similar.

6.2 Test procedure

6.2.1 General

Calibration procedures shall be as in ISO 11393-1.

After calibration the following changes in procedure are introduced:

- a) the chain-saw unit is arranged as in ISO 11393-1, but the load shall be $(30 \pm 0,5)$ N instead of 15 N (see 5.3.4 in ISO 11393-1:1998);
- b) the horizontal distance from the point of contact to the centre of the sprocket shall be (300 ± 2) mm (see Figure 3 in ISO 11393-1:1998).

Test cuts are performed on both right and left footwear at the positions shown in Figure 3, i.e.

- on the left side of the vamp (position 1);
- at the throat (position 2);
- at the leg front (position 3);
- on the toecap (position 4) (footwear with non-metallic toecaps).

Where possible, avoid cutting into any fastenings which may be fitted to the footwear as this could lead to anomalous results. Should this not be possible, such cutting should be recorded in the test report.

A total of six cuts, or eight cuts for footwear with non-metallic toecaps, should be made for each complete test, with no more than one cut being made on any one sample.

Test cuts according to this part of ISO 11393 may be carried out with the following chain speeds:

- Class 0: 16 m/s;
- Class 1: 20 m/s;
- Class 2: 24 m/s;
- Class 3: 28 m/s.

<https://standards.iteh.ai/catalog/standards/sist/b247668c-77f1-4608-84ce-14ecee19b491/iso-11393-3-1999>

NOTE Class 0 is valid until 1999-12-31.

After each test check the specimen for cut through and report the result.

6.2.2 Cuts on vamp area

First securely fix the footwear to the base in such a way that:

- a) the sole of the footwear is in contact with the base in both the heel and forepart without changing the natural shape of the footwear;
- b) the test axis as defined in ISO 8782-1:1998, subclause 5.3.2.1, coincides with that of the base.

The base is then tilted at $(30 \pm 2)^\circ$ to the horizontal in such a manner that the right side of the footwear is lowermost and nearest the pivot of the test rig, and the test axis of the footwear is at an angle of $(90 \pm 3)^\circ$ to the guide bar (see Figure 4).

Sufficient dried peas (6.1.3) are poured into the footwear to completely fill the foot section and at least half of the leg. The peas are kept in place with the bag of lead shot (6.1.3).

Perform test cuts at the positions indicated in Figure 3 as position 1 (i.e. on the left side of the footwear, (15 ± 5) mm to the rear of the toecaps).

6.2.3 Cuts on throat area

Securely fix the footwear to the base as in 6.2.2.

The base is then tilted (45 ± 2)° to the horizontal in such a manner that the heel of the footwear is lowermost, and the test axis of the footwear is vertical and at an angle of (90 ± 3)° to the guide bar of the test rig. The right side of the footwear shall be nearest to the pivot (see Figure 5).

Perform test cuts at the positions indicated in Figure 3 as position 2.

6.2.4 Cuts on leg region

If the leg of the footwear is fitted with any fastening devices (e.g. laces or straps), fasten these around the sizing body for laced footwear (5.1.1). Remove the sizing body from the footwear.

If necessary, cut away the heel and as little as possible of the quarter region of the footwear, taking care not to damage nor interfere with any of the chain-saw protective material. If the protective material is damaged or interfered with, report this.

Mount the leg of the footwear over the artificial shinbone (6.1.2.2), taking care that any damage caused to the footwear does not interfere with the chain-saw protective material. If such damage does occur, report this in the test report.

Securely fasten the footwear to the artificial shinbone. The fastening should be on the left side of the footwear. An example of a suitable fastening system is shown in Figure 6, but alternative systems are also allowed.

Apply a line loading of (50 ± 1) N/m.

Then position the artificial shinbone so that the front of the leg of the footwear is uppermost, and the central plane of the footwear is vertical and at an angle of (90 ± 2)° to the guide bar of the test rig.

The left side of the footwear shall be opposite the pivot (see Figure 6).

Carry out the test cut at a distance of (150 ± 30) mm from the upper surface of the insock of the middle of the heel and at an angle of (90 ± 3)° to the line of the leg (see Figure 3, position 3) without deforming its shape and taking care to avoid any fastenings (e.g. hooks or eyelets).

6.2.5 Additional cuts for footwear with non-metallic toecaps

If the footwear is supplied with non-metallic toecaps, perform extra cuts to check that the toecaps can withstand chain-saw cutting. Mount one left and one right footwear as described in 6.2.2 and carry out the tests at the positions indicated in Figure 3 as position 4.

7 Test report

The report shall include at least the following:

- identification and description of the test specimen (e.g. manufacturer, style, design, size, components);
- type of toecap with reference to ISO 8782-1:1998, subclause 4.3.2;
- test result for each test area cut;
- chain speed and class;
- evaluation of damages and chain-stopping mechanism;
- result of inspections and checkings having no specific test methods.

Dimensions in millimetres

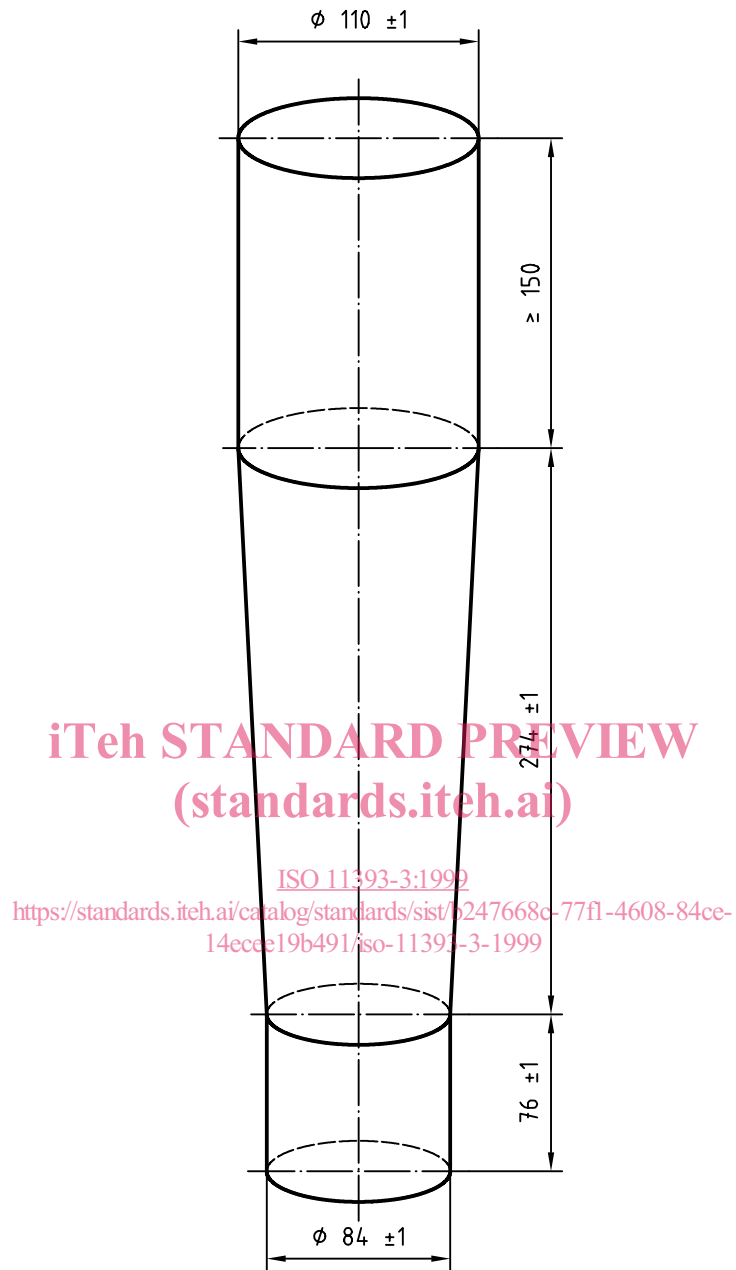

Figure 1 — Sizing body for laced footwear