

**Telecommunications and Internet converged Services and
Protocols for Advanced Networking (TISPAN);
Resource and Admission Control;
Protocol for QoS reservation information exchange between
the Service Policy Decision Function (SPDF) and the
Access-Resource and Admission Control Function (A-RACF)
in the Resource and Protocol specification**

ETSI STANDARD PREVIEW
(standards.iteh.ai)
Full standard:
<https://standards.iteh.ai/catalog/standards/sist/f3ab0ac9-8e90-40d6-8d75-e4e60e26ad3/etsi-es-283-026-v1.6.0-2008-04>



Reference

RES/TISPAN-03141-NGN-R1

Keywords

interface, stage 3

ETSI

650 Route des Lucioles
F-06921 Sophia Antipolis Cedex - FRANCE

Tel.: +33 4 92 94 42 00 Fax: +33 4 93 65 47 16

Siret N° 348 623 562 00017 - NAF 742 C
Association à but non lucratif enregistrée à la
Sous-Préfecture de Grasse (06) N° 7803/88

Important notice

Individual copies of the present document can be downloaded from:

<http://www.etsi.org>

The present document may be made available in more than one electronic version or in print. In any case of existing or perceived difference in contents between such versions, the reference version is the Portable Document Format (PDF). In case of dispute, the reference shall be the printing on ETSI printers of the PDF version kept on a specific network drive within ETSI Secretariat.

Users of the present document should be aware that the document may be subject to revision or change of status. Information on the current status of this and other ETSI documents is available at

<http://portal.etsi.org/tb/status/status.asp>

If you find errors in the present document, please send your comment to one of the following services:

http://portal.etsi.org/chaicor/ETSI_support.asp

Copyright Notification

No part may be reproduced except as authorized by written permission.
The copyright and the foregoing restriction extend to reproduction in all media.

© European Telecommunications Standards Institute 2008.
All rights reserved.

DECT™, PLUGTESTS™, UMTS™, TIPHON™, the TIPHON logo and the ETSI logo are Trade Marks of ETSI registered for the benefit of its Members.

3GPP™ is a Trade Mark of ETSI registered for the benefit of its Members and of the 3GPP Organizational Partners.

Contents

Intellectual Property Rights	5
Foreword.....	5
1 Scope	6
2 References	6
2.1 Normative references	6
3 Definitions and abbreviations.....	7
3.1 Definitions.....	7
3.2 Abbreviations	7
4 Rq interface	8
4.1 Overview	8
4.2 Rq reference model	8
4.3 Functional elements and capabilities	9
4.3.1 Service-based Policy Decision Function (SPDF)	9
4.3.2 Access-Resource and Admission Control Function (A-RACF)	9
5 Resource control procedures	9
5.1 Procedures at the SPDF	10
5.1.1 Initial Reservation for a Session	10
5.1.2 Session Modification	12
5.1.3 Session Termination	13
5.1.4 Event notification.....	13
5.2 Procedures at the A-RACF	14
5.2.1 Initial Reservation for a Session	14
5.2.2 Session Modification	16
5.2.3 Session Termination	16
5.2.4 Event Notification.....	17
6 Rq protocol.....	17
6.1 Protocol support	17
6.1.1 Advertising Application Support	17
6.1.2 Transport protocol	17
6.1.3 Securing Rq messages	17
6.2 Rq messages	18
6.2.1 AA-Request (AAR) Command.....	18
6.2.2 AA-Answer (AAA) Command.....	18
6.2.3 Re-Auth-Request (RAR) Command	18
6.2.4 Re-Auth-Answer (RAA) Command	19
6.2.5 Session-Termination-Request (STR) Command.....	19
6.2.6 Session-Termination-Answer (STA) Command.....	20
6.2.7 Abort-Session-Request (ASR) Command	20
6.2.8 Abort-Session-Answer (ASA) Command.....	20
6.3 Experimental-Result-Code AVP values	21
6.3.1 Experimental-Result-Code AVP values imported from TS 129 209	21
6.3.2 Experimental-Result-Code AVP values defined in the present document.....	21
6.4 AVPs	21
6.4.1 AVPs defined in the present document.....	21
6.4.2 AVPs imported from TS 129 209	22
6.4.3 AVPs imported from TS 183 017	22
6.4.4 AVPs imported from ES 283 034	23
6.4.5 Abort-Cause AVP	23
6.4.6 AF-Application-Identifier AVP	23
6.4.7 Flow-Description AVP	24
6.4.8 Flow-Grouping AVP.....	24
6.4.9 Flow-Number AVP.....	24
6.4.10 Flows AVP.....	24

6.4.11	Flow-Status AVP	25
6.4.12	Flow-Usage AVP	25
6.4.13	Specific-Action AVP	25
6.4.14	Max-Requested-Bandwidth-DL AVP	26
6.4.15	Max-Requested-Bandwidth-UL AVP	26
6.4.16	Media-Component-Description AVP	26
6.4.17	Media-Component-Number AVP	27
6.4.18	Media-Sub-Component AVP	27
6.4.19	Media-Type AVP	27
6.4.20	Reservation-Class AVP	27
6.4.21	Globally-Unique-Address AVP	28
6.4.22	Address-Realm AVP	28
6.4.23	Reservation-Priority AVP	28
6.4.24	Session-Bundle-Id AVP	28
6.4.25	AF-Charging-Identifier AVP	28
6.4.26	Service-Class AVP	28
6.4.27	Transport-Class AVP	29
Annex A (informative): Resource reservation flow states maintained by A-RACF		30
History		32

iTeh STANDARD PREVIEW
 (standards.iteh.ai)

Full standard:
<https://standards.iteh.ai/catalog/standards/sist/f3ab0ac9-8e90-40d6-8d75-e4e600e26ad3/etsi-es-283-026-v1.6.0-2008-04>

Intellectual Property Rights

IPRs essential or potentially essential to the present document may have been declared to ETSI. The information pertaining to these essential IPRs, if any, is publicly available for **ETSI members and non-members**, and can be found in ETSI SR 000 314: "*Intellectual Property Rights (IPRs); Essential, or potentially Essential, IPRs notified to ETSI in respect of ETSI standards*", which is available from the ETSI Secretariat. Latest updates are available on the ETSI Web server (<http://webapp.etsi.org/IPR/home.asp>).

Pursuant to the ETSI IPR Policy, no investigation, including IPR searches, has been carried out by ETSI. No guarantee can be given as to the existence of other IPRs not referenced in ETSI SR 000 314 (or the updates on the ETSI Web server) which are, or may be, or may become, essential to the present document.

Foreword

This ETSI Standard (ES) has been produced by ETSI Technical Committee Telecommunications and Internet converged Services and Protocols for Advanced Networking (TISPAN), and is now submitted for the ETSI standards Membership Approval Procedure.

iTeh STANDARD PREVIEW
(standards.iteh.ai)

Full standard:
<https://standards.iteh.ai/catalog/standards/sist/f3ab0ac9-8e90-40d6-8d75-e4e600e26ad3/etsi-es-283-026-v1.6.0-2008-04>

1 Scope

The present document provides the stage 3 specification of the Rq interface. The functional requirements and the stage 2 specifications of the Rq interface are contained in ES 282 001 [1] and ES 282 003 [2]. The Rq interface is the interface between the Service Policy Decision Function (SPDF) and the Access - Resource and Admission Control Function (A-RACF) and is used for QoS resource reservation information exchange between the SPDF and the A-RACF. Via the Rq interface the SPDF issues requests for resources in the access network, indicating IP QoS characteristics. The A-RACF uses the IP QoS information to perform admission control and indicate to the SPDF via the Rq interface its admission control decisions. Due to the possible business roles in an access environment, the SPDF may be either in the same domain or in a different domain as the A-RACF.

The present document defines:

- The information to be exchanged between SPDF and A-RACF over the Rq interface.
- An Rq interface definition based on the Diameter protocol.

In situations where no generic overload control mechanism is used on the Rq interface, the interface shall only be capable of supporting a one-to-one relationship between the A-RACF and SPDF (i.e. one SPDF may only contact one A-RACF, and that A-RACF may only contact that same SPDF). Overload control need not be supported in this situation due to the fact that it should be possible to traffic engineer the capabilities of the two entities, so that the capacity of one entity matches the capacity of the other.

2 References

References are either specific (identified by date of publication and/or edition number or version number) or non-specific.

- For a specific reference, subsequent revisions do not apply.
- Non-specific reference may be made only to a complete document or a part thereof and only in the following cases:
 - if it is accepted that it will be possible to use all future changes of the referenced document for the purposes of the referring document;
 - for informative references.

Referenced documents which are not found to be publicly available in the expected location might be found at <http://docbox.etsi.org/Reference>.

For online referenced documents, information sufficient to identify and locate the source shall be provided. Preferably, the primary source of the referenced document should be cited, in order to ensure traceability. Furthermore, the reference should, as far as possible, remain valid for the expected life of the document. The reference shall include the method of access to the referenced document and the full network address, with the same punctuation and use of upper case and lower case letters.

NOTE: While any hyperlinks included in this clause were valid at the time of publication ETSI cannot guarantee their long term validity.

2.1 Normative references

The following referenced documents are indispensable for the application of the present document. For dated references, only the edition cited applies. For non-specific references, the latest edition of the referenced document (including any amendments) applies.

- [1] ETSI ES 282 001: "Telecommunications and Internet converged Services and Protocols for Advanced Networking (TISPAN); NGN Functional Architecture Release 1".

- [2] ETSI ES 282 003: "Telecommunications and Internet converged Services and Protocols for Advanced Networking (TISPAN); Resource and Admission Control Sub-system (RACS); Functional Architecture".
- [3] ETSI ES 282 004: "Telecommunications and Internet converged Services and Protocols for Advanced Networking (TISPAN); NGN Functional Architecture; Network Attachment Sub-System (NASS)".
- [4] ETSI ES 283 034: "Telecommunications and Internet converged Services and Protocols for Advanced Networking (TISPAN); Network Attachment Sub-System (NASS); e4 interface based on the DIAMETER protocol".
- [5] ETSI TS 183 017: "Telecommunications and Internet converged Services and Protocols for Advanced Networking (TISPAN); Resource and Admission Control: DIAMETER protocol for session based policy set-up information exchange between the Application Function (AF) and the Service Policy Decision Function (SPDF); Protocol specification".
- [6] ETSI TS 129 207: "Digital cellular telecommunications system (Phase 2+); Universal Mobile Telecommunications System (UMTS); Policy control over Go interface (3GPP TS 29.207)".
- [7] ETSI TS 129 209: "Universal Mobile Telecommunications System (UMTS); Policy control over Gq interface (3GPP TS 29.209)".
- [8] ETSI TS 133 210: "Digital cellular telecommunications system (Phase 2+); Universal Mobile Telecommunications System (UMTS); 3G security; Network Domain Security (NDS); IP network layer security (3GPP TS 33.210)".
- [9] IETF RFC 2960: "Stream Control Transmission Protocol".
- [10] IETF RCF 3309: "Stream Control Transmission Protocol (SCTP) Checksum Change".
- [11] IETF RFC 3588: "Diameter Base Protocol".
- [12] IETF RFC 4005: "Diameter Network Access Server Application".

3 Definitions and abbreviations

3.1 Definitions

For the purposes of the present document, the following terms and definitions apply:

Attribute-Value Pair (AVP): See RFC 3588 [11], corresponds to an Information Element in a Diameter message.

hard-state reservation: type of reservation whereby the requested resources are reserved without time limit

NOTE: Hard-state reservations are terminated if the DIAMETER session is terminated.

soft-state reservation: type of reservation whereby the requested resources are reserved for a finite amount of time, soft-state reservations are terminated when the DIAMETER session is terminated

3.2 Abbreviations

For the purposes of the present document, the following abbreviations apply:

AAA	AA-Answer
AAR	AA-Request
AF	Application Function
A-RACF	Access-Resource and Admission Control Function
ASA	Abort-Session-Answer
ASR	Abort-Session-Request
ATM VC	Asynchronous Transfer Mode Virtual Circuit

AVP	Attribute-Value Pair
CEA	Capabilities-Exchange-Answer
CER	Capabilities-Exchange-Request
IANA	Internet Assigned Numbers Authority
IP-CAN	IP-Connectivity Access Network
NASREQ	Network Access Server REquirements
NASS	Network Access Sub-System
QoS	Quality of Service
RAA	Re-Auth-Answer
RACF	Resource and Admission Control Function
RACS	Resource and Admission Control Subsystem
RAR	Re-Auth-Request
RCEF	Residual Code Excited Field
SCTP	Stream Control Transfer Protocol
SPDF	Service-based Policy Decision Function
STA	Session-Termination-Answer
STR	Session-Termination-Request
xDSL	x Digital Subscriber Line

4 Rq interface

4.1 Overview

In the following, the Rq interface is described in detail concerning what type of information that needs to be transported between the SPDF and the A-RACF. The Rq reference point is used for resource reservation as defined in ES 282 003 [2]. Due to the possible business roles in an access environment, an SPDF instance may be either in the same domain or in a different domain as the A-RACF instance with which it interacts. This means that Rq reference point should support both the case when an SPDF instance and the A-RACF instance with which it interacts are located in the same domain, and when they are located in different domains.

The Rq reference point is an open vendor interface and an open operator interface. One A-RACF instance shall be able to serve more than one SPDF instance and one given SPDF instance may interact with a number of A-RACF instances, although on a session basis, it shall interact with only a single A-RACF instance.

4.2 Rq reference model

The Rq interface is defined between the SPDF and the A-RACF.

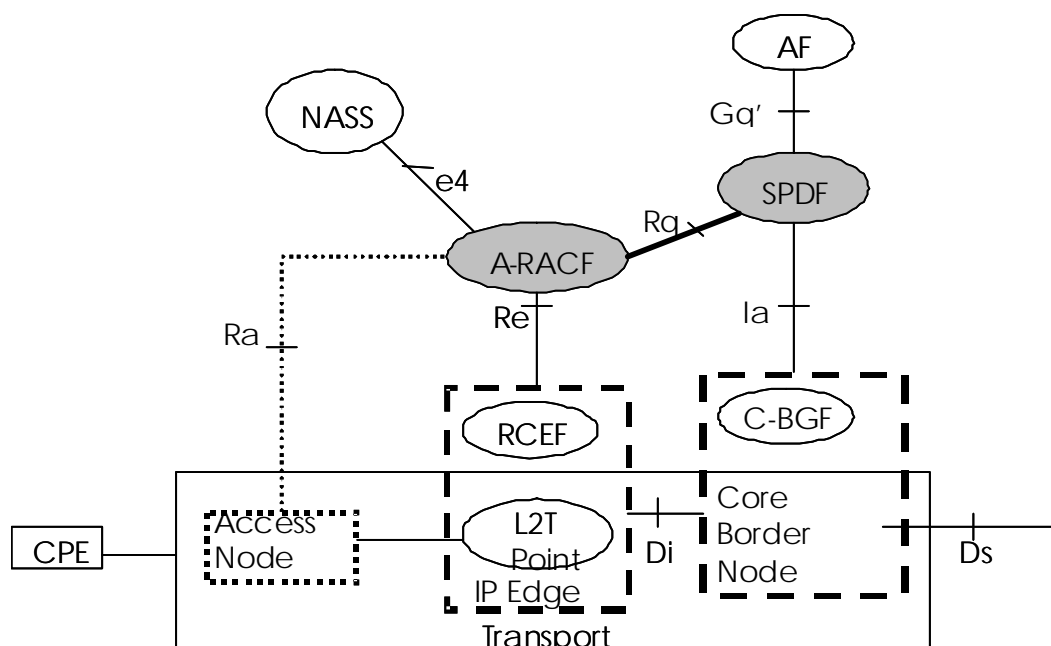

Figure 1: Rq interface architecture model

4.3 Functional elements and capabilities

4.3.1 Service-based Policy Decision Function (SPDF)

The SPDF is a functional element that coordinates the resource reservations requests received from by the AF. The SPDF makes policy decisions using policy rules and forwards the session and media related information obtained from the AF to the A-RACF via the Rq reference point for admission control purposes. The functionality of the SPDF is further detailed in ES 282 003 [2].

4.3.2 Access-Resource and Admission Control Function (A-RACF)

The A-RACF is a functional element performing resource reservation admission control and network policy assembly. The A-RACF receives resource reservation requests from the SPDF via the Rq reference point. The functionality of the SPDF is further detailed in ES 282 003 [2].

5 Resource control procedures

The resource control procedures are defined in seven interaction procedures:

- 1) Reservation.
- 2) Commit.
- 3) Reservation and commit.
- 4) Refresh.
- 5) Modification.
- 6) Release.
- 7) Event notification.

These interactions are described in the following clauses. During the interactions Diameter AVPs are passed between the SPDF and the A-RACF.

Figure 2 describes the flow states as maintained by the A-RACF according to the procedures. Annex A provides a table further clarifying how states change at different events and actions taken by the A-RACF.

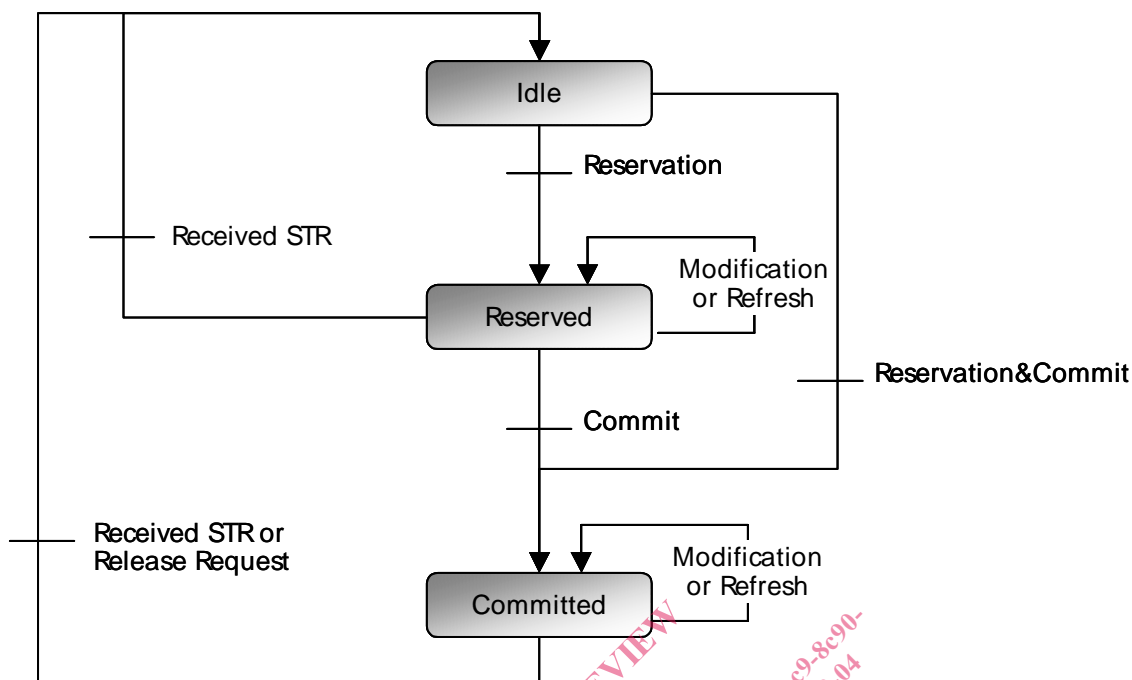

Figure 2: Flow state

The Flow-Status AVP (clause 6.4.11 Flow-Status AVP "Flow-Status AVP") is used to define the action to be taken for each AA-Request made by the SPDF to the A-RACF. The rules for interpreting the Flow-Status AVP are the following:

- Reservation: New Media-Description-Component AVP(s) and Media-Sub-Component AVP(s). Optional Flow-Status AVP(s) set to DISABLED (3).
- Modification: Updated Media-Description-Component AVP(s) and/or Media-Sub-Component AVP(s). Flow-Status AVP not modified, unless the state needs to be modified (e.g. for committing a resource reservation, or for releasing a resource reservation).
- Commit: Media-Description-Component AVP(s) and optionally Media-Sub-Component AVP(s) of existing reservations with Flow-Status AVP(s) set to ENABLED-UPLINK (0), ENABLED-DOWNLINK (1) or ENABLED (2).
- ReservationAndCommit: New Media-Component-Description AVP(s) and Media-Sub-Component AVP(s). Flow-Status AVP(s) set to ENABLED-UPLINK (0), ENABLED-DOWNLINK (1) or ENABLED (2).
- Release: Media-Description-Component AVP(s) and optionally Media-Sub-Component AVP(s) of existing reservations with Flow-Status AVP(s) set to REMOVED (4).
- Refresh: Existing reservation unchanged (Media-Component-Description AVP(s) not specified or unchanged), Flow-Status AVP unchanged.

5.1 Procedures at the SPDF

5.1.1 Initial Reservation for a Session

The SPDF may request the A-RACF to allocate resources for a new session (i.e. make an initial reservation request). The SPDF issues such request by sending an AA-Request message to the A-RACF. This message contains one or more Media-Component-Description Attribute-Value-Pair(s) (AVP(s)). Each Media-Component-Description AVP describes the set of flows of a particular media type (i.e. it contains one or more Media-Sub-Component AVP(s) and requirements for the flows (clause 6.4.16 Media-Component-Description AVP "Media-Component-Description AVP").

The SPDF may in the AA-Request include the Flow-Grouping AVP(s) to request a particular way for how the IP Flows are to be distributed to IP-CAN bearers. The SPDF may also forward an AF-Charging-Identifier AVP from the AF in the message for charging correlation purposes between AF and RACS.

An AA-Request issued to request an initial reservation contains a new Session-Id obtained by the SPDF. As specified in RFC 3588 [11], the Session-Id is globally unique and is meant to uniquely identify a user session without reference to any other information. The Session-Id begins with the sender's identity encoded in the DiameterIdentity type.

The specific action that shall be performed by the A-RACF for each individual media and flow (i.e. the Reserve or the ReserveAndCommit operation) is defined by the Flow-Status AVP:

- Reservation; the value of the Flow-Status AVP shall be set to DISABLED (3).
- ReservationAndCommit; the value of the Flow-Status AVP shall be set to ENABLED-UPLINK (0), ENABLED-DOWNLINK (1) or ENABLED (2).
- The Flow-Status AVP shall be specified in the Media-Component-Description AVP and in the Media-Sub-Component AVP(s). The Flow-Status AVP shall be set to the same value in both these AVPs.

Table 1: Initial Reservation operations

Message Type	Flow-Status AVP at the level of:		Meaning
	Media	Sub-Media	
AAR	New Media, DISABLED	New flow, DISABLED	Reserve Resources for all the flows in the request. The media(s) and flow(s) descriptions MUST be new ones.
AAR	[New Media, ENABLE*]	New flow, ENABLE*	Reserve Resources. In addition, commit resources for some of the flows. The media(s) and flow(s) descriptions MUST be new ones.

As specified in clause 8.9 of RFC 3588 [11], the SPDF may specify the Authorization-Lifetime AVP in the AA-Request to request a maximum lifetime for a session. To request a hard-state session the SPDF shall omit the Authorization-Lifetime AVP in the AA-Request. To request a soft-state session the SPDF shall specify this AVP in the AA-Request.

The AA-Answer may contain the Authorization-Lifetime AVP. The AA-Answer may contain the Auth-Grace-Period AVP in addition to the Authorization-Lifetime AVP. The Authorization-Lifetime AVP specifies the maximum number of seconds before the Session must be refreshed by the SPDF. The Auth-Grace-Period AVP contains the number of seconds the A-RACF will wait for a Refresh following the expiration of the Authorization-Lifetime AVP.

Whether the Authorization-Lifetime AVP and Auth-Grace-Period need to be included in the AA-Answer is a local decision of the A-RACF. This means that the SPDF may be offered a soft-state reservation although it asked for hard-state or a hard-state reservation although it asked for soft-state. Should the SPDF not accept what is offered by the A-RACF it must explicitly terminate the session.

The SPDF may specify the Reservation-Priority AVP (clause 6.4.23) as a main AVP of the AA-Request in order to assign a priority to the request. The SPDF may further specify the Reservation-Priority AVP in Media-Component-Description AVP(s) in order to assign priority to individual media. If the Reservation-Priority AVP is not specified the requested priority is DEFAULT.

The SPDF may specify, in the Specific-Action AVP of the AA-Request through which the initial reservation request is made, the events of which it wants to be informed. The supported events are listed in clause 6.4.13.

Should the AA-Answer contain one or more Session-Bundle-Id AVPs the SPDF shall store the association between the Session-Bundle-Id AVP(s) and the Session-ID AVP of the session in question.

The behaviour when the SPDF does not receive an AA-Answer, or when it arrives after the internal timer waiting for it has expired, or when it arrives with an indication different than DIAMETER_SUCCESS, is outside the scope of the present document.