Fittings made from unplasticized poly(vinyl chloride) (PVC-U), chlorinated poly(vinyl chloride) (PVC-C) or acrylonitrile/butadiene/styrene (ABS) with plain sockets for pipes under pressure —

**Part 2:
Inch-based series**
(standards.iteh.ai)

Raccords en poly(chlorure de vinyle) non plastifié (PVC-U), en poly(chlorure de vinyle) chloré (PVC-C) ou en acrylonitrile/butadiène/styrène (ABS), à emboîtements lisses pour tubes sous pression —

Partie 2: Série basée sur les inches



PDF disclaimer

This PDF file may contain embedded typefaces. In accordance with Adobe's licensing policy, this file may be printed or viewed but shall not be edited unless the typefaces which are embedded are licensed to and installed on the computer performing the editing. In downloading this file, parties accept therein the responsibility of not infringing Adobe's licensing policy. The ISO Central Secretariat accepts no liability in this area.

Adobe is a trademark of Adobe Systems Incorporated.

Details of the software products used to create this PDF file can be found in the General Info relative to the file; the PDF-creation parameters were optimized for printing. Every care has been taken to ensure that the file is suitable for use by ISO member bodies. In the unlikely event that a problem relating to it is found, please inform the Central Secretariat at the address given below.

iTeh STANDARD PREVIEW
(standards.iteh.ai)

[ISO 727-2:2002](https://standards.iteh.ai/catalog/standards/sist/c911a72b-ec85-4e0e-9d59-b8b67d578c4/iso-727-2-2002)

<https://standards.iteh.ai/catalog/standards/sist/c911a72b-ec85-4e0e-9d59-b8b67d578c4/iso-727-2-2002>

© ISO 2002

All rights reserved. Unless otherwise specified, no part of this publication may be reproduced or utilized in any form or by any means, electronic or mechanical, including photocopying and microfilm, without permission in writing from either ISO at the address below or ISO's member body in the country of the requester.

ISO copyright office
Case postale 56 • CH-1211 Geneva 20
Tel. + 41 22 749 01 11
Fax + 41 22 749 09 47
E-mail copyright@iso.ch
Web www.iso.ch

Printed in Switzerland

Foreword

ISO (the International Organization for Standardization) is a worldwide federation of national standards bodies (ISO member bodies). The work of preparing International Standards is normally carried out through ISO technical committees. Each member body interested in a subject for which a technical committee has been established has the right to be represented on that committee. International organizations, governmental and non-governmental, in liaison with ISO, also take part in the work. ISO collaborates closely with the International Electrotechnical Commission (IEC) on all matters of electrotechnical standardization.

International Standards are drafted in accordance with the rules given in the ISO/IEC Directives, Part 3.

Draft International Standards adopted by the technical committees are circulated to the member bodies for voting. Publication as an International Standard requires approval by at least 75 % of the member bodies casting a vote.

Attention is drawn to the possibility that some of the elements of this part of ISO 727 may be the subject of patent rights. ISO shall not be held responsible for identifying any or all such patent rights.

International Standard ISO 727-2 was prepared by Technical Committee ISO/TC 138, *Plastics pipes, fittings and valves for the transport of fluids*, Subcommittee SC 2, *Plastics pipes and fittings for water supplies*.

Together with ISO 727-1, this first edition of ISO 727-2 cancels and replaces ISO 727:1985, which has been technically revised.

ISO 727 consists of the following parts, under the general title *Fittings made from unplasticized poly(vinyl chloride) (PVC-U), chlorinated poly(vinyl chloride) (PVC-C) or acrylonitrile/butadiene/styrene (ABS) with plain sockets for pipes under pressure*:

— Part 1: Metric series

— Part 2: Inch-based series

<https://standards.iteh.ai/catalog/standards/sist/c911a72b-ec85-4e0e-9d59-b8b67d578c4/iso-727-2-2002>

iTeh STANDARD PREVIEW
(standards.iteh.ai)

ISO 727-2:2002

<https://standards.iteh.ai/catalog/standards/sist/c911a72b-ec85-4e0e-9d59-b8bf67d578c4/iso-727-2-2002>

Fittings made from unplasticized poly(vinyl chloride) (PVC-U), chlorinated poly(vinyl chloride) (PVC-C) or acrylonitrile/butadiene/styrene (ABS) with plain sockets for pipes under pressure —

Part 2: Inch-based series

1 Scope

This part of ISO 727 specifies the dimensions, in millimetres, of plain sockets (cylindrical and conical), for the inch-based pipe series, in fittings made from unplasticized poly(vinyl chloride) (PVC-U), chlorinated poly(vinyl chloride) (PVC-C) or acrylonitrile/butadiene/styrene (ABS), intended for connecting by solvent cementing to pipes of the corresponding material for use under pressure. The resulting joint does not require mechanical anchorage.

NOTE It is strongly recommended that the advice of the fittings manufacturer be sought in the selection of an appropriate type of solvent cement, depending upon whether the cylindrical or conical type of socketed fitting is being used for a particular installation.

2 Normative reference

(standards.iteh.ai)

The following normative document contains provisions which, through reference in this text, constitute provisions of this part of ISO 727. For dated references, subsequent amendments to, or revisions of, this publication do not apply. However, parties to agreements based on this part of ISO 727 are encouraged to investigate the possibility of applying the most recent edition of the normative document indicated below. For undated references, the latest edition of the normative document referred to applies. Members of ISO and IEC maintain registers of currently valid International Standards.

ISO 161-2:1996, *Thermoplastics pipes for the conveyance of fluids — Nominal outside diameters and nominal pressures — Part 2: Inch-based series*

3 Terms and definitions

For the purposes of this part of ISO 727, the following terms and definitions apply.

3.1

cylindrical socket

plain socket having a generally cylindrical form with similar root and mouth dimensions

NOTE 1 In practice, such sockets are manufactured with a slight taper in order to assist in removing the moulded fitting from the moulding tool (see clause 6).

NOTE 2 The term parallel socket is used in some countries as a term equivalent to cylindrical socket.

3.2

conical socket

plain socket having a designed taper opening up from root to mouth, and having less clearance than a cylindrical socket

NOTE The term tapered socket is used in some countries as a term equivalent to conical socket.

3.3 mean inside diameter at mid-point of socket depth

d_{im}
arithmetic mean of two diameters measured at right angles to each other at the mid-point of the socket depth

4 Socket length

For cylindrical sockets, the minimum socket length L (Figure 1) shall conform to Table 1. For conical sockets (see Figure 2), the minimum socket length L shall conform to Table 2.

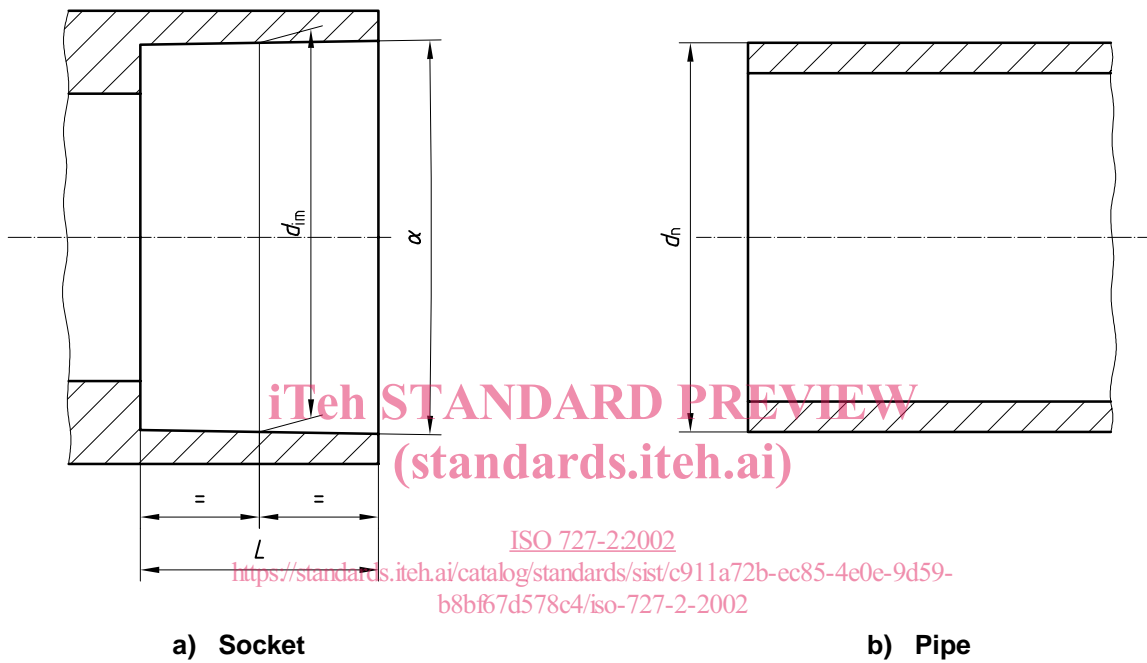

Figure 1 — Dimensions of cylindrical sockets

Table 1 — Dimensions of cylindrical sockets

Dimensions in millimetres

DN	Nominal outside diameter d_n	Minimum socket length ^a L	Mean inside diameter at mid-point of socket depth		Out-of-roundness max.
			min.	max.	
1/4	13,5	12,8	13,7	13,9	0,25
3/8	17,2	14,5	17,1	17,3	0,25
1/2	21,3	16,5	21,3	21,5	0,25
3/4	26,9	19,5	26,7	26,9	0,25
1	33,7	22,5	33,5	33,7	0,25
1 1/4	42,4	27	42,2	42,4	0,3
1 1/2	48,3	30	48,2	48,4	0,4
2	60,3	36	60,3	60,5	0,5
2 1/2	75,3	43,5	75,1	75,3	0,6
3	88,9	50,5	88,8	89,1	0,7
3 1/2	101,6	56,5	101,6	101,9	0,7
4	114,3	63	114,2	114,5	0,8
5	140,3	76	140,1	140,4	1
6	168,3	90	168,2	168,5	1,2
8	219,1	115,5	219,0	219,4	1,6
10	273	142,5	272,8	273,4	2
12	323,9	168	323,7	324,3	2,3

NOTE The values given in this table have been taken from BS 4346-1:1969.

^a The above-mentioned values for the minimum socket length related to cylindrical sockets made from PVC-U are calculated by the following equation: $L = 0,5d_n + 6$ mm, with a minimum socket length of 12 mm.

Due to the shrinkage behaviour of cylindrical sockets made from PVC-C and ABS, the socket lengths are calculated by the following equation: $L = 0,5d_n + 5$ mm.

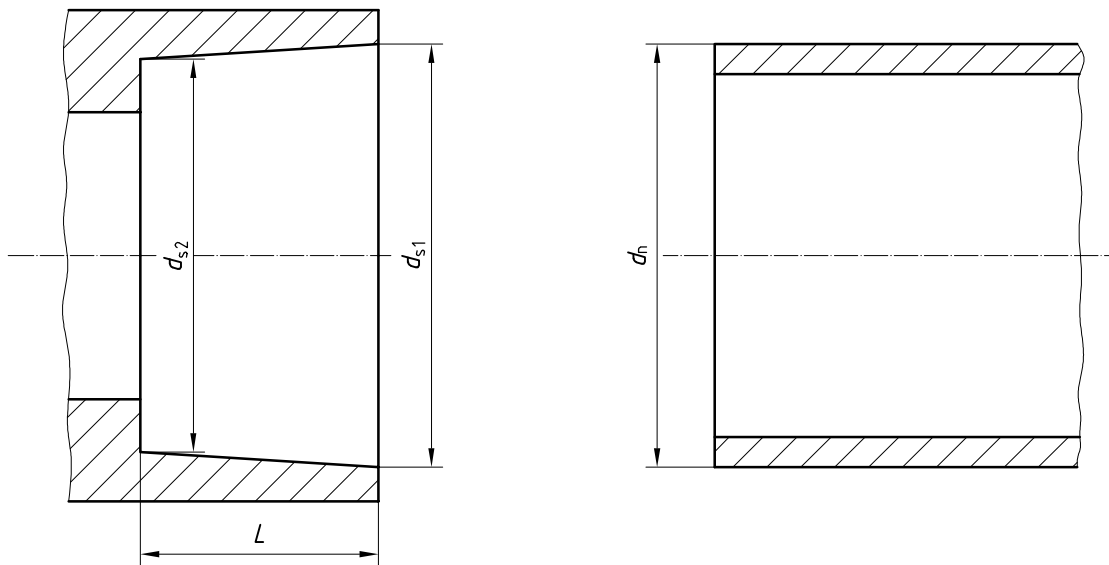

a) Socket

b) Pipe

Figure 2 — Dimensions of conical sockets

Table 2 — Dimensions of conical sockets
 (standards.itech.ai)

Dimensions in millimetres

DN	Nominal outside diameter d_n	Minimum socket length L	Mean inside diameter				Out-of-roundness max.
			Socket mouth d_{s1}		Socket root d_{s2}		
		min.	min.	max.	min.	max.	
1/4	13,5	15,9	13,92	14,12	13,51	13,71	0,2
3/8	17,2	19,1	17,35	17,55	16,94	17,14	0,2
1/2	21,3	22,2	21,44	21,64	21,13	21,33	0,2
3/4	26,9	25,4	26,77	26,97	26,47	26,67	0,25
1	33,7	28,6	33,53	33,79	33,14	33,40	0,25
1 1/4	42,4	31,8	42,29	42,55	41,91	42,17	0,3
1 1/2	48,3	34,9	48,41	48,71	47,96	48,26	0,3
2	60,3	38,1	60,48	60,78	60,02	60,32	0,3
2 1/2	75,3	44,5	73,20	73,56	72,67	73,03	0,4
3	88,9	47,6	89,11	89,51	88,5	88,9	0,4
3 1/2	101,6	54	101,81	102,21	101,2	101,6	0,4
4	114,3	57,2	114,53	114,99	113,84	114,30	0,4
5	140,3	66,7	141,56	142,06	140,8	141,3	0,8
6	168,3	76,2	168,55	169,11	167,72	168,28	0,9

NOTE The values given in this table have been taken from ASTM D 2467:2001.

5 Socket inside diameter

The mean inside diameter of a socket shall be in accordance with the requirements of Table 1 for cylindrical sockets or Table 2 for conical sockets, and is based on the dimensions for thermoplastics pipes included in ISO 161-2.

6 Taper of cylindrical sockets

The maximum included angle α of the socketed portion of a fitting shall not exceed $0^{\circ}40'$ for $d_n \leq 2\frac{1}{2}$ in and $0^{\circ}30'$ for $d_n \geq 3$ in.

7 Marking

The identification of the different types of plain socket (cylindrical and conical) shall be reflected in the minimum required marking for the relevant product and shall be included in the corresponding product standard.

iTeh STANDARD PREVIEW (standards.iteh.ai)

[ISO 727-2:2002](https://standards.iteh.ai/catalog/standards/sist/c911a72b-ec85-4e0e-9d59-b8bf67d578c4/iso-727-2-2002)

<https://standards.iteh.ai/catalog/standards/sist/c911a72b-ec85-4e0e-9d59-b8bf67d578c4/iso-727-2-2002>