



Designation: E 448 – 82 (Reapproved 2002)<sup>ε1</sup>

## Standard Practice for Scleroscope Hardness Testing of Metallic Materials<sup>1</sup>

This standard is issued under the fixed designation E 448; the number immediately following the designation indicates the year of original adoption or, in the case of revision, the year of last revision. A number in parentheses indicates the year of last reapproval. A superscript epsilon ( $\epsilon$ ) indicates an editorial change since the last revision or reapproval.

<sup>ε1</sup> NOTE—Section 3.1.5 was editorially updated in June 2003.

### 1. Scope

1.1 This practice covers the determination of the Scleroscope<sup>2</sup> hardness of metallic materials (Part A), the verification of Scleroscope hardness instruments (Part B), and the calibration of standardized hardness test blocks (Part C).

1.2 The values stated in SI units are to be regarded as the standard. The values given in parentheses are for information only.

1.3 This standard does not purport to address all of the safety problems, if any, associated with its use. It is the responsibility of the user of this standard to establish appropriate safety and health practices and determine the applicability of regulatory limitations prior to use.

### 2. Referenced Documents

#### 2.1 ASTM Standards:

A 427 Specification for Wrought Alloy Steel Rolls for Cold and Hot Reduction<sup>3</sup>

E 140 Hardness Conversion Tables for Metals (Relationship Among Brinell Hardness, Vickers Hardness, Rockwell Hardness, Rockwell Superficial Hardness, and Knoop Hardness, and Scleroscope Hardness)<sup>4</sup>

### 3. Terminology

#### 3.1 Definitions:

3.1.1 *calibration*—determination of the values of the significant parameters by comparison with values indicated by a reference instrument or by a set of reference standards.

3.1.2 *forged roll Scleroscope hardness number (HFRSc or HFRSd)*<sup>5</sup>—a number related to the height of rebound of a diamond-tipped hammer dropped on a forged steel roll. It is measured on a scale determined by dividing into 100 units the

<sup>1</sup> This practice is under the jurisdiction of ASTM Committee E28 on Mechanical Testing and is the direct responsibility of E28.06 on Indentation Hardness Testing. Current edition approved July 30, 1982. Published December 1982. Originally published as E 448–72. Last previous edition E 448–72 (1977).

<sup>2</sup> Registered trademark of the Shore Instrument & Mfg. Co., Inc.

<sup>3</sup> *Annual Book of ASTM Standards*, Vol 01.05.

<sup>4</sup> *Annual Book of ASTM Standards*, Vol 03.01.

<sup>5</sup> The conversion from Forged Roll “C” Scleroscope hardness to Vickers hardness contained in Specification A 427 and to Rockwell C hardness contained in Standard E 140 are presently the only Scleroscope hardness conversions in ASTM standards.

average rebound of a hammer from a forged steel roll of accepted maximum hardness.

NOTE 1—The flat striking surface of the hammer in the forged roll Scleroscope is slightly larger than the corresponding surface in the Scleroscope described in 3.1.3 (see Fig. 1). Hence the forged roll

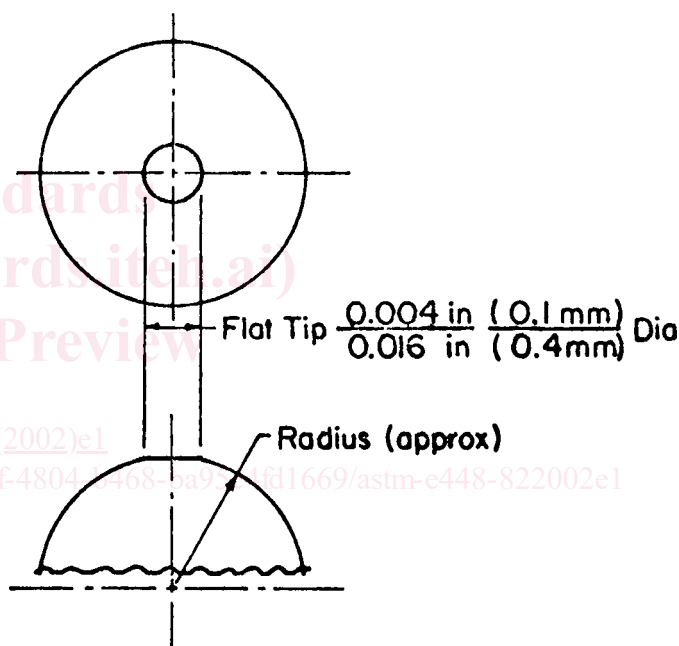

FIG. 1 Profile of Scleroscope Diamond Showing Range of Diameters of Flat Tip

Scleroscope yields correspondingly higher hardness numbers.

3.1.3 *Scleroscope hardness number (HSc or HSd)*—a number related to the height of rebound of a diamond-tipped hammer dropped on the material being tested. It is measured on a scale determined by dividing into 100 units the average rebound of the hammer from a quenched (to maximum hardness) and untempered high carbon water-hardening tool steel test block of AISI W-5.

3.1.4 *Scleroscope hardness test*—a dynamic indentation hardness test using a calibrated instrument that drops a diamond-tipped hammer (Note 2) from a fixed height onto the

surface of the material under test. The height of rebound of the hammer is a measure of the hardness of the material.

NOTE 2—An all-steel “Magnifier Hammer” that yielded a greater spread in hardness readings on soft nonferrous metals has been available. This hammer has become obsolete and, hence, is not considered in this practice.

3.1.5 *verification*—confirmation by examination and provision of evidence that an instrument, material, reference or standard is in conformance with a specification.

## GENERAL DESCRIPTION OF INSTRUMENTS AND TEST PROCEDURE FOR SCLEROSCOPE HARDNESS TEST

### 4. Apparatus

4.1 The instrument used for determining Scleroscope hardness numbers is supplied in two models designated Model C and Model D.<sup>6</sup>

4.2 *Scleroscope Model C*—This model consists of a vertically disposed barrel containing a precision bore glass tube. A scale, graduated from 0 to 140, is set behind and is visible through the glass tube. A pneumatic actuating head, affixed to the top of the barrel, is manually operated by a rubber bulb and tube. A hammer drops from a specified height and rebounds within the glass tube.

4.3 *Scleroscope Model D*—This model is known as the Dial Recording Scleroscope. It consists of a vertically disposed barrel containing a clutch to arrest the hammer at maximum height of rebound. This is made possible by using a hammer which is longer and heavier than the hammer in the Model C Scleroscope, and which develops the same striking energy in dropping through a shorter distance. A number of supporting devices are available with this instrument and it is recommended that one of these be used (see section 4.5).

#### 4.4 *Diamond-Tipped Hammers:*

4.4.1 There are two sizes of diamond-tipped hammers commonly used in the Scleroscope hardness instruments. These are the small hammer used in the Model C instrument and the larger hammer used in the Model D instrument.

4.4.2 The following dimensions are applicable to the diamond-tipped hammers:

		Model C
Diameter		0.234 in. (5.94 mm)
Mass		2.300 ± 0.500 g
Over-all length		0.815 to 0.840 in. (20.7 to 21.3 mm)
Distance hammer falls		9.890 + 0.005, -0.015 in. (251.2 + 0.1, -0.4 mm)
		Model D
Diameter		0.3125 in. (7.94 mm)
Mass		36.0 ± 2.0 g
Over-all length		3.990 to 4.010 in. (101.33 to 104.10 mm)
Distance hammer falls		0.704 + 0.017, -0.021 in. (17.9 + 0.4, -0.5 mm)

4.4.3 The geometry of the diamond tip is of significance only at its ultimate extremity because of the limited penetration of the diamond into the material being tested. Such penetration is about 0.001 in. (0.025 mm) on mild steel and about 0.0005 in. (0.013 mm) on hardened tool steel. Further, the variation in hardness of commercially available industrial diamonds has a

significant effect on the readings of a rebound-type hardness instrument. Consequently, the geometry of the diamond must be shaped to produce a correct reading on reference bars of known hardness. In the forged roll Scleroscope the diamond tip is specifically dimensioned to produce a correct reading on a forged-steel roll of known hardness. In profile, the diamond is convex, having an approximate radius terminated by a flat striking surface, as shown in Fig. 1. The flat striking surface is approximately circular and from 0.004 to 0.016 in. (0.1 to 0.4 mm) in diameter, depending on the type of instrument and the hardness and other physical characteristics of the diamond.

4.5 *Supporting Devices*—The three supporting devices used most frequently with the Scleroscope are (a) the clamping stand, (b) the swing arm and post, and (c) the roll-testing stand.

### 5. Test Specimens

5.1 *Form*—Specimens used in Scleroscope testing vary greatly with respect to size and shape. Smaller specimens may be tested in the clamping stand which has a jaw capacity of 3 in. (76 mm) high by 2½ in. (64 mm) deep. Large specimens, beyond the jaw capacity of the clamping stand, may be tested with the instrument mounted on the swing arm and post or the roll-testing stand. The swing arm and post has a height and reach capacity of 9 in. (230 mm) and 14 in. (360 mm), respectively. The roll-testing stand may be used for mounting the instrument on cylindrical specimens with a diameter of 2½ in. (64 mm) and upward without limit. The roll-testing stand may also be used for mounting the instrument on flat, horizontal surfaces with a minimum perimetric dimension of 3 by 5 in. (76 by 130 mm). The Model C Scleroscope may be used free hand for testing specimens with a minimum mass of 5 lb (2.3 kg). It is not recommended that the Model D Scleroscope be used free hand.

5.2 *Thickness*—Thin strips or sheets may be tested, with some limitations, but only when the Scleroscope is mounted in the clamping stand. Ideally, the sheet should be flat and without undulation. If the sheet material is bowed, the concave side should be up to preclude any possibility of erroneous readings due to spring effect. The minimum thicknesses of sheet in various categories that may be tested are as follows:

Material	Thickness	
	in.	mm
Hard steel	0.005 to 0.006	0.13 to 0.15
Half-hard brass strip	0.010	0.25
Cold-rolled steel	0.010	0.25
Annealed-brass sheet	0.015	0.38

<sup>6</sup> Model C and D Scleroscopes are manufactured by the Shore Instrument and Manufacturing Co., Inc., Jamaica, NY.