

---

---

**Test conditions for surface grinding  
machines with horizontal grinding wheel  
spindle and reciprocating table — Testing  
of the accuracy —**

Part 1:

**Machines with a table length of up to  
1 600 mm**

iTeh STANDARD PREVIEW  
(standards.iteh.ai)

*Conditions d'essai des machines à rectifier les surfaces planes, à broche  
porte-meules à axe horizontal — Contrôle de la précision —*

<https://standards.iteh.ai/catalog/standards/sis/75dc6677-44c7-46b9-b93e->

*Partie 1: Machines avec une table jusqu'à 1 600 mm de long*



**PDF disclaimer**

This PDF file may contain embedded typefaces. In accordance with Adobe's licensing policy, this file may be printed or viewed but shall not be edited unless the typefaces which are embedded are licensed to and installed on the computer performing the editing. In downloading this file, parties accept therein the responsibility of not infringing Adobe's licensing policy. The ISO Central Secretariat accepts no liability in this area.

Adobe is a trademark of Adobe Systems Incorporated.

Details of the software products used to create this PDF file can be found in the General Info relative to the file; the PDF-creation parameters were optimized for printing. Every care has been taken to ensure that the file is suitable for use by ISO member bodies. In the unlikely event that a problem relating to it is found, please inform the Central Secretariat at the address given below.

**iTeh STANDARD PREVIEW**  
**(standards.iteh.ai)**

ISO 1986-1:2001

<https://standards.iteh.ai/catalog/standards/sist/73dc6677-44c7-4bf9-b93e-3ca098f89d59/iso-1986-1-2001>

© ISO 2001

All rights reserved. Unless otherwise specified, no part of this publication may be reproduced or utilized in any form or by any means, electronic or mechanical, including photocopying and microfilm, without permission in writing from either ISO at the address below or ISO's member body in the country of the requester.

ISO copyright office  
Case postale 56 • CH-1211 Geneva 20  
Tel. + 41 22 749 01 11  
Fax + 41 22 749 09 47  
E-mail [copyright@iso.ch](mailto:copyright@iso.ch)  
Web [www.iso.ch](http://www.iso.ch)

Printed in Switzerland

## Contents

Page

Foreword.....	iv
1 Scope .....	1
2 Normative reference .....	1
3 Terminology and designation of axes .....	1
4 Preliminary remarks .....	3
4.1 Measuring units .....	3
4.2 Reference to ISO 230-1 .....	3
4.3 Testing sequence.....	3
4.4 Tests to be performed .....	3
4.5 Measuring instruments .....	3
4.6 Minimum tolerance .....	3
4.7 Machining tests.....	3
4.8 Diagrams.....	3
5 Geometric tests.....	4
5.1 Linear axes .....	4
5.2 Table.....	8
5.3 Wheel spindle.....	11
6 Machining tests.....	15
Bibliography .....	17

[ISO 1986-1:2001](https://standards.iteh.ai/catalog/standards/sist/73dc6677-44c7-4bf9-b93e-3ca098f89d59/iso-1986-1-2001)

<https://standards.iteh.ai/catalog/standards/sist/73dc6677-44c7-4bf9-b93e-3ca098f89d59/iso-1986-1-2001>

## Foreword

ISO (the International Organization for Standardization) is a worldwide federation of national standards bodies (ISO member bodies). The work of preparing International Standards is normally carried out through ISO technical committees. Each member body interested in a subject for which a technical committee has been established has the right to be represented on that committee. International organizations, governmental and non-governmental, in liaison with ISO, also take part in the work. ISO collaborates closely with the International Electrotechnical Commission (IEC) on all matters of electrotechnical standardization.

International Standards are drafted in accordance with the rules given in the ISO/IEC Directives, Part 3.

Draft International Standards adopted by the technical committees are circulated to the member bodies for voting. Publication as an International Standard requires approval by at least 75 % of the member bodies casting a vote.

Attention is drawn to the possibility that some of the elements of this part of ISO 1986 may be the subject of patent rights. ISO shall not be held responsible for identifying any or all such patent rights.

International Standard ISO 1986-1 was prepared by Technical Committee ISO/TC 39, *Machine tools*, Subcommittee SC 2, *Test conditions for metal cutting machine tools*.

This first edition of ISO 1986-1 cancels and replaces ISO 1986:1985, of which it constitutes a technical revision.

ISO 1986 consists of the following parts, under the general title *Test conditions for surface grinding machines with horizontal grinding wheel spindle and reciprocating table — Testing of the accuracy*:

- Part 1: Machines with a table length of up to 1 600 mm
- Part 2: Machines with a table length longer than 1 600 mm

# Test conditions for surface grinding machines with horizontal grinding wheel spindle and reciprocating table — Testing of the accuracy —

## Part 1: Machines with a table length of up to 1 600 mm

### 1 Scope

This part of ISO 1986 specifies, with reference to ISO 230-1, both geometric and machining tests on general purpose and normal accuracy surface grinding machines with reciprocating table up to 1 600 mm table length and horizontal grinding wheel spindle. It also specifies the applicable tolerances corresponding to the above-mentioned tests.

NOTE For machines with table length larger than 1 600 mm, ISO 1986-2 is being prepared.

It is not applicable to surface grinding machines with fixed or rotating tables or to machines having longitudinal traverse of the wheelhead.

This part of ISO 1986 deals only with the verification of the accuracy of the machine; it does not apply to the testing of the machine operation (vibrations, abnormal noises, stick-slip motion of components, etc.), nor to the machine characteristics (such as speeds, feeds, etc.), which should generally be checked before testing the accuracy.

This part of ISO 1986 provides the terminology used for the principal components of the machine and indicates the designation of the axes in accordance with reference to ISO 841.

### 2 Normative reference

The following normative document contain provisions which, through reference in this text, constitute provisions of this part of ISO 1986. For dated references, subsequent amendments to, or revisions of, any of these publications do not apply. However, parties to agreements based on this part of ISO 1986 are encouraged to investigate the possibility of applying the most recent edition of the normative document indicated below. For undated references, the latest edition of the normative document referred to applies. Members of ISO and IEC maintain registers of currently valid International Standards.

ISO 230-1:1996, *Test code for machine tools — Part 1: Geometric accuracy of machines operating under no-load or finishing conditions*

### 3 Terminology and designation of axes

See Figure 1 and Table 1.

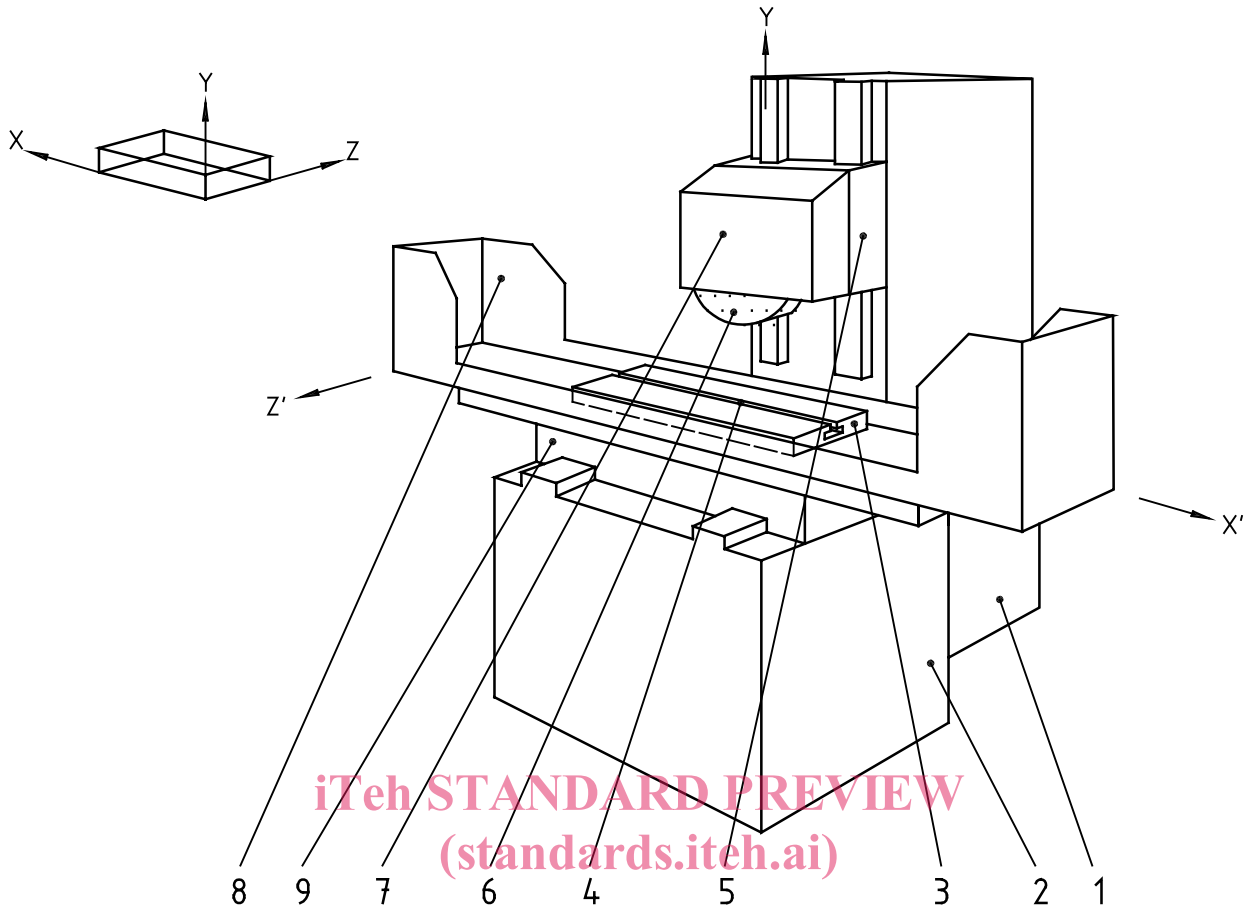

ISO 1986-1:2001  
<https://standards.iteh.ai/catalog/standards/sist/73dc6677-44c7-4bf9-b93e-3ca098f89d59/iso-1986-1-2001>  
**Figure 1**

**Table 1**

Repère	English	French	German	Italian
1	Column	Montant	Ständer	Montante
2	Bed	Banc	Bett	Banco
3	Table	Table	Tisch	Tavola
4	Reference T-slot	Rainure en T de positionnement	Richtnut	Scanalatura di riferimento
5	Wheelhead	Poupée porte-meule	Schleifspindelstock	Testa porta-mola
6	Grinding wheel	Outil à rectifier	Schleifwerkzeug	Mola
7	Wheel guard	Carter de protection	Schutzhaube	Riparo mola
8	Splash guard	Protection	Fangschutz	Riparo para-spruzzi
9	Saddle	Chariot transversal	Schlitten	Sella

NOTE In addition to terms used in the two of the three official ISO languages (English and French), this table gives equivalent terms in German and Italian published under the responsibility of the member bodies for Germany (DIN) and Italy (UNI). However, only the terms given in the official languages can be considered as ISO terms.

## 4 Preliminary remarks

### 4.1 Measuring units

In this part of ISO 1986, all linear dimensions, deviations and corresponding tolerances are expressed in millimetres; angular dimensions are expressed in degrees, and angular deviations and the corresponding tolerances are expressed primarily in ratios, but in some cases microradians or arcseconds may also be used for clarification purposes. The equivalence of the following expressions should be kept in mind:

$$0,010/1\ 000 = 10\ \mu\text{rad} \approx 2''$$

### 4.2 Reference to ISO 230-1

To apply this part of ISO 1986, reference shall be made to ISO 230-1, especially for the installation of the machine before testing, warming up of the spindle and other moving components, description of measuring methods and recommended accuracy of testing equipment.

In the "Observations" block of the tests described in clauses 5 and 6, the instructions are followed by a reference to the corresponding clause in ISO 230-1, in cases where the test concerned is in compliance with the specifications of ISO 230-1.

### 4.3 Testing sequence

The sequence in which the tests are presented in this part of ISO 1986 in no way defines the practical order of testing. In order to make the mounting of instruments or gauging easier, tests may be performed in any order.

### 4.4 Tests to be performed

When testing a machine, it is not always necessary nor possible to carry out all the tests described in this part of ISO 1986. When the tests are required for acceptance purposes, it is up to the user to choose, in agreement with the supplier/manufacturer, those tests relating to the components and/or the properties of the machine which are of interest. These tests are to be clearly stated when ordering a machine.

### 4.5 Measuring instruments

The measuring instruments indicated in the tests described in clauses 5 and 6 are examples only. Other instruments measuring the same quantities and having at least the same accuracy may be used. Dial gauges or other linear displacement probes shall have a resolution of 0,001 mm.

### 4.6 Minimum tolerance

When the tolerance for a geometric test is established for a measuring length different from that given in this part of ISO 1986 (see 2.311 of ISO 230-1:1993), it shall be taken into consideration that the minimum value of tolerance is 0,001 mm.

### 4.7 Machining tests

Machining tests shall be made with finishing cuts only, not with roughing cuts which are liable to generate appreciable cutting forces.

### 4.8 Diagrams

For reasons of simplicity, the diagrams in this part of ISO 1986 illustrate only one type of machine.

5 Geometric tests

5.1 Linear axes

<p><b>Object</b></p>		<p><b>G1</b></p>
<p>Checking of straightness of the longitudinal (X-axis) movement of the table:</p> <p>a) in the vertical XY-plane;  b) in the horizontal ZX-plane.</p>		
<p><b>Diagram</b></p> <p style="text-align: center;">a) <span style="margin-left: 200px;">b)</span></p>		
<p><b>Tolerance</b></p> <p>For a) and b)</p> <p>0,010 for a measuring length up to 1 000</p> <p>0,016 for a measuring length exceeding 1 000</p>	<p><b>Measured deviation</b></p> <p>a)</p> <p>b)</p>	
<p><b>Measuring instruments</b></p> <p>Straightedge and dial gauge, alignment telescope, laser interferometer or taut wire, and microscope [for b) only]</p>		
<p><b>Observations and references to ISO 230-1:1996</b> <span style="float: right;">5.232.1</span></p> <p>Adjust the straightedge to obtain similar readings at each end of the measuring length.</p> <p>The dial gauge support shall be placed on a fixed part of the wheelhead, the stylus touching the straightedge.</p>		

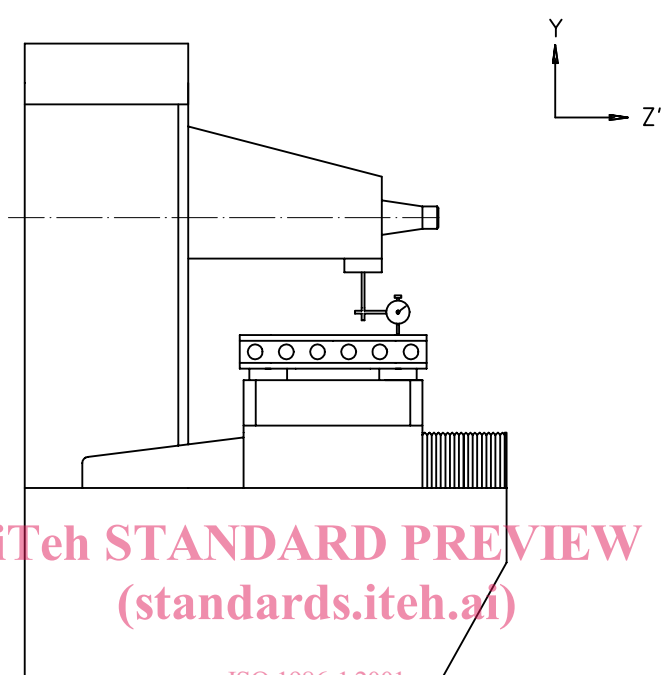

<p><b>Object</b></p>	<p><b>G2</b></p>
<p>Checking of the straightness of the transverse movement of the saddle or column or wheelhead (Z-axis) in the vertical YZ-plane.</p>	
<p><b>Diagram</b></p> 	
<p><b>Tolerance</b></p> <p>0,010 for a measuring length of up to 500</p> <p>0,015 for a measuring length exceeding 500</p> <p>Local tolerance: 0,005 over any measuring length of 300</p>	<p><b>Measured deviation</b></p>
<p><b>Measuring instruments</b></p> <p>Straightedge and dial gauge, alignment telescope or laser interferometer</p>	
<p><b>Observations and references to ISO 230-1:1996</b> <span style="float: right;">5.232.1</span></p> <p>Adjust the straightedge to obtain similar readings at each end of the measuring length.</p> <p>The dial gauge support shall be placed on a fixed part of the wheelhead, the stylus touching a straightedge.</p>	

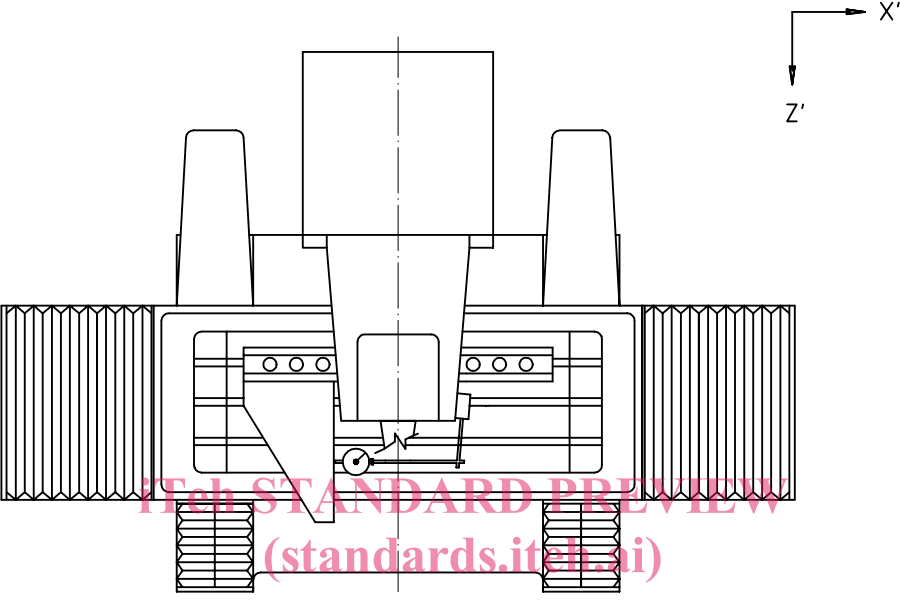
<p><b>Object</b></p>	<p><b>G3</b></p>
<p>Checking of squareness between the longitudinal (X-axis) movement of the table and the transverse movement (Z-axis) of the saddle or column or wheelhead.</p>	
<p><b>Diagram</b></p> 	
<p><b>Tolerance</b></p> <p>0,03 for any measuring length of 300</p>	<p><b>Measured deviation</b></p>
<p><b>Measuring instruments</b></p> <p>Straightedge, square and dial gauge</p>	
<p><b>Observations and references to ISO 230-1:1996</b> 5.522.4</p> <p>The dial gauge shall be placed on a fixed part of the wheelhead.</p> <p>Place a straightedge parallel to the longitudinal movement of the table and then place the table in its central position.</p> <p>Place a square in contact with the straightedge.</p> <p>Check the transverse movement of the saddle or column or wheelhead.</p>	

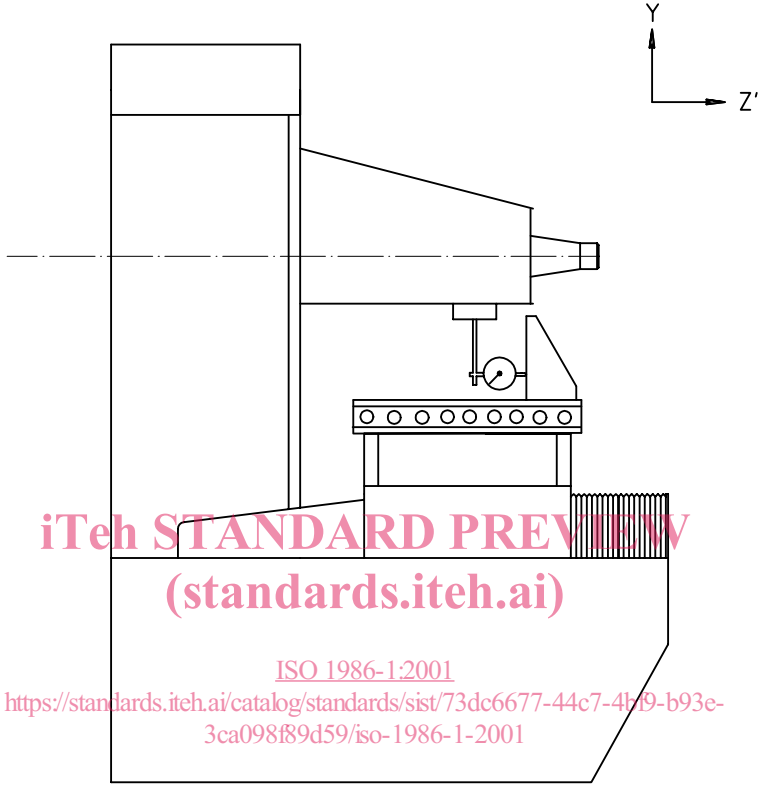
<p><b>Object</b></p>	<p><b>G4</b></p>
<p>Checking of the squareness between the vertical movement of the wheelhead (Y-axis) and the transverse movement of saddle or column or wheelhead (Z-axis).</p>	
<p><b>Diagram</b></p> 	
<p><b>Tolerance</b></p> <p>0,04 for a measuring length of 300</p>	<p><b>Measured deviation</b></p>
<p><b>Measuring instruments</b></p> <p>Dial gauge and square, straightedge and gauge blocks</p>	
<p><b>Observations and references to ISO 230-1:1996</b> <span style="float: right;">5.522.4</span></p> <p>The dial gauge shall be placed on a fixed part of the wheelhead.</p> <p>Place a straightedge parallel to the transverse movement of the table and then place the table in its central position.</p> <p>Place a square in contact with the straightedge.</p> <p>Check the vertical movement of the wheelhead.</p>	