

ETSI TS 102 624-3 V1.2.1 (2009-11)

Technical Specification

Broadband Radio Access Networks (BRAN); HiperMAN; Conformance Testing for the Network layer of HiperMAN/WiMAX terminal devices; Part 3: Abstract Test Suite (ATS)



iTeh STANDARD PREVIEW
(standards.iteh.ai)

Full standard:
<https://standards.iteh.ai/catalog/standards/sist/767dde9a-7d2f-41f2-89b1-1dc3c3c3c911/etsi-ts-102-624-3-v1.2.1-2009-11>



Reference

 RTS/BRAN-004T010-3

Keywords

 ATS, HiperMAN, layer 3, terminal, testing

ETSI

650 Route des Lucioles
F-06921 Sophia Antipolis Cedex - FRANCE

Tel.: +33 4 92 94 42 00 Fax: +33 4 93 65 47 16

Siret N° 348 623 562 00017 - NAF 742 C
Association à but non lucratif enregistrée à la
Sous-Préfecture de Grasse (06) N° 7803/88

Important notice

Individual copies of the present document can be downloaded from:

<http://www.etsi.org>

The present document may be made available in more than one electronic version or in print. In any case of existing or perceived difference in contents between such versions, the reference version is the Portable Document Format (PDF). In case of dispute, the reference shall be the printing on ETSI printers of the PDF version kept on a specific network drive within ETSI Secretariat.

Users of the present document should be aware that the document may be subject to revision or change of status. Information on the current status of this and other ETSI documents is available at

<http://portal.etsi.org/tb/status/status.asp>

If you find errors in the present document, please send your comment to one of the following services:

http://portal.etsi.org/chaicor/ETSI_support.asp

Copyright Notification

No part may be reproduced except as authorized by written permission.
The copyright and the foregoing restriction extend to reproduction in all media.

© European Telecommunications Standards Institute 2009.

© WIMAX Forum 2009.

All rights reserved.

DECT™, **PLUGTESTS™**, **UMTS™**, **TIPHON™**, the TIPHON logo and the ETSI logo are Trade Marks of ETSI registered for the benefit of its Members.

3GPP™ is a Trade Mark of ETSI registered for the benefit of its Members and of the 3GPP Organizational Partners.

LTE™ is a Trade Mark of ETSI currently being registered for the benefit of its Members and of the 3GPP Organizational Partners.

GSM® and the GSM logo are Trade Marks registered and owned by the GSM Association.

Contents

Intellectual Property Rights	6
Foreword.....	6
1 Scope	7
2 References	7
2.1 Normative references	7
2.2 Informative references.....	10
3 Definitions and abbreviations.....	10
3.1 Definitions.....	10
3.2 Abbreviations	10
4 Abstract Test Method (ATM).....	11
4.1 Test architecture	11
4.1.1 Points of Observation and Control.....	11
4.1.2 Architectural Requirements	13
4.1.2.1 Reuse of DLC-TTCN.....	13
4.1.2.2 Security test group	14
4.1.2.3 IPv4 test groups.....	14
4.1.2.4 IPv6 test groups.....	15
4.1.2.5 Miscellaneous requirements.....	15
4.1.2.6 OTA test group.....	16
4.1.3 Test method	16
4.1.3.1 What is notional upper tester?.....	16
4.1.4 Test machine operational parameters.....	16
4.1.5 Test machine configuration.....	17
4.1.5.1 Presentation.....	17
4.1.5.2 Test suite TTCN-3 development concept.....	18
4.1.6 Re-use of existing test specifications.....	18
4.1.7 Test architecture.....	19
4.1.7.1 NCT specific part.....	20
4.1.7.2 DLC-TTCN extension part.....	21
4.1.7.3 Requirements accomplishment.....	21
4.2 Description of the ports and their associated primitives.....	21
4.2.1 The MacMessagePort type.....	22
4.2.1.1 Description	22
4.2.1.2 Primitives of the MacMsg port.....	22
4.2.1.3 NCT specific extension.....	22
4.2.2 The MacBcMessagePort type	22
4.2.2.1 Description	22
4.2.2.2 Primitives of the MacMsg port.....	22
4.2.2.3 NCT specific extension.....	22
4.2.3 The MacPduPort type	22
4.2.3.1 Description	22
4.2.3.2 Primitives of the MacPdu port	22
4.2.3.3 NCT specific extension	23
4.2.4 The PhyPort type	23
4.2.4.1 Description	23
4.2.4.2 Primitives of the Phy port	23
4.2.4.3 NCT specific extension.....	23
4.2.5 The TAPort type	23
4.2.5.1 Description	23
4.2.5.2 Primitives of the TA port	23
4.2.5.3 NCT specific extension.....	23
4.2.6 The NwIpv4Port type.....	23
4.2.6.1 Description	23
4.2.6.2 Primitives of the NwIpv4 Port	24

4.2.7	The NwIpv6Port type.....	25
4.2.7.1	Description	25
4.2.7.2	Primitives of the NwIpv6 port.....	25
4.2.8	The MacPkmv2Port type	26
4.2.8.1	Description	26
4.2.8.2	Primitives of the MacPkmv2 port	26
4.3	Port mapping rules.....	27
5	Untestable Test Purposes (TP)	28
6	ATS conventions	28
6.1	Testing conventions.....	28
6.1.1	Testing States.....	28
6.1.2	HiperMAN default values: Reception and transmission at ATS level.....	29
6.1.3	IPv4 and UDP protocol headers: Reception and transmission at ATS level.....	29
6.1.4	Network protocol messages: Reception and transmission at ATS level	30
6.1.5	EAP-TTLS encrypted tunnel: Reception and transmission at ATS level	33
6.1.6	NCT CODECS Implementation (Informative)	33
6.1.7	Templates.....	33
6.1.8	Functions	33
6.2	Naming conventions.....	34
6.2.1	General guidelines	34
6.2.2	Test Case (TC) identifier	35
6.3	Service Flow parameter support.....	35
6.3.1	CsSpecification support	36
6.3.2	DataDeliveryServiceType.....	36
6.4	Dispatching of test cases over TTCN modules.....	36
6.5	Reuse of TTCN modules.....	36
7	External functions	37
8	Test strategies.....	37
8.1	Processing of Pkmv2 messages	37
8.2	Processing of IP packets	39
8.3	Processing of EAP-TTLS AVPs	41
8.4	IP Fragmentation testing	43
8.5	Processing OTA messages	43
Annex A (normative):	WiMAX/HiperMAN NCT Abstract Test Suite (ATS)	46
A.1	The TTCN-3 Module.....	46
Annex B (normative):	WiMAX/HiperMAN NCT Partial PIXIT proforma for IUT MS	47
Annex C (normative):	WiMAX/HiperMAN NCTR Proforma for IUT MS	48
C.1	Identification summary.....	48
C.1.1	Protocol conformance test report.....	48
C.1.2	IUT identification	48
C.1.3	Testing environment.....	48
C.1.4	Limits and reservation	49
C.1.5	Comments.....	49
C.2	IUT Conformance status	49
C.3	Static conformance summary	49
C.4	Dynamic conformance summary.....	50
C.5	Static conformance review report.....	50
C.6	Test campaign report.....	51
C.7	Observations.....	52
Annex D (normative):	HTML documentation.....	53

Annex E (informative):	Bibliography	54
History		55

iTeh STANDARD PREVIEW
(standards.iteh.ai)

Full standard:
<https://standards.iteh.ai/catalog/standards/sist/767dde9a-7d2f-41f2-89b1-1dc3e3c3e911/etsi-ts-102-624-3-v1.2.1-2009-11>

Intellectual Property Rights

IPRs essential or potentially essential to the present document may have been declared to ETSI. The information pertaining to these essential IPRs, if any, is publicly available for **ETSI members and non-members**, and can be found in ETSI SR 000 314: "*Intellectual Property Rights (IPRs); Essential, or potentially Essential, IPRs notified to ETSI in respect of ETSI standards*", which is available from the ETSI Secretariat. Latest updates are available on the ETSI Web server (<http://webapp.etsi.org/IPR/home.asp>).

Pursuant to the ETSI IPR Policy, no investigation, including IPR searches, has been carried out by ETSI. No guarantee can be given as to the existence of other IPRs not referenced in ETSI SR 000 314 (or the updates on the ETSI Web server) which are, or may be, or may become, essential to the present document.

Foreword

This Technical Specification (TS) has been produced by ETSI Technical Committee Broadband Radio Access Networks (BRAN).

The present document was developed on the basis of the Abstract Test Suite (ATS) specification for HiperMAN systems that was in the advanced stage of development when the work was reoriented to produce joint HiperMAN/WiMAX specifications.

The present document is part 3 of a multi-part deliverable covering HiperMAN; Conformance Testing for Network layer of the WiMAX/HiperMAN terminal devices, as identified below:

- Part 1: "Protocol Implementation Conformance Statement (PICS) proforma";
- Part 2: "Test Suite Structure and Test Purposes (TSS&TP)";
- Part 3: "Abstract Test Suite (ATS)".**

1 Scope

The present document contains the Abstract Test Suite (ATS) to test BRAN HiperMAN/WiMAX terminal devices for conformance across WiMAX networks.

The objective of the present document is to provide a basis for conformance tests for WiMAX terminal equipment giving a high probability of air interface inter-operability between different manufacturers' WiMAX equipment.

The ISO standard for the methodology of conformance testing (ISO/IEC 9646-1 [39] and ISO/IEC 9646-2 [40]) as well as the ETSI rules for conformance testing (ETS 300 406 [35]) are used as a basis for the test methodology.

Annex A provides the Tree and Tabular Combined Notation (TTCN) part of the ATS.

Annex B provides the Partial Protocol Implementation Extra Information for Testing (PIXIT) Proforma of the SS side ATS.

Annex C provides the Protocol Conformance Test Report (PCTR) Proforma of the MS side ATS.

2 References

References are either specific (identified by date of publication and/or edition number or version number) or non-specific.

- For a specific reference, subsequent revisions do not apply.
- Non-specific reference may be made only to a complete document or a part thereof and only in the following cases:
 - if it is accepted that it will be possible to use all future changes of the referenced document for the purposes of the referring document;
 - for informative references.

Referenced documents which are not found to be publicly available in the expected location might be found at <http://docbox.etsi.org/Reference>.

NOTE: While any hyperlinks included in this clause were valid at the time of publication ETSI cannot guarantee their long term validity.

2.1 Normative references

The following referenced documents are indispensable for the application of the present document. For dated references, only the edition cited applies. For non-specific references, the latest edition of the referenced document (including any amendments) applies.

- [1] WiMAX Forum (Release 1.5): "WiMAX Forum Network Architecture, Stage 2: Architecture Tenets, Reference Model and Reference Points, Base Specification".
- [2] WiMAX Forum (Release 1.5): "WiMAX Forum Network Architecture, Stage 3: Detailed Protocols and Procedures, Base Specification".
- [3] Void.
- [4] ETSI TS 102 624-2: "Broadband Radio Access Networks (BRAN); HiperMAN; onformance Testing for the Network layer of HiperMAN/WiMAX terminal devices; Part 2: Test Suite Structure and Test Purposes (TSS&TP)".
- [5] ETSI TS 102 545-3: "Broadband Radio Access Networks (BRAN); HiperMAN; Conformance Testing for WiMAX/HiperMAN 1.3.1 Part 3: Abstract Test Suite (ATS)".

- [6] IEEE 802.16e-2005: "IEEE Standard for Local and metropolitan area networks - Part 16: Air Interface for Fixed and Mobile Broadband Wireless Access Systems. Amendment 2: Physical and Medium Access Control Layers for Combined Fixed and Mobile Operation in Licensed Bands and Corrigendum 1".
- [7] IEEE 802.16g-2007: "IEEE Standard for Local and Metropolitan Area Networks - Part 16: Air Interface for Fixed and Mobile Broadband Wireless Access Systems - Amendment 3: Management Plane Procedures and Services".

NOTE: Available at <http://standards.ieee.org/getieee802/802.16.html>.

- [8] IETF RFC 768 (August 1980): "User Datagram Protocol".
- [9] IETF RFC 791 (September 1981): "Internet Protocol".
- [10] IETF RFC 792 (September 1981): "Internet Control Message Protocol".
- [11] Void.
- [12] IETF RFC 1112 (August 1989): "Host Extensions for IP Multicasting".
- [13] IETF RFC 1256 (September 1991): "ICMP Router Discovery Messages".
- [14] IETF RFC 2131 (March 1997): "Dynamic Host Configuration Protocol".
- [15] IETF RFC 2132 (March 1997): "DHCP Options and BOOTP Vendor Extensions".
- [16] IETF RFC 2460 (December 1998): "Internet Protocol, Version 6 (IPv6) Specification".
- [17] IETF RFC 2794 (March 2000): "Mobile IP Network Access Identifier Extension for IPv4".
- [18] IETF RFC 3315 (July 2003): "Dynamic Host Configuration Protocol for IPv6 (DHCPv6)".
- [19] IETF RFC 3344 (August 2002): "IP Mobility Support for IPv4".
- [20] IETF RFC 3543 (August 2003): "Registration Revocation in Mobile IPv4".
- [21] IETF RFC 3748 (June 2004): "Extensible Authentication Protocol (EAP)".
- [22] IETF RFC 3775 (June 2004): "Mobility Support in IPv6".
- [23] IETF RFC 3846 (June 2004): "Mobile IPv4 Extension for Carrying Network Access Identifiers".
- [24] IETF RFC 4187 (January 2006): "Extensible Authentication Protocol Method for 3rd Generation Authentication and Key Agreement (EAP-AKA)".
- [25] IETF RFC 4283 (November 2005): "Mobile Node Identifier Option for Mobile IPv6 (MIPv6)".
- [26] IETF RFC 4285 (January 2006): "Authentication Protocol for Mobile IPv6".
- [27] IETF RFC 4433 (March 2006): "Mobile IPv4 Dynamic Home Agent (HA) Assignment".
- [28] Void.
- [29] IETF RFC 4861: "Neighbor Discovery for IP version 6 (IPv6)".
- [30] IETF RFC 4862: "IPv6 Stateless Address Autoconfiguration".
- [31] IETF RFC 5216: "The EAP-TLS Authentication Protocol".
- [32] IETF RFC 5246: "The Transport Layer Security (TLS) Protocol Version 1.2".
- [33] IETF RFC 5281 (August 2008): "Extensible Authentication Protocol Tunnelled Transport Layer Security Authenticated Protocol Version 0 (EAP-TLSv0)".
- [34] IETF draft-ietf-mip6-hiopt-17.txt: "DHCP Option for Home Information Discovery in MIPv6".

- [35] ETSI ETS 300 406: "Methods for Testing and Specification (MTS); Protocol and profile conformance testing specifications; Standardization methodology".
- [36] ETSI ES 201 873-1: "Methods for Testing and Specification (MTS); The Testing and Test Control Notation version 3; Part 1: TTCN-3 Core Language".
- [37] Void.
- [38] ETSI ES 201 873-6: "Methods for Testing and Specification (MTS); The Testing and Test Control Notation version 3; Part 6: TTCN-3 Control Interface (TCI)".
- [39] ISO/IEC 9646-1 (1994): "Information technology - Open Systems Interconnection - Conformance testing methodology and framework - Part 1: General concepts". (See also ITU-T Recommendation X.290 (1991)).
- [40] ISO/IEC 9646-2 (1994): "Information technology - Open Systems Interconnection - Conformance testing methodology and framework - Part 2: Abstract Test Suite specification". (See also ITU-T Recommendation X.291 (1991)).
- [41] ISO/IEC 9646-6 (1994): "Information technology - Open Systems Interconnection - Conformance testing methodology and framework - Part 6: Protocol profile test specification".
- [42] ISO/IEC 9646-7 (1995): "Information technology - Open Systems Interconnection - Conformance testing methodology and framework - Part 7: Implementation Conformance Statement".
- [43] IETF RFC 761: "DoD standard Transmission Control Protocol".
- [44] IETF RFC 3486: "Compressing the Session Initiation Protocol (SIP)".
- [45] IETF RFC 3957: "Authentication, Authorization, and Accounting (AAA) Registration Keys for Mobile IPv4".
- [46] Void.
- [47] Void.
- [48] Void.
- [49] Void.
- [50] IETF RFC 4286: "Multicast Router Discovery".
- [51] IETF RFC 4721: "Mobile IPv4 Challenge/Response Extensions (Revised)".
- [52] IETF RFC 4857: "Mobile IPv4 Regional Registration".
- [53] IETF RFC 4988: "Mobile IPv4 Fast Handovers".
- [54] IETF RFC 2782: "A DNS RR for specifying the location of services (DNS SRV)".
- [55] IETF RFC 2616: "Hypertext Transfer Protocol - HTTP/1.1".

NOTE: Available at: <http://www.ietf.org/rfc/rfc2616.txt>.

- [56] Void.
- [57] Void.
- [58] Void.

[59] Open Mobile Alliance WAP-235-PushOTA-20010425-a: "Push OTA Protocol".

NOTE: Available at: <http://www.openmobilealliance.org>.

[60] Open Mobile Alliance WAP-251-PushMessage-20010322-a: "Push Message".

NOTE: Available at: <http://www.openmobilealliance.org>.

2.2 Informative references

The following referenced documents are not essential to the use of the present document but they assist the user with regard to a particular subject area. For non-specific references, the latest version of the referenced document (including any amendments) applies.

- [i.1] ETSI TS 102 624-1: "Broadband Radio Access Networks (BRAN); HiperMAN; Conformance Testing for the Network layer of HiperMAN/WiMAX terminal devices; Part 1: Protocol Implementation Conformance Statement (PICS) proforma".
- [i.2] ISO/IEC 9646 (all parts): "Information technology - Open Systems Interconnection - Conformance testing methodology and framework".

3 Definitions and abbreviations

3.1 Definitions

For the purposes of the present document, the terms and definitions given in ISO/IEC 9646-7 [42], TS 102 545-3 [5], IEEE 802.16e-2005 [6] and IEEE 802.16g-2007 [7], [1] and [2] apply.

3.2 Abbreviations

For the purposes of the present document, the abbreviations given in TS 102 545-3 [5], ISO/IEC 9646-1 [39], ISO/IEC 9646-6 [41], ISO/IEC 9646-7 [42], IEEE 802.16e-2005 [6], IEEE 802.16g-2007 [7], [1], [2] and the following apply:

AKA	Authentication and Key Agreement
ATS	Abstract Test Suite
AVP	Attribute Value Pair
BS	Base Station
CID	Connection IDentifier
CMAC	Cipher-based MAC
CS	Convergence Sublayer
DHCP	Dynamic Host Configuration Protocol
DIUC	Downlink Interval Usage Code
DLC	Data Link Control
EAP	Extensible Authentication Protocol
ICMP	Internet Control Message Protocol
IGMP	Internet Group Membership Protocol
IP	Internet Protocol
IUT	Implementation Under Test
MIP	Mobile IP
NAP	Network Access Provider
NCT	Network Conformance Tests
NSP	Network Service Provider
NWE	Network Entry
OFDM	Orthogonal Frequency Division Multiplexing
OSI	Open Systems Interconnection
PA	Platform Adapter
PCO	Point of Control and Observation
PCT	Protocol Conformance Tests
PCTR	Protocol Conformance Test Report
PHY	Physical layer
PIXIT	Partial Protocol Implementation Extra Information for Testing
REQ	REQuest
RSP	ReSPonse
SA	SUT Adapter
SS	Subscriber Station

SUT	System Under Test
TA	Test Adapter
TC	Test Case
TLS	Transport Layer Security
TLV	Type, Length, Value
TP	Test Purposes
TTCN	Test and Test Control Notation
TTLS	Tunnelled TLS
UIUC	Uplink Interval Usage Code

4 Abstract Test Method (ATM)

This clause describes the ATM used to test the Network layer of the HiperMAN/WiMAX terminal devices.

NOTE: In the present document the normative terms SUT Adapter (SA), Platform Adapter (PA) and CODECS as defined by TTCN-3 standards [36] are used. The non-normative term Test Adaptor (TA) is also used for backward compatibility with TS 102 545-3 [5] and embodies SA, PA and CODECS concepts.

4.1 Test architecture

4.1.1 Points of Observation and Control

Testing BRAN HiperMAN/WiMAX terminal devices for conformance across WiMAX networks involves the participation of many procedures and protocols. In order to delimit the scope of NCT, the identification of Points of Observation and Control (i.e. PCO as defined in ISO/IEC 9646-1 [39]) become of utmost importance.

After an exhaustive analysis of the NWG base standards WiMAX Forum Network Architecture; Stage 2 [1], WiMAX Forum Network Architecture; Stage 3 [2] and TS 102 624-2 [1], the PCO for "Conformance Testing for the Network layer of the HiperMAN/WiMAX terminal devices" are identified.

PCO are depicted in figure 1 on an OSI model representation of the WiMAX terminal device in all the scenarios considered in the present document.

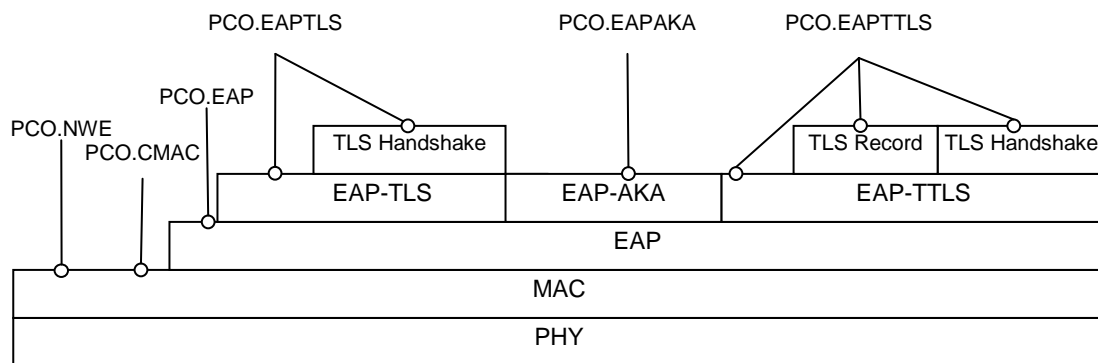

PCO for Network Discovery and Selection Security Test Groups

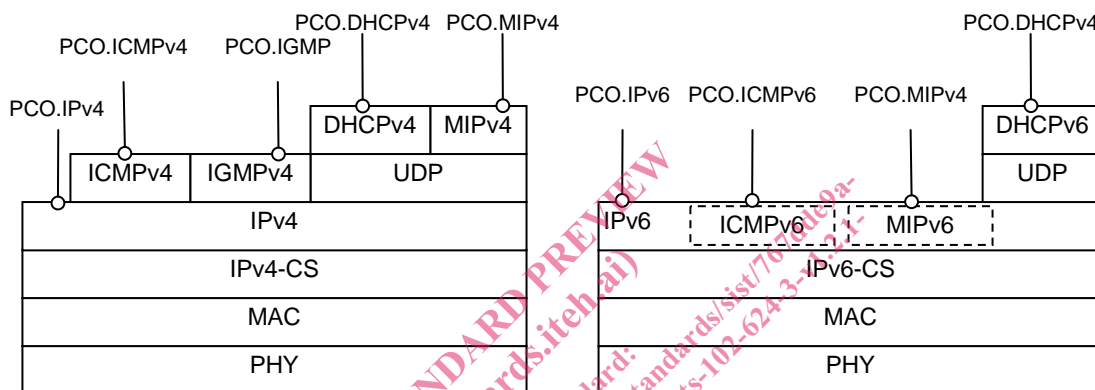

PCO for IP4, CMIP4 and DHCP4 Test Groups

PCO for IP6 and CMIP6 Test Groups

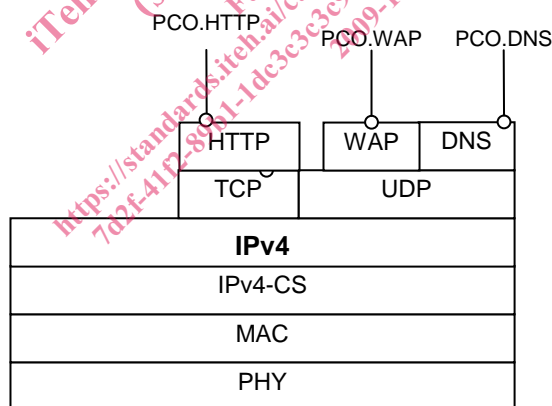

PCO for OTA Test Groups

Figure 1: Points of Observation and Control

Each PCO identified above is specified in IETF standards (with the exception of PCO.NWE and PCO.CMAC).

Since protocols usually have extensions and options, several standards may be needed to specify one single protocol in its completeness. However, the scope of the present document is limited to the IETF standards applicable in NWG base standards. The list of standards which specifies the protocols involved in the network functionalities to be tested in accordance with TS 102 624-2 [4] is given in table 1.

Table 1: IEEE and IETF standards for NCT PCOs

PCO	Standards
PCO.NWE	IEEE P802.16g/ D9, April 2007 [7]
PCO.CMAC	IEEE 802.16e-2005 [6]
PCO.MIPv4	RFC 3344 [19], RFC 3543 [20], RFC 3846 [23] and RFC 4433 [27]
PCO.MIPv6	RFC 3775 [22], RFC 4283 [25] and RFC 4285 [26]
PCO.IPv6	RFC 2460 [16]
PCO.DHCPv4	RFC 2131 [14] and RFC 2132 [15]
PCO.DHCPv6	RFC 3315 [18] and IETF draft draft_ietf_mip6_hiop17.txt [34].
PCO.ICMPv4	RFC 792 [10] and RFC 1256 [13].
PCO.ICMPv6	RFC 4861 [29] and RFC 4862 [30]
PCO.IGMP	RFC 1112 [12]
PCO.EAP	RFC 3748 [21]
PCO.EAPTLS	RFC 5246 [32] and RFC 5216 [31]
PCO.EAPTTLS	RFC 5281 [33]
PCO.AKA	RFC 4187 [24]
PCO.HTTP	RFC 2616 [55]
PCO.WAP	?? OMA DM Protocol
PCO.DNS	RFC 2782 [54]

New PCO may be identified as new network functionalities become target of NCT testing in future releases of TS 102 624-2 [4]. Likewise, new IETF standards may become within the scope of NCT testing.

The present document also deals with the processing of protocols, messages and fields which currently remains outside the scope of NCT testing. See details in clauses 6.1.3 and 6.1.4.

4.1.2 Architectural Requirements

Based on the PCO identification, and considering compatibility with existing standards a desirable system property, the following list of architectural requirements is proposed. These requirements are to be accomplished in the definition of the Abstract Test Method.

4.1.2.1 Reuse of DLC-TTCN

Table 2: TTCN-3 Test Suite Requirements

ID	Description
REQ-1-ATS	NCT TTCN-3 test suite shall use the existing DLC-TTCN (TS 102 545-3 [5]) in order to operate the DLC layer when required by NCT test cases (e.g. test preambles).
REQ-2-ATS	NCT TTCN-3 test suite shall rely on TA (SA part) for the implementation of the WiMAX PHY layer (according to IEEE 802.16e-2005 [6]).
REQ-3-ATS	NCT TTCN-3 test suite shall rely on TA (PA part) for the implementation of the EAP protocol and the upper security methods. Initial implementation will cover mandatory features and optional features may be developed provided that IUT support is available.

Table 3: Test Adaptor Requirements

ID	Description
REQ-1-TA	TA shall use existing DLC-TTCN SA keeping the same TRI interface to serve the DLC-TTCN ports: TA, Phy, MacMsg, MacBcMsg and MacPdu.
REQ-2-TA	TA shall use an upgraded version of the DLC-TTCN Platform Adapter to deal with the EAP protocol and the upper security methods. See REQ-4-TA for upgrade scope.
REQ-3-TA	TA shall use the DLC-TTCN CODECS subsystem for DLC messages in order to code the messages transported by the DLC-TTCN3 ports: TA, Phy, MacMsg, MacBcMsg and MacPdu.