

**Electromagnetic compatibility
and Radio spectrum Matters (ERM);
ElectroMagnetic Compatibility (EMC)
standard for radio equipment and services;
Part 12: Specific conditions for Very Small Aperture
Terminal, Satellite Interactive Earth Stations operated
in the frequency ranges between 4 GHz and 30 GHz
in the Fixed Satellite Service (FSS)**

iTeh STANDARD PREVIEW
(standards.iteh.ai)
Full standard:
<https://standards.iteh.ai/catalog/standards/sist/286f2e7f-02b4-445c-821d-98e43b8ac492/etsi-en-301-489-12-v2.2.2-2008-09>



Reference

REN/ERM-EMC-265-12

Keywordsearth station, EMC, FSS, radio, regulation,
satellite, SNG, testing, VSAT**ETSI**650 Route des Lucioles
F-06921 Sophia Antipolis Cedex - FRANCE

Tel.: +33 4 92 94 42 00 Fax: +33 4 93 65 47 16

Siret N° 348 623 562 00017 - NAF 742 C
Association à but non lucratif enregistrée à la
Sous-Préfecture de Grasse (06) N° 7803/88

Important notice

Individual copies of the present document can be downloaded from:

<http://www.etsi.org>

The present document may be made available in more than one electronic version or in print. In any case of existing or perceived difference in contents between such versions, the reference version is the Portable Document Format (PDF). In case of dispute, the reference shall be the printing on ETSI printers of the PDF version kept on a specific network drive within ETSI Secretariat.

Users of the present document should be aware that the document may be subject to revision or change of status. Information on the current status of this and other ETSI documents is available at

<http://portal.etsi.org/tb/status/status.asp>

If you find errors in the present document, please send your comment to one of the following services:

http://portal.etsi.org/chaicor/ETSI_support.asp

Copyright Notification

No part may be reproduced except as authorized by written permission.
The copyright and the foregoing restriction extend to reproduction in all media.

© European Telecommunications Standards Institute 2008.
All rights reserved.

DECT™, PLUGTESTS™, UMTS™, TIPHON™, the TIPHON logo and the ETSI logo are Trade Marks of ETSI registered for the benefit of its Members.

3GPP™ is a Trade Mark of ETSI registered for the benefit of its Members and of the 3GPP Organizational Partners.

Contents

Intellectual Property Rights	5
Foreword.....	5
1 Scope	6
2 References	6
2.1 Normative references	6
2.2 Informative references.....	7
3 Definitions and abbreviations.....	7
3.1 Definitions.....	7
3.2 Abbreviations	7
4 Test conditions	8
4.1 General	8
4.2 Arrangements for test signals	8
4.2.1 Arrangements for test signals at the input of transmitters.....	8
4.2.2 Arrangements for test signals at the output of transmitters.....	8
4.2.3 Arrangements for test signals at the input of receivers	9
4.2.4 Arrangements for test signals at the output of receivers	9
4.2.5 Arrangements for testing transmitter and receiver together (as a system).....	9
4.3 Exclusion bands.....	9
4.4 Narrow band responses of receivers	9
5 Performance assessment.....	9
5.1 General	9
5.2 Equipment configuration(s).....	9
5.3 Equipment classification	10
6 Performance criteria	11
6.1 Performance criteria (C) for Continuous phenomena applied to the EUT	11
6.2 Performance criteria (TA) for Transient phenomena applied to a grade A EUT.....	11
6.3 Performance criteria (TB) for Transient phenomena applied to a grade B EUT	12
7 Applicability overview	12
7.1 Emission.....	12
7.1.1 General.....	12
7.1.2 Special conditions	12
7.2 Immunity	12
7.2.1 General.....	12
7.2.2 Special conditions.....	13
Annex A (normative): Definitions of Satellite Earth Stations (ES) within the scope of the present document.....	14
A.1 Transmit only and Transmit and receive Ku band VSATs	14
A.2 Receive-only Ku band VSATs.....	14
A.3 Transmit only and Transmit and receive C band VSATs.....	15
A.4 Receive-only C band VSATs	15
A.5 Satellite News Gathering (SNG) Ku band Transportable Earth Stations (TESs).....	16
A.6 Satellite Interactive Terminals (SITs)	17
A.7 Satellite User Terminals (SUTs) transmitting in the frequency range 29,5 GHz to 30,0 GHz	17
A.8 Satellite User Terminals (SUTs) transmitting in the frequency range 27,5 GHz to 29,5 GHz	18
A.9 Satellite Earth Station on Trains (EST) transmitting in the frequency range 14,0 GHz to 14,5 GHz....	19

Annex B (informative):	Bibliography.....	20
Annex C (informative):	The EN title in the official languages	21
History		23

iTeh STANDARD PREVIEW
(standards.iteh.ai)

Full standard:
<https://standards.iteh.ai/catalog/standards/sist/286f2e7f-02b4-445c-821d-98e43b8ac492/etsi-en-301-489-12-v2.2.2-2008-09>

Intellectual Property Rights

IPRs essential or potentially essential to the present document may have been declared to ETSI. The information pertaining to these essential IPRs, if any, is publicly available for **ETSI members and non-members**, and can be found in ETSI SR 000 314: "*Intellectual Property Rights (IPRs); Essential, or potentially Essential, IPRs notified to ETSI in respect of ETSI standards*", which is available from the ETSI Secretariat. Latest updates are available on the ETSI Web server (<http://webapp.etsi.org/IPR/home.asp>).

Pursuant to the ETSI IPR Policy, no investigation, including IPR searches, has been carried out by ETSI. No guarantee can be given as to the existence of other IPRs not referenced in ETSI SR 000 314 (or the updates on the ETSI Web server) which are, or may be, or may become, essential to the present document.

Foreword

This Harmonized European Standard (Telecommunications series) has been produced by ETSI Technical Committee Electromagnetic compatibility and Radio spectrum Matters (ERM), and is now submitted for the Vote phase of the ETSI standards Two-step Approval Procedure.

The present document has been produced by ETSI in response to a mandate from the European Commission issued under Council Directive 98/34/EC [i.2] (as amended) laying down a procedure for the provision of information in the field of technical standards and regulations.

The present document, together with EN 301 489-1 [1], is intended to become a Harmonized Standard, the reference of which will be published in the Official Journal of the European Communities referencing the Directive 1999/5/EC [i.1] of the European Parliament and of the Council of 9 March 1999 on radio equipment and telecommunications terminal equipment and the mutual recognition of their conformity ("the R&TTE Directive").

The present document is part 12 of a multi-part deliverable. Full details of the entire series can be found in part 1 [1].

Proposed national transposition dates	
Date of latest announcement of this EN (doa):	3 months after ETSI publication
Date of latest publication of new National Standard or endorsement of this EN (dop/e):	6 months after doa
Date of withdrawal of any conflicting National Standard (dow):	18 months after doa

1 Scope

The present document, together with EN 301 489-1 [1], covers the assessment of Earth Stations (ES) operated in the frequency ranges between 4 GHz and 30 GHz in the Fixed Satellite Service (FSS) and associated ancillary equipment in respect of Electromagnetic Compatibility (EMC).

Technical specifications related to the antenna port and emissions from the enclosure port of the Earth Stations (ES) are not included in the present document. Such technical specifications are found in the relevant product standards for the effective use of the radio spectrum.

The present document specifies the applicable test conditions, performance assessment and the performance criteria for the ESs, and associated ancillary equipment.

Definitions of the type of Earth Stations (ES) operated in the frequency ranges between 4 GHz and 30 GHz in the Fixed Satellite Service (FSS) covered by the present document are given in annex A.

In case of differences (for instance concerning special conditions, definitions, abbreviations) between the present document and EN 301 489-1 [1], the provisions of the present document take precedence.

The environmental classification and the emission and immunity requirements used in the present document are as stated in EN 301 489-1 [1], except for any special conditions included in the present document. The applicable environments referred to in EN 301 489-1 [1] where equipment covered by the scope of the present document may be used, shall be declared by the manufacturer.

2 References

References are either specific (identified by date of publication and/or edition number or version number) or non-specific.

- For a specific reference, subsequent revisions do not apply.
- Non-specific reference may be made only to a complete document or a part thereof and only in the following cases:
 - if it is accepted that it will be possible to use all future changes of the referenced document for the purposes of the referring document;
 - for informative references.

Referenced documents which are not found to be publicly available in the expected location might be found at <http://docbox.etsi.org/Reference>.

For online referenced documents, information sufficient to identify and locate the source shall be provided. Preferably, the primary source of the referenced document should be cited, in order to ensure traceability. Furthermore, the reference should, as far as possible, remain valid for the expected life of the document. The reference shall include the method of access to the referenced document and the full network address, with the same punctuation and use of upper case and lower case letters.

NOTE: While any hyperlinks included in this clause were valid at the time of publication ETSI cannot guarantee their long term validity.

2.1 Normative references

The following referenced documents are indispensable for the application of the present document. For dated references, only the edition cited applies. For non-specific references, the latest edition of the referenced document (including any amendments) applies.

- [1] ETSI EN 301 489-1 (V.1.8.1): "Electromagnetic compatibility and Radio spectrum Matters (ERM); ElectroMagnetic Compatibility (EMC) standard for radio equipment and services; Part 1: Common technical requirements".

2.2 Informative references

The following referenced documents are not essential to the use of the present document but they assist the user with regard to a particular subject area. For non-specific references, the latest version of the referenced document (including any amendments) applies.

- [i.1] Directive 1999/5/EC of the European Parliament and of the Council of 9 March 1999 on radio equipment and telecommunications terminal equipment and the mutual recognition of their conformity (R&TTE Directive).
- [i.2] Directive 98/34/EC of the European Parliament and of the Council of 22 June 1998 laying down a procedure for the provision of information in the field of technical standards and regulations.
- [i.3] ERC/DEC(00)08: "ERC Decision of 19 October 2000 on the use of the band 10.7 - 12.5 GHz by the fixed service and Earth stations of the broadcasting-satellite and fixed-satellite Service (space-to-Earth)".
- [i.4] ERC/DEC(00)07: "ERC Decision of 19 October 2000 on the shared use of the band 17.7 - 19.7 GHz by the fixed service and Earth stations of the fixed-satellite service (space-to-Earth)".

3 Definitions and abbreviations

3.1 Definitions

For the purposes of the present document, the terms and definitions given in EN 301 489-1 [1] and the following apply:

carrier-on state: transmit ES is in this state when it is authorized to transmit, and when it transmits a signal, either authorized by a Centralized Control and Monitoring Function (CCMF) or a Network Control Facility (NCF) when designed for unattended operation or by local control when designed for attended operation

carrier-off state: transmit ES is in this state when it is authorized to transmit, and when it does not transmit any signal, either authorized by a CCMF or a NCF when designed for unattended operation or by local control when designed for attended operation

NOTE: The existence of a carrier-off state depends on the system of transmission used. For ES designed for continuous transmission mode there may be no carrier-off state.

transmission disabled state: transmit ES is in this state when it is not authorized to transmit either by a CCMF or a NCF respectively when designed for unattended operation or by local control when designed for attended operation

3.2 Abbreviations

For the purposes of the present document, the following abbreviations apply:

AMSS	Aeronautical Mobile Satellite Service
BSS	Broadcast Satellite Service
CCMF	Centralized Control and Monitoring Functions
EIRP	Equivalent Isotropically Radiated Power
EMC	ElectroMagnetic Compatibility
EME	Externally Mounted Equipment
ES	Earth Station
EST	Earth Station on Trains
EUT	Equipment Under Test
FS	Fixed Services
FSS	Fixed Satellite Service
IME	Internally Mounted Equipment
LMSS	Land Mobile Satellite Service
LNB	Low Noise Block converter
MMSS	Marine Mobile Satellite Service

MSS	Mobile Satellite Service
NCF	Network Control Facility
QTMA	Quality of Transmission Measurement Apparatus
RF	Radio Frequency
SIT	Satellite Interactive Terminals
SNG	Satellite News Gathering
SUT	Satellite User Terminals
TES	Transportable Earth Station
VSAT	Very Small Aperture Terminal

4 Test conditions

For the purposes of the present document, the test conditions of EN 301 489-1 [1], clause 4 shall apply as appropriate. Further product type related test conditions for Earth Stations are specified in the present document.

4.1 General

For Earth Stations with or without ancillary equipment, and/or various terrestrial ports, the number of test configurations shall be determined. The assessment shall include sufficient representative configurations of the ES to adequately exercise the equipment. These configurations shall be recorded in the test report.

In the following clauses, the Equipment Under Test (EUT) is an ES with the selected configuration of ancillary equipment.

4.2 Arrangements for test signals

The provisions of EN 301 489-1 [1], clause 4.2 shall apply with the following modifications.

In order to measure the unwanted emissions and electromagnetic immunity under operational conditions, the following arrangements shall be provided by the manufacturer:

- a) a special test equipment to put the ES terminal in its normal operating mode, and providing the ES with a receive signal to emulate the operational conditions of reception. This equipment shall control the EUT, when it is capable of transmission, so that it switches between the transmission disabled, carrier-on and carrier-off states;
- b) the specific Quality of Transmission Measurement Apparatus (QTMA).

For the measurement of the quality of transmission a communications link shall be established and the wanted input signal shall be applied to the Radio Frequency (RF) input of the receiver via the antenna.

The special test equipment, the QTMA and the source of the wanted input signal shall be located outside the test environment. Adequate measures shall be taken to protect them from the effects of all the radiated fields within the test environment.

4.2.1 Arrangements for test signals at the input of transmitters

The provisions of EN 301 489-1 [1], clause 4.2.1 shall apply.

4.2.2 Arrangements for test signals at the output of transmitters

The provisions of EN 301 489-1 [1], clause 4.2.2 shall apply.

4.2.3 Arrangements for test signals at the input of receivers

The provisions of EN 301 489-1 [1], clause 4.2.3 shall apply with the following modification.

For tests on the receiver, the level of the signal received from the test transmitter shall be as close as possible to the normal operation level of the EUT receiver.

4.2.4 Arrangements for test signals at the output of receivers

The provisions of EN 301 489-1 [1], clause 4.2.4 shall apply.

4.2.5 Arrangements for testing transmitter and receiver together (as a system)

The provisions of EN 301 489-1 [1], clause 4.2.5 shall apply.

4.3 Exclusion bands

There are no exclusion bands for ESs within in the scope of the present document.

4.4 Narrow band responses of receivers

Narrow band responses are not allowed for ESs within in the scope of the present document.

5 Performance assessment

5.1 General

The provision of EN 301 489-1 [1], clause 5.1 shall apply.

In addition the manufacturer shall provide the following information to be recorded in the test report:

- the dedicated grade (A or B) for the ES in accordance with the information contained in the instructions accompanying the ES (see clause 5.3);
- the ranges of the operational parameters, e.g. the power delivered to the antenna, the frequency ranges;
- the minimum quality of transmission, and the method to be used to assess it.

This information shall be in accordance with the documentation accompanying the equipment.

5.2 Equipment configuration(s)

For radiation measurements in carrier-on state, the ES shall be put in a continuous transmit mode or to the maximum burst rate where applicable. The ES shall be operated at the highest normal operating Equivalent Isotropically Radiated Power (EIRP) or, if that is the maximum attainable, then 3 dB below such maximum.

A suggested test configuration is shown in figure 1.

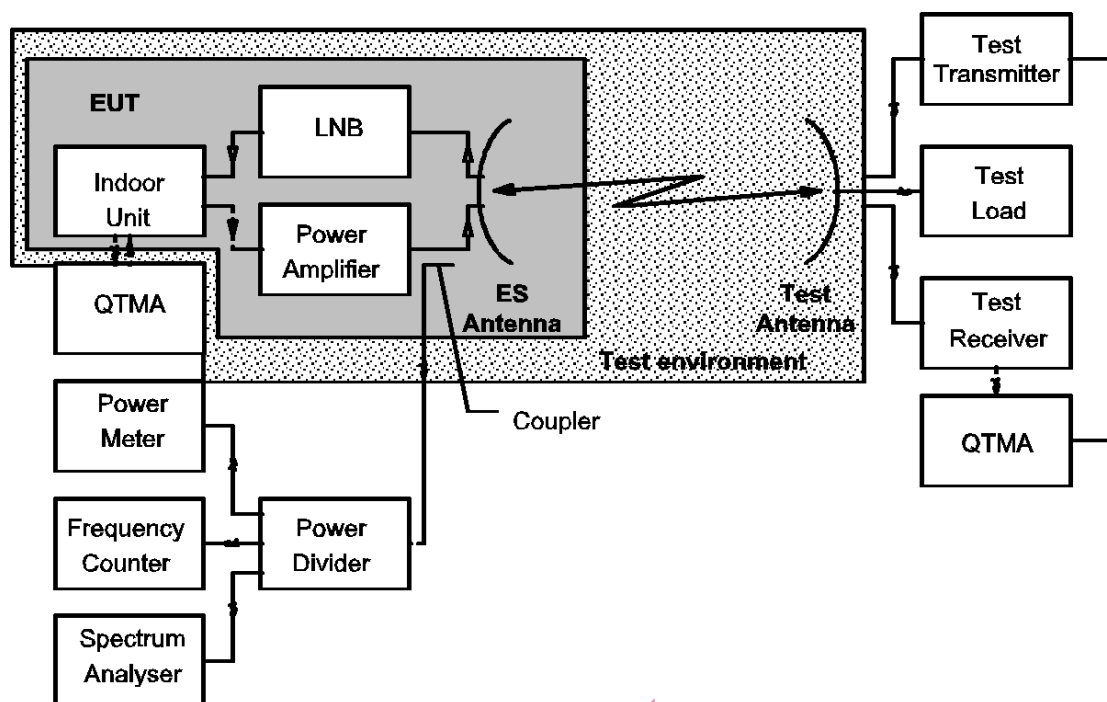

Figure 1: Suggested test configuration

For the tests, the ES antenna reflector and the test antenna may be removed at their flanges and be replaced by one direct wave guide connection.

The following test equipment shall be the means whereby the correct operation of the EUT is verified:

- a) the power meter measures the output power and is used to confirm the transmission disabled, carrier-on and carrier-off states and output level consistency;
- b) the frequency counter measures the centre frequency of the radiated carrier in the absence of modulation;
- c) the spectrum analyser measures the bandwidth of the transmission;
- d) the test receiver is used to demodulate the transmitted signal;
- e) the two QTMA are used in conjunction with each other to assess the quality of transmission;
- f) the test transmitter is used to control the switching between transmission disabled, carrier-on and carrier-off states by transmitting the control and monitoring signals.

5.3 Equipment classification

The provisions of EN 301 489-1 [1], clause 5.5 set out for base stations shall apply with the following addition.

The equipment are classified into the two grades of service:

- grade A of ES for which short interruptions of transmission are accepted during immunity testing with EMC transient phenomena;
- grade B of ES for which no short interruption of transmission is accepted during immunity testing with EMC transient phenomena.

The applicable grade A or B shall be declared by the manufacturer, it shall be in accordance with the information contained in the instructions accompanying the ES, and shall be recorded in the test report.