

ETSI TS 125 213 V7.4.0 (2008-01)

Technical Specification

Universal Mobile Telecommunications System (UMTS); Spreading and modulation (FDD) (3GPP TS 25.213 version 7.4.0 Release 7)



iTeh STANDARD PREVIEW
(standards.iteh.ai)

Full standard:
<https://standards.iteh.ai/catalog/standards/sist/e86caa38-8e70-46bd-b832-6d7835dbaf97/etsi-ts-125-213-v7.4.0-2008-01>



Reference

RTS/TSGR-0125213v740

Keywords

UMTS**ETSI**

650 Route des Lucioles
F-06921 Sophia Antipolis Cedex - FRANCE

Tel.: +33 4 92 94 42 00 Fax: +33 4 93 65 47 16

Siret N° 348 623 562 00017 - NAF 742 C
Association à but non lucratif enregistrée à la
Sous-Préfecture de Grasse (06) N° 7803/88

Important notice

Individual copies of the present document can be downloaded from:

<http://www.etsi.org>

The present document may be made available in more than one electronic version or in print. In any case of existing or perceived difference in contents between such versions, the reference version is the Portable Document Format (PDF). In case of dispute, the reference shall be the printing on ETSI printers of the PDF version kept on a specific network drive within ETSI Secretariat.

Users of the present document should be aware that the document may be subject to revision or change of status. Information on the current status of this and other ETSI documents is available at

<http://portal.etsi.org/tb/status/status.asp>

If you find errors in the present document, please send your comment to one of the following services:

http://portal.etsi.org/chaicor/ETSI_support.asp

Copyright Notification

No part may be reproduced except as authorized by written permission.
The copyright and the foregoing restriction extend to reproduction in all media.

© European Telecommunications Standards Institute 2008.
All rights reserved.

DECT™, PLUGTESTS™, UMTS™, TIPHON™, the TIPHON logo and the ETSI logo are Trade Marks of ETSI registered for the benefit of its Members.

3GPP™ is a Trade Mark of ETSI registered for the benefit of its Members and of the 3GPP Organizational Partners.

Intellectual Property Rights

IPRs essential or potentially essential to the present document may have been declared to ETSI. The information pertaining to these essential IPRs, if any, is publicly available for **ETSI members and non-members**, and can be found in ETSI SR 000 314: "*Intellectual Property Rights (IPRs); Essential, or potentially Essential, IPRs notified to ETSI in respect of ETSI standards*", which is available from the ETSI Secretariat. Latest updates are available on the ETSI Web server (<http://webapp.etsi.org/IPR/home.asp>).

Pursuant to the ETSI IPR Policy, no investigation, including IPR searches, has been carried out by ETSI. No guarantee can be given as to the existence of other IPRs not referenced in ETSI SR 000 314 (or the updates on the ETSI Web server) which are, or may be, or may become, essential to the present document.

Foreword

This Technical Specification (TS) has been produced by ETSI 3rd Generation Partnership Project (3GPP).

The present document may refer to technical specifications or reports using their 3GPP identities, UMTS identities or GSM identities. These should be interpreted as being references to the corresponding ETSI deliverables.

The cross reference between GSM, UMTS, 3GPP and ETSI identities can be found under <http://webapp.etsi.org/key/queryform.asp>.

ITeH STANDARD PREVIEW
(standards.iteh.ai)
Full standard:
<https://standards.iteh.ai/catalog/standards/sist/e86c2338-8e70-46bd-b832-6d7835dbaf97/etsi-ts-125-213-v7.4.0>
2008-01

Contents

Intellectual Property Rights	2
Foreword.....	2
Foreword.....	5
1 Scope	6
2 References	6
3 Symbols and abbreviations.....	6
3.1 Symbols.....	6
3.2 Abbreviations	6
4 Uplink spreading and modulation	7
4.1 Overview	7
4.2 Spreading.....	7
4.2.1 Dedicated physical channels	7
4.2.1.1 DPCCH/DPDCH	9
4.2.1.2 HS-DPCCH.....	10
4.2.1.3 E-DPDCH/E-DPCCH	11
4.2.2 PRACH.....	17
4.2.2.1 PRACH preamble part	17
4.2.2.2 PRACH message part.....	17
4.2.3 Void.....	18
4.3 Code generation and allocation	18
4.3.1 Channelisation codes	18
4.3.1.1 Code definition.....	18
4.3.1.2 Code allocation for dedicated physical channels.....	19
4.3.1.2.1 Code allocation for DPCCH/DPDCH	19
4.3.1.2.2 Code allocation for HS-DPCCH.....	19
4.3.1.2.3 Code allocation for E-DPCCH/E-DPDCH	19
4.3.1.3 Code allocation for PRACH message part	20
4.3.1.4 Void.....	20
4.3.1.5 Void.....	20
4.3.2 Scrambling codes	20
4.3.2.1 General	20
4.3.2.2 Long scrambling sequence	20
4.3.2.3 Short scrambling sequence.....	21
4.3.2.4 Dedicated physical channels scrambling code	22
4.3.2.5 PRACH message part scrambling code.....	22
4.3.2.6 Void.....	23
4.3.2.7 Void.....	23
4.3.3 PRACH preamble codes	23
4.3.3.1 Preamble code construction	23
4.3.3.2 Preamble scrambling code	23
4.3.3.3 Preamble signature	23
4.3.4 Void	24
4.4 Modulation	24
4.4.1 Modulating chip rate	24
4.4.2 Modulation.....	24
5 Downlink spreading and modulation	25
5.1 Spreading.....	25
5.1.1 Modulation mapper.....	25
5.1.1.1 QPSK	25
5.1.1.2 16QAM	26
5.1.1.3 64QAM	26
5.1.2 Channelisation	27
5.1.3 IQ combining	27

5.1.4 Scrambling27

5.1.5 Channel combining27

5.2 Code generation and allocation28

5.2.1 Channelisation codes28

5.2.2 Scrambling code29

5.2.3 Synchronisation codes30

5.2.3.1 Code generation30

5.2.3.2 Code allocation of SSC31

5.3 Modulation33

5.3.1 Modulating chip rate33

5.3.2 Modulation33

Annex A (informative): Generalised Hierarchical Golay Sequences.....34

A.1 Alternative generation34

Annex B (informative): Change history35

History37

iTeh STANDARD PREVIEW
 (standards.iteh.ai)
 Full standard:
<https://standards.iteh.ai/catalog/standards/sist/e86caa38-8e70-46bd-b832-6d7835dbaf97/etsi-ts-125-213-v7.4.0-2008-01>

Foreword

This Technical Specification (TS) has been produced by the 3rd Generation Partnership Project (3GPP).

The contents of the present document are subject to continuing work within the TSG and may change following formal TSG approval. Should the TSG modify the contents of the present document, it will be re-released by the TSG with an identifying change of release date and an increase in version number as follows:

Version x.y.z

where:

- x the first digit:
 - 1 presented to TSG for information;
 - 2 presented to TSG for approval;
 - 3 or greater indicates TSG approved document under change control.
- y the second digit is incremented for all changes of substance, i.e. technical enhancements, corrections, updates, etc.
- z the third digit is incremented when editorial only changes have been incorporated in the document.

iTeh STANDARD PREVIEW
(standards.iteh.ai)
Full standard:
<https://standards.iteh.ai/catalog/standards/sist/etsi-125-213-v7.4.0-2008-01>
8e70-46bd-b832-6d7835dbaf97/etsi-ts-125-213-v7.4.0-

1 Scope

The present document describes spreading and modulation for UTRA Physical Layer FDD mode.

2 References

The following documents contain provisions which, through reference in this text, constitute provisions of the present document.

- References are either specific (identified by date of publication, edition number, version number, etc.) or non-specific.
- For a specific reference, subsequent revisions do not apply.
- For a non-specific reference, the latest version applies. In the case of a reference to a 3GPP document (including a GSM document), a non-specific reference implicitly refers to the latest version of that document *in the same Release as the present document*.

- [1] 3GPP TS 25.201: "Physical layer - general description".
- [2] 3GPP TS 25.211: "Physical channels and mapping of transport channels onto physical channels (FDD)."
- [3] 3GPP TS 25.101: "UE Radio transmission and Reception (FDD)".
- [4] 3GPP TS 25.104: "UTRA (BS) FDD; Radio transmission and Reception".
- [5] 3GPP TS 25.308: "UTRA High Speed Downlink Packet Access (HSDPA); Overall description".
- [6] 3GPP TS 25.214: "Physical layer procedures (FDD)".
- [7] 3GPP TS 25.212: "Multiplexing and channel coding (FDD)".
-

3 Symbols and abbreviations

3.1 Symbols

For the purposes of the present document, the following symbols apply:

$C_{ch,SF,n}$:	n :th channelisation code with spreading factor SF
$C_{pre,n,s}$:	PRACH preamble code for n :th preamble scrambling code and signature s
$C_{sig,s}$:	PRACH signature code for signature s
$S_{dpch,n}$:	n :th DPCCH/DPDCH uplink scrambling code
$S_{r-pre,n}$:	n :th PRACH preamble scrambling code
$S_{r-msg,n}$:	n :th PRACH message scrambling code
$S_{dl,n}$:	DL scrambling code
C_{psc} :	PSC code
$C_{ssc,n}$:	n :th SSC code

3.2 Abbreviations

For the purposes of the present document, the following abbreviations apply:

16QAM	16 Quadrature Amplitude Modulation
64QAM	64 Quadrature Amplitude Modulation

AICH	Acquisition Indicator Channel
BCH	Broadcast Control Channel
CCPCH	Common Control Physical Channel
CPICH	Common Pilot Channel
DCH	Dedicated Channel
DPCH	Dedicated Physical Channel
DPCCH	Dedicated Physical Control Channel
DPDCH	Dedicated Physical Data Channel
E-AGCH	E-DCH Absolute Grant Channel
E-DPCCH	E-DCH Dedicated Physical Control Channel
E-DPDCH	E-DCH Dedicated Physical Data Channel
E-HICH	E-DCH Hybrid ARQ Indicator Channel
E-RGCH	E-DCH Relative Grant Channel
FDD	Frequency Division Duplex
F-DPCH	Fractional Dedicated Physical Channel
HS-DPCCH	Dedicated Physical Control Channel (uplink) for HS-DSCH
HS-DSCH	High Speed Downlink Shared Channel
HS-PDSCH	High Speed Physical Downlink Shared Channel
HS-SCCH	Shared Control Physical Channel for HS-DSCH
MBSFN	MBMS over a Single Frequency Network
Mcps	Mega Chip Per Second
MICH	MBMS Indication Channel
OVSF	Orthogonal Variable Spreading Factor (codes)
PICH	Page Indication Channel
PRACH	Physical Random Access Channel
PSC	Primary Synchronisation Code
RACH	Random Access Channel
SCH	Synchronisation Channel
SSC	Secondary Synchronisation Code
SF	Spreading Factor
UE	User Equipment

4 Uplink spreading and modulation

4.1 Overview

Spreading is applied to the physical channels. It consists of two operations. The first is the channelisation operation, which transforms every data symbol into a number of chips, thus increasing the bandwidth of the signal. The number of chips per data symbol is called the Spreading Factor (SF). The second operation is the scrambling operation, where a scrambling code is applied to the spread signal.

With the channelisation, data symbols on so-called I- and Q-branches are independently multiplied with an OVSF code. With the scrambling operation, the resultant signals on the I- and Q-branches are further multiplied by complex-valued scrambling code, where I and Q denote real and imaginary parts, respectively.

4.2 Spreading

4.2.1 Dedicated physical channels

The possible combinations of the maximum number of respective dedicated physical channels which may be configured simultaneously for a UE in addition to the DPCCH are specified in table 0. The actual UE capability may be lower than the values specified in table 0; the actual dedicated physical channel configuration is indicated by higher layer signalling. The actual number of configured DPDCHs, denoted $N_{\max\text{-dpdch}}$, is equal to the largest number of DPDCHs from all the TFCs in the TFCS. $N_{\max\text{-dpdch}}$ is not changed by frame-by-frame TFCI change or temporary TFC restrictions.

Table 0: Maximum number of simultaneously-configured uplink dedicated channels

	DPDCH	HS-DPCCH	E-DPDCH	E-DPCCH
Case 1	6	1	-	-
Case 2	1	1	2	1
Case 3	-	1	4	1

Figure 1 illustrates the principle of the spreading of uplink dedicated physical channels (DPCCH, DPDCHs, HS-DPCCH, E-DPCCH, E-DPDCHs).

In case of BPSK modulation, the binary input sequences of all physical channels are converted to real valued sequences, i.e. the binary value "0" is mapped to the real value +1, the binary value "1" is mapped to the real value -1, and the value "DTX" (HS-DPCCH only) is mapped to the real value 0.

In case of 4PAM modulation, the binary input sequences of all E-DPDCH physical channels are converted to real valued sequences, i.e. a set of two consecutive binary symbols n_k, n_{k+1} (with $k \bmod 2 = 0$) in each binary sequence is converted to a real valued sequence following the mapping described in Table 0A.

Table 0A: Mapping of E-DPDCH with 4PAM modulation

n_k, n_{k+1}	Mapped real value
00	0.4472
01	1.3416
10	-0.4472
11	-1.3416

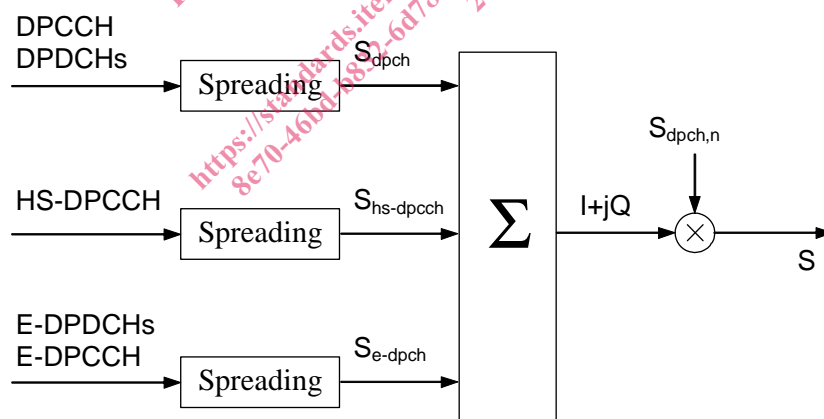
**Figure 1: Spreading for uplink dedicated channels**

The spreading operation is specified in subclauses 4.2.1.1 to 4.2.1.3 for each of the dedicated physical channels; it includes a spreading stage, a weighting stage, and an IQ mapping stage. In the process, the streams of real-valued chips on the I and Q branches are summed; this results in a complex-valued stream of chips for each set of channels.

As described in figure 1, the resulting complex-valued streams S_{dpch} , $S_{hs-dpcch}$ and S_{e-dpch} are summed into a single complex-valued stream which is then scrambled by the complex-valued scrambling code $S_{dpch,n}$. The scrambling code shall be applied aligned with the radio frames, i.e. the first scrambling chip corresponds to the beginning of a radio frame.

NOTE: Although subclause 4.2.1 has been reorganized in this release, the spreading operation for the DPCCH, DPDCH remains unchanged as compared to the previous release.

4.2.1.1 DPCCH/DPDCH

Figure 1a illustrates the spreading operation for the uplink DPCCH and DPDCHs.

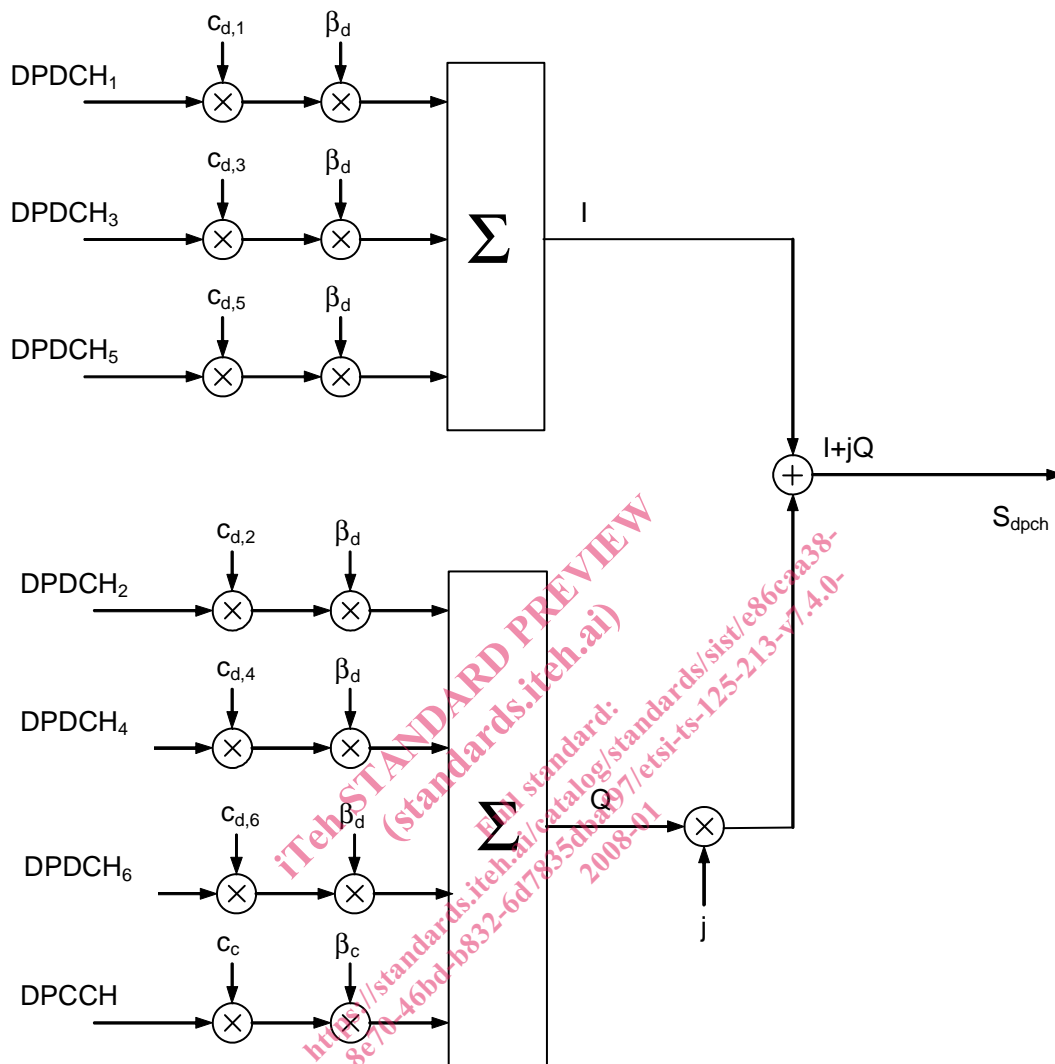

Figure 1A: Spreading for uplink DPCCH/DPDCHs

The DPCCH is spread to the chip rate by the channelisation code c_c . The n -th DPDCH called $DPDCH_n$ is spread to the chip rate by the channelisation code $c_{d,n}$.

After channelisation, the real-valued spread signals are weighted by gain factors, β_c for DPCCH, β_d for all DPDCHs.

The β_c and β_d values are signalled by higher layers or derived as described in [6] 5.1.2.5 and 5.1.2.5C. At every instant in time, at least one of the values β_c and β_d has the amplitude 1.0. The β_c and β_d values are quantized into 4 bit words. The quantization steps are given in table 1.

Table 1: The quantization of the gain parameters

Signalled values for β_c and β_d	Quantized amplitude ratios β_c and β_d
15	1.0
14	14/15
13	13/15
12	12/15
11	11/15
10	10/15
9	9/15
8	8/15
7	7/15
6	6/15
5	5/15
4	4/15
3	3/15
2	2/15
1	1/15
0	Switch off

4.2.1.2 HS-DPCCH

Figure 1b illustrates the spreading operation for the HS-DPCCH.

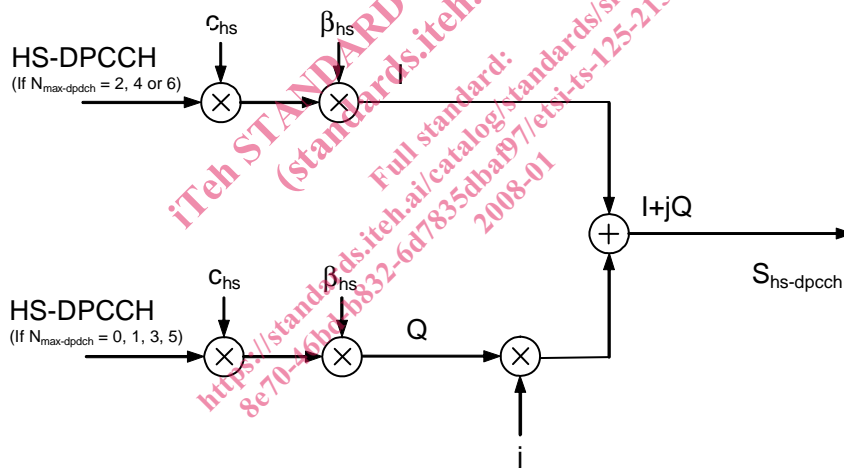

Figure 1B: Spreading for uplink HS-DPCCH

The HS-DPCCH shall be spread to the chip rate by the channelisation code c_{hs} .

After channelisation, the real-valued spread signals are weighted by gain factor β_{hs}

The β_{hs} values are derived from the quantized amplitude ratios A_{hs} which are translated from Δ_{ACK} , Δ_{NACK} and Δ_{CQI} signalled by higher layers as described in [6] 5.1.2.5A.

The translation of Δ_{ACK} , Δ_{NACK} and Δ_{CQI} into quantized amplitude ratios $A_{hs} = \beta_{hs}/\beta_c$ is shown in Table 1A.