

---

---

**Textiles — Measurement of water vapour  
permeability of textiles for the purpose of  
quality control**

*Textiles — Mesurage de la perméabilité à la vapeur d'eau des textiles  
dans le but du contrôle qualité*

**iTeh STANDARD PREVIEW**  
**(standards.iteh.ai)**

ISO 15496:2004

<https://standards.iteh.ai/catalog/standards/sist/b340e6d6-25d0-4e81-a7a3-17e1e0135cfc/iso-15496-2004>



**PDF disclaimer**

This PDF file may contain embedded typefaces. In accordance with Adobe's licensing policy, this file may be printed or viewed but shall not be edited unless the typefaces which are embedded are licensed to and installed on the computer performing the editing. In downloading this file, parties accept therein the responsibility of not infringing Adobe's licensing policy. The ISO Central Secretariat accepts no liability in this area.

Adobe is a trademark of Adobe Systems Incorporated.

Details of the software products used to create this PDF file can be found in the General Info relative to the file; the PDF-creation parameters were optimized for printing. Every care has been taken to ensure that the file is suitable for use by ISO member bodies. In the unlikely event that a problem relating to it is found, please inform the Central Secretariat at the address given below.

**iTeh STANDARD PREVIEW**  
**(standards.iteh.ai)**

[ISO 15496:2004](#)

<https://standards.iteh.ai/catalog/standards/sist/b340e6d6-25d0-4e81-a7a3-17e1e0135cfc/iso-15496-2004>

© ISO 2004

All rights reserved. Unless otherwise specified, no part of this publication may be reproduced or utilized in any form or by any means, electronic or mechanical, including photocopying and microfilm, without permission in writing from either ISO at the address below or ISO's member body in the country of the requester.

ISO copyright office  
Case postale 56 • CH-1211 Geneva 20  
Tel. + 41 22 749 01 11  
Fax + 41 22 749 09 47  
E-mail [copyright@iso.org](mailto:copyright@iso.org)  
Web [www.iso.org](http://www.iso.org)

Published in Switzerland

## Contents

Page

Foreword.....	iv
1 Scope.....	1
2 Terms and definitions.....	1
3 Symbols and units .....	1
4 Principle .....	2
5 Apparatus .....	2
6 Preparation .....	3
7 Test procedure .....	3
8 Calculation and expression of results .....	4
9 Precision of results.....	4
10 Test report .....	5
Annex A (informative) Water vapour permeability — Application of test results .....	8
Annex B (informative) Physical principle behind the test method.....	9
Annex C (informative) Dry desiccant cup methods.....	11
Bibliography .....	12

[ISO 15496:2004](https://standards.iteh.ai/catalog/standards/sist/b340e6d6-25d0-4e81-a7a3-17e1e0135cfc/iso-15496-2004)

<https://standards.iteh.ai/catalog/standards/sist/b340e6d6-25d0-4e81-a7a3-17e1e0135cfc/iso-15496-2004>

## Foreword

ISO (the International Organization for Standardization) is a worldwide federation of national standards bodies (ISO member bodies). The work of preparing International Standards is normally carried out through ISO technical committees. Each member body interested in a subject for which a technical committee has been established has the right to be represented on that committee. International organizations, governmental and non-governmental, in liaison with ISO, also take part in the work. ISO collaborates closely with the International Electrotechnical Commission (IEC) on all matters of electrotechnical standardization.

International Standards are drafted in accordance with the rules given in the ISO/IEC Directives, Part 2.

The main task of technical committees is to prepare International Standards. Draft International Standards adopted by the technical committees are circulated to the member bodies for voting. Publication as an International Standard requires approval by at least 75 % of the member bodies casting a vote.

Attention is drawn to the possibility that some of the elements of this document may be the subject of patent rights. ISO shall not be held responsible for identifying any or all such patent rights.

ISO 15496 was prepared by Technical Committee ISO/TC 38, *Textiles*, Subcommittee SC 2, *Cleansing, finishing and water resistance tests*.

## iTeh STANDARD PREVIEW (standards.iteh.ai)

[ISO 15496:2004](https://standards.iteh.ai/catalog/standards/sist/b340e6d6-25d0-4e81-a7a3-17e1e0135cfc/iso-15496-2004)

<https://standards.iteh.ai/catalog/standards/sist/b340e6d6-25d0-4e81-a7a3-17e1e0135cfc/iso-15496-2004>

# Textiles — Measurement of water vapour permeability of textiles for the purpose of quality control

## 1 Scope

This International Standard describes a comparatively simple method for testing the water vapour permeability of textiles that will provide the manufacturer with a clearly recognized method for quality control within the plant.

The simple test method described in this International Standard is not applicable for classifying the water vapour resistance of textiles against values relating to physiological effects specified in product standards, and particularly not those relating to personal protective equipment.

## 2 Terms and definitions

For the purposes of this document, the following terms and definitions apply.

### 3.1

#### water vapour permeability WVP

characteristic of a textile material describing the amount of water vapour diffusing through the textile per square metre, per hour and per unit difference of water vapour pressure across the textile

## 3 Symbols and units

Symbol	Description	Unit
$a$	Area of the measuring cup opening	m <sup>2</sup>
$\Delta t$	Measuring time	h
$\Delta m$	Change in mass of the measuring cup during the period $\Delta t$	g
$\Delta m_{app}$	Change in mass of the measuring cup on the specimen holder with only membrane during the period $\Delta t$	g
$\Delta p$	Partial water vapour pressure difference across the specimen	Pa
$p_{sa}$	Saturated water vapour pressure at the test room temperature $T_a$	Pa
$p_{sb}$	Saturated water vapour pressure at the water bath temperature $T_b$	Pa
$RH$	Relative humidity in equilibrium with saturated potassium acetate solution	%
$T_a$	Temperature in the test room	°C
$T_b$	Temperature of the water bath	°C
$WVP$	Water vapour permeability of the specimen	g/m <sup>2</sup> ·Pa·h
$WVP_{app}$	Apparatus water vapour permeability	g/m <sup>2</sup> ·Pa·h

## 4 Principle

The specimen to be tested is placed, together with a waterproof but highly water-vapour-permeable, hydrophobic, microporous membrane (henceforth referred to as “membrane”), on a ring holder and then put in a water bath so that the membrane is in contact with the water. This is then left for 15 min. A cup containing saturated potassium acetate solution, creating a relative humidity of about 23 % at the specimen’s upper face, and covered with a second piece of the same membrane, is weighed and then inverted above the specimen in the ring holder, so that the membrane is in contact with the specimen. There will be a net transfer of water vapour through the specimen from the water side to the cup (see Figure 1). After 15 min the cup is taken off and re-weighed. At the same time a control test without a specimen is carried out to determine the water vapour permeability of the two membranes, the apparatus water vapour permeability. The water vapour permeability of the specimen can then be calculated, correcting for the influence of the two membranes.

## 5 Apparatus

The schematics of the test set-up are shown in Figure 1.

### 5.1 Membrane

Any membrane used shall be waterproof, microporous and hydrophobic<sup>1)</sup>. It shall have a high water vapour permeability, so that two layers of the membrane have a water vapour permeability of more than 1,2 g/m<sup>2</sup>·Pa·h when measured according to this International Standard.

### 5.2 Specimen holder

The specimen holder shall be a metal or plastic ring with a milled groove onto which the specimen in conjunction with the membrane is secured, using a rubber ring that fits into the groove, as shown in Figure 2. The rubber ring shall fit tightly so that the specimen and membrane are held under tension. The bottom outside edge of the specimen holder should be radiused.

<https://standards.iteh.ai/catalog/standards/sist/b340e6d6-25d0-4e81-a7a3-17e1e0135cfc/iso-15496-2004>

### 5.3 Support frame for specimen holders

The support frame should consist of two plates, separated by spacers, that support the specimen holders in the water (see Figure 3). Both plates should have at least six holes cut out, those in the top plate being large enough to allow the holder with specimen and membrane to pass through. The holes in the lower plate are smaller than the specimen holder, but larger than the cup opening, and they are centred to the holes in the top plate. The support frame is fitted with four vertically adjustable screws so that the specimen holder can be immersed to a depth of  $(5 \pm 2)$  mm in the water.

The holes in the support frame should be sequentially numbered.

### 5.4 Water bath

The water bath shall consist of a transparent glass or plastic tank, large enough to accommodate the support frame, containing distilled water maintained at  $(23,0 \pm 0,1)$  °C by means of an immersion thermostat with a circulation pump. The water temperature shall be measured in at least four positions simultaneously, adjacent to the four corners of the support frame. In order to obtain a uniform temperature distribution in the water, the inlet or outlet pipe of the thermostat circulation pump shall be extended by means of a hose to the tank end opposite the thermostat. Care should be taken to prevent air bubble formation by either boiling the distilled water prior to use and/or reducing the speed of the thermostat agitator.

---

1) This product is commercially available from, among others: W. L. Gore & Associates GmbH, PO Box 1149, D-85636 Putzbrunn, Germany; Goodfellow Cambridge Ltd., Ermine Business Park, Huntingdon, PE 29 6WR, UK; Goodfellow Corp., 800 Lancaster Av., Berwyn, PA 19312-1780, USA. This information is given for the convenience of users of this International Standard and does not constitute an endorsement by ISO of these products.

**5.5 Measuring cup**, made from transparent plastic and having an internal diameter of between 85 mm and 95 mm, with a tolerance of  $\pm 1$  mm, and a volume of at least 250 ml.

#### 5.6 Potassium acetate solution

Saturated potassium acetate solution shall be made by thoroughly mixing dry potassium acetate (p.a. grade) with distilled water in the ratio of 100 g potassium acetate to 31 g of water. The mixture shall be homogeneous and free of lumps; it shall be allowed to equilibrate at a temperature of  $(23 \pm 3)$  °C for a period of not less than 12 h. It shall be fluid enough to cover the membrane when the cup is inverted prior to testing. The solution shall remain saturated (indicated by its white or opaque appearance) throughout the test.

**5.7 Balance**, capable of determining a mass of approximately 150 g with a precision of  $\pm 1$  mg.

**5.8 Test room**, maintained at  $(23 \pm 3)$  °C.

## 6 Preparation

### 6.1 Specimens

Cut three circular specimens of the textile with diameter of approximately 180 mm. The membrane used as the specimen cover in the specimen holder should have a diameter of approximately 200 mm.

When the specimen is fitted onto the specimen holder, the side that during use would face the body shall be, unless otherwise requested, in contact with the specimen holder's membrane. Specimen and membrane shall be secured without creases or distortion on the specimen holder by means of a rubber ring. There shall be no air gaps between the specimen and membrane. Prepare a control specimen holder with membrane only, so that the apparatus water vapour permeability can be measured.

### 6.2 Measuring cups

Fill each measuring cup with approximately 120 g of the saturated potassium acetate solution and then seal with a circular piece of membrane. For this purpose, briefly roll the edges of the measuring cup against a hot iron or soldering iron, whilst keeping the membrane taut, e.g. by using a rubber band. Excess membrane should be trimmed in order that the contents of the cup can be seen. The cup seal should be tested for leaks prior to each measurement by inverting the cup over absorbent paper for about 3 min, which shall not become wet. The potassium acetate solution shall always be saturated (opaque or white) during the test.

## 7 Test procedure

### 7.1 Inserting the specimen and equilibration

Insert those specimen holders with textile and membrane, and the one with membrane only, into the support frame at  $(30 \pm 5)$  s intervals in sequential order of the holes. Verify that there are no air bubbles between the membrane and water surface. After  $(10 \pm 1)$  min, check the specimens for wrinkles and, if necessary, adjust without removal from the water bath. The specimen holders shall be left on the bath for a total of  $15 \text{ min} \pm 10 \text{ s}$  before the measuring cup is placed on the specimen.

### 7.2 Placing the measuring cups on the bath

Weigh ( $m_0$ ) the measuring cups, invert and gently shake them to spread the potassium acetate solution evenly over the membrane, then centre them on the specimen surface at time intervals of  $(30 \pm 5)$  s, in the same order as the specimen holders were inserted into the support frame. Centre one cup on the control specimen holder with membrane only. Remove each cup  $15 \text{ min} \pm 10 \text{ s}$  after having placed it on the specimen, and re-weigh ( $m_{15}$ ) it.

### 7.3 Check for waterproofness of the specimen holder membrane

Remove the specimen from the specimen holder and examine the membrane and the specimen for evidence of water leakage. If water leakage occurred, that particular specimen's value shall be excluded from the evaluation.

## 8 Calculation and expression of results

Calculate the water vapour permeability (WVP) of the specimen using Equations (1) to (3) (see Clause 3 for explanation of symbols):

$$\Delta m = m_{15} - m_0 \quad (1)$$

$$WVP_{app} = \frac{\Delta m_{app}}{a \times \Delta p \times \Delta t} \quad (2)$$

$$WVP = \left( \frac{a \times \Delta p \times \Delta t}{\Delta m} - \frac{1}{WVP_{app}} \right) - 1 \quad (3)$$

The relative humidity in equilibrium with saturated potassium acetate solution at temperature  $T_a$ , expressed as a percentage, is [1]

$$RH = 22,438 8 + 0,156 288 \times T_a - (0,612 868 \times 10^{-2}) \times T_a^2$$

**STANDARD PREVIEW**  
**(standards.iteh.ai)**

If  $T_a = T_b = 23,0$  °C, then  $RH = 22,8$  %

ISO 15496:2004

[https://standards.iteh.ai/catalog/standards/sist/b40e6d6-25d0-4e81-a7a3-](https://standards.iteh.ai/catalog/standards/sist/b40e6d6-25d0-4e81-a7a3-17e1e0135cf/iso-15496-2004)

and then,  $\Delta p = p_{sb} - \frac{p_{sa} \times RH}{100} = (2 808 - 640) \text{ Pa} = 2 168 \text{ Pa}$ .

## 9 Precision of results

### 9.1 Repeatability

Six laboratories tested two fabrics three times each. The mean of the standard deviation was 0,007 g/m<sup>2</sup>·Pa·h.

### 9.2 Reproducibility

Six laboratories testing four specimens of four different fabrics with water vapour permeability ranging from 0,08 g/m<sup>2</sup>·Pa·h to 0,24 g/m<sup>2</sup>·Pa·h showed a standard deviation of 0,011 g/m<sup>2</sup>·Pa·h.



## 10 Test report

The test report shall include at least the following information:

- all information necessary for identification of the sample tested;
- reference to this International Standard;
- description of the test sample;
- orientation of the test specimens according to 6.1;
- number of test specimens per sample;
- temperature in the test room  $T_a$  and of the water bath  $T_b$  during the test period;
- partial water vapour pressure difference across the specimens,  $\Delta p$ ;
- arithmetic mean of the water vapour permeability,  $WVP$ ;
- $WVP_{app}$  of the test apparatus;
- any deviations from the procedure specified;
- any unusual features (anomalies) observed during the test;
- date of test.

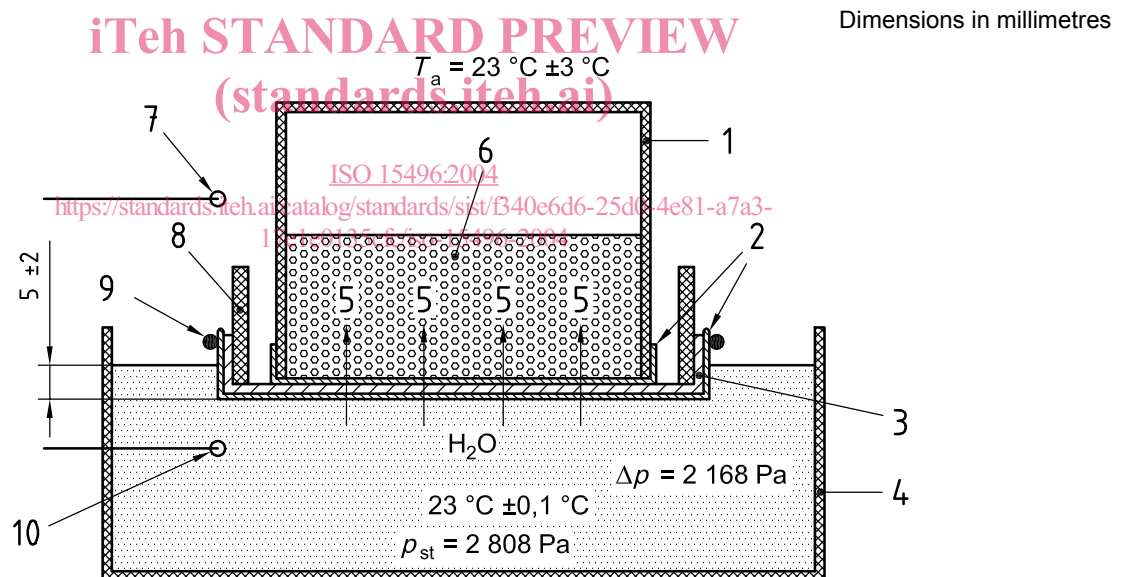

### Key

- measuring cup
- membrane
- textile specimen
- water tank
- water vapour
- saturated potassium acetate solution
- temperature sensor for  $T_a$
- specimen holder
- rubber ring
- temperature sensor

**Figure 1 — Schematical test arrangement for the cup method**