

---

5 YfcbUj h\_U!?'cbY\_lcf1žcdh] b]ždfUj c\_cfb]ža cXi`Ufb]žj Y\_cbHJ\_hb]ždfYa Yf  
\_Ud]WY`%&) žg'gbYa`lj c`Wbhf]fbc`di ýc`!`%\$&"XY.`Cdh] b]\_cbHJ\_hnU\_UVY`9B`(\* (%  
!%\$&!`8 Ycj bYhYa dYfUi fY'a YX`!)`š7`]b`%\$\$ š7`!`GHubXUfX`nUdfc]nj cX

Aerospace series - Connectors, optical, rectangular, modular, multicontact, 1,25 diameter ferrule, with removable alignment sleeve holder - Part 102: Optical contact for cable EN 4641-102 - Operating temperatures between - 55 °C and 100 °C - Product standard

### **iTeh STANDARD PREVIEW**

Luft- und Raumfahrt - Optischer Rechtecksteckverbinder, modular, Mehrfachkontakt, Ferrulendurchmesser 1,25 mm, demontierbarer Zentrierhülsenhalter - Teil 102: Optische Kontakt für EN 4641-102 Kabel - Betriebstemperaturen zwischen - 55 °C und 100 °C - Produktnorm

<https://standards.iteh.ai/catalog/standards/sist/fd0e7604-ccfa-4334-b69d-9b1876aeac75/sist-en-4639-102-2008>

Série aérospatiale - Connecteurs optiques rectangulaires, modulaires multicontacts, férule 1,25, équipés d'un porte sleeve démontable - Partie 102 : Contact optique pour câble EN 4641-102 - Températures de fonctionnement comprises entre - 55 °C et 100 °C - Norme de produit

**Ta slovenski standard je istoveten z: EN 4639-102:2007**

---

**ICS:**

49.060

**SIST EN 4639-102:2008**

**en**

# **iTeh STANDARD PREVIEW** **(standards.iteh.ai)**

SIST EN 4639-102:2008

<https://standards.iteh.ai/catalog/standards/sist/fd0e7604-ccfa-4334-b69d-9b1876aeac75/sist-en-4639-102-2008>

ICS 49.060

English Version

Aerospace series - Connectors, optical, rectangular, modular,  
multicontact, 1,25 diameter ferrule, with removable alignment  
sleeve holder - Part 102: Optical contact for cable EN 4641-102  
- Operating temperatures between - 55 °C and 100 °C - Product  
standard

Série aérospatiale - Connecteurs optiques rectangulaires,  
modulaires multicontacts, fêrulle 1,25, équipés d'un porte  
sleeve démontable - Partie 102 : Contact optique pour  
câble EN 4641-102 - Températures de fonctionnement  
comprises entre - 55 °C et 100 °C - Norme de produit

Luft- und Raumfahrt - Optischer Rechtecksteckverbinder,  
modular, Mehrfachkontakt, Ferrulendurchmesser 1,25 mm,  
demonrierbarer Zentrierhülsehalter - Teil 102: Optische  
Kontakt für EN 4641-102 Kabel - Betriebstemperaturen  
zwischen - 55 °C und 100 °C - Produktnorm

This European Standard was approved by CEN on 21 June 2007.

CEN members are bound to comply with the CEN/CENELEC Internal Regulations which stipulate the conditions for giving this European Standard the status of a national standard without any alteration. Up-to-date lists and bibliographical references concerning such national standards may be obtained on application to the CEN Management Centre or to any CEN member.

This European Standard exists in three official versions (English, French, German). A version in any other language made by translation under the responsibility of a CEN member into its own language and notified to the CEN Management Centre has the same status as the official versions.

CEN members are the national standards bodies of Austria, Belgium, Bulgaria, Cyprus, Czech Republic, Denmark, Estonia, Finland, France, Germany, Greece, Hungary, Iceland, Ireland, Italy, Latvia, Lithuania, Luxembourg, Malta, Netherlands, Norway, Poland, Portugal, Romania, Slovakia, Slovenia, Spain, Sweden, Switzerland and United Kingdom.



EUROPEAN COMMITTEE FOR STANDARDIZATION  
COMITÉ EUROPÉEN DE NORMALISATION  
EUROPÄISCHES KOMITEE FÜR NORMUNG

Management Centre: rue de Stassart, 36 B-1050 Brussels

## Contents

Page

Foreword.....	3
1 Scope .....	4
2 Normative references .....	4
3 Fibre optic contact designation and dimensions.....	4
3.1 Contact designation .....	4
3.2 Contact dimensions.....	4
3.3 Cable designation .....	6
4 Technical specification .....	6
5 Tests according to EN 2591-100.....	6
6 Assembly process instructions .....	7
6.1 Cleaning instructions .....	7
6.2 Tooling .....	7
6.3 Termination instructions.....	7
7 Designation .....	8

**iTeh STANDARD PREVIEW**  
**(standards.iteh.ai)**

SIST EN 4639-102:2008

<https://standards.iteh.ai/catalog/standards/sist/fd0e7604-ccfa-4334-b69d-9b1876aeac75/sist-en-4639-102-2008>

## Foreword

This document (EN 4639-102:2007) has been prepared by the Aerospace and Defence Industries Association of Europe - Standardization (ASD-STAN).

After enquiries and votes carried out in accordance with the rules of this Association, this Standard has received the approval of the National Associations and the Official Services of the member countries of ASD, prior to its presentation to CEN.

This European Standard shall be given the status of a national standard, either by publication of an identical text or by endorsement, at the latest by June 2008, and conflicting national standards shall be withdrawn at the latest by June 2008.

Attention is drawn to the possibility that some of the elements of this document may be the subject of patent rights. CEN [and/or CENELEC] shall not be held responsible for identifying any or all such patent rights.

According to the CEN/CENELEC Internal Regulations, the national standards organizations of the following countries are bound to implement this European Standard: Austria, Belgium, Bulgaria, Cyprus, Czech Republic, Denmark, Estonia, Finland, France, Germany, Greece, Hungary, Iceland, Ireland, Italy, Latvia, Lithuania, Luxembourg, Malta, Netherlands, Norway, Poland, Portugal, Romania, Slovakia, Slovenia, Spain, Sweden, Switzerland and the United Kingdom.

**ITEH STANDARD PREVIEW**  
**(standards.iteh.ai)**

[SIST EN 4639-102:2008](https://standards.iteh.ai/catalog/standards/sist/fd0e7604-ccfa-4334-b69d-9b1876aeac75/sist-en-4639-102-2008)

<https://standards.iteh.ai/catalog/standards/sist/fd0e7604-ccfa-4334-b69d-9b1876aeac75/sist-en-4639-102-2008>

# 1 Scope

This standard defines the performance and dimensions of optical physical contact for EN 4641-102 cable specification.

# 2 Normative references

The following referenced documents are indispensable for the application of this document. For dated references, only the edition cited applies. For undated references, the latest edition of the referenced document (including any amendments) applies.

EN 2591-\*, *Aerospace series — Elements of electrical and optical connection — Test methods.*

EN 4639-001, *Aerospace series — Connectors, optical, rectangular, modular, multicontact, 1,25 diameter ferrule, with removable alignment sleeve holder — Part 001: Technical specification.*

EN 4639-002, *Aerospace series — Connectors, optical, rectangular, modular, multicontact, 1,25 diameter ferrule, with removable alignment sleeve holder — Part 002: List of product standards.*

EN 4641-102, *Aerospace series — Cable optical — 125 µm diameter cladding — Part 102: Outer diameter 1,8 mm, semi loose structure — Product standard.* <sup>1)</sup>

MIL-I-81969/14, *Installing and removal tools, connector electrical contact, type III, class 2, composition B.* <sup>2)</sup>

TR 4647, *Aerospace series — Fibres and cables, optical aircraft use — Technical Report — Termination procedure for EN 4639 10X contact.* <sup>1)</sup>

STANDARD PREVIEW  
(standards.iteh.ai)

SIST EN 4639-102:2008

<https://standards.iteh.ai/catalog/standards/sist/f10e7604-ccfa-4334-b69d-9b1876aeac75/sist-en-4639-102-2008>

# 3 Fibre optic contact designation and dimensions

## 3.1 Contact designation

See Table 1.

Table 1

Contact designation	Contact type	Cable structure type
Fibre optic contact for semi loose structure cable	ML	EN 4641-102

## 3.2 Contact dimensions

Dimensions and tolerances are in millimetres, see Figure 1.

\* All parts quoted in this standard.

1) In preparation at the date of publication of this standard.

2) Published by: Department of Defence (DOD), the Pentagon, Washington D.C. 20301 USA.

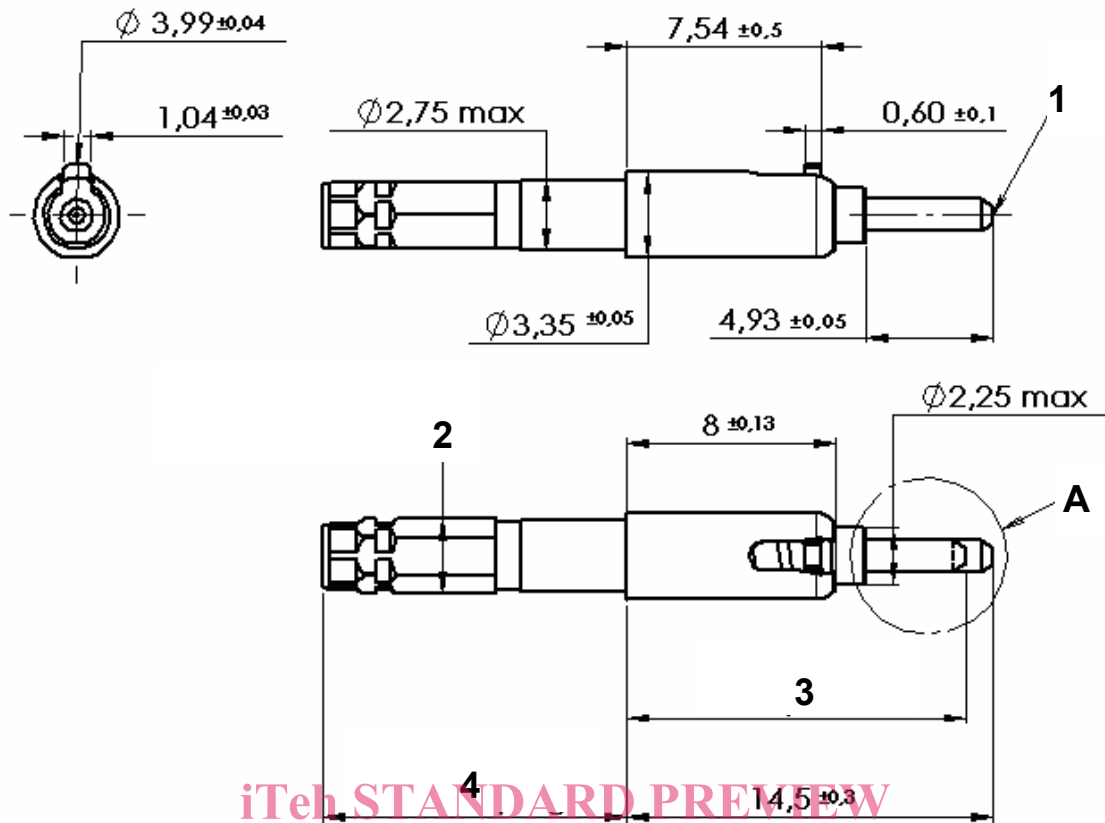

**STANDARD PREVIEW**  
 (standards.iteh.ai)

Spring force when connector is mated:

Typical: 5,65 N (minimum 4,6 N, maximum 6,7 N)

<https://standards.iteh.ai/catalog/standards/sist/fd0e7604-ccfa-4334-b69d-9b1876aeac75/sist-en-4639-102-2008>

**View A**

Multimode ferrule for 125 µm fibre

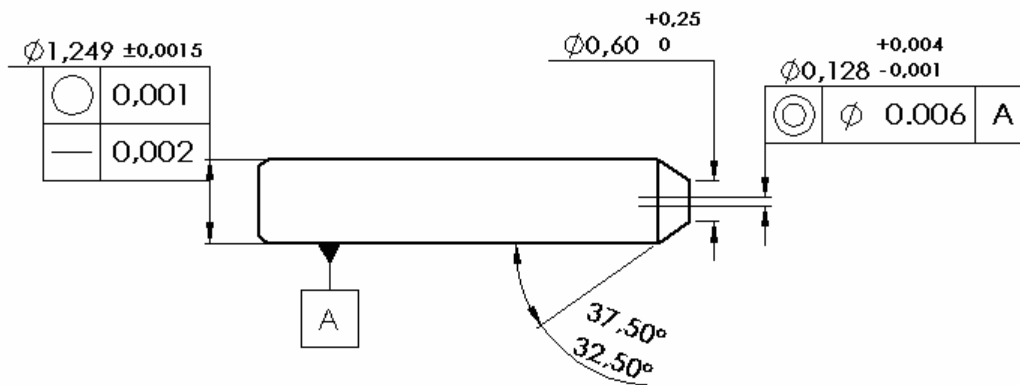

**Key**

- 1 Optical reference plane
- 2  $\varnothing$  2,95 max. after crimping
- 3 13,15 max. – Back position
- 4 12,3 max. – After crimping – Free position

**Figure 1**

### 3.3 Cable designation

Specified in EN 4641-102.

## 4 Technical specification

This component is qualified as part of a complete connector assembly when tested according to the qualification requirements of EN 4639-001 and the applicable product standards.

## 5 Tests according to EN 2591-100

The tests of EN 2591-100, applicable in the context of this standard as well as the details necessary for implementing them and for inspecting connector characteristics, are given in Table 2.

Environmental tests are specified in EN 4639-001.

Table 2

EN 2591-	Test	Details
6301	Endurance at temperature	1 000 hours at 100 °C
301	Endurance at temperature	Not applicable
304	Damp heat steady state	Temperature of 40 °C and 93 % of humidity
6305	Rapid change of temperature	10 cycles, $T_A = 100\text{ °C}$ , $T_B = -55\text{ °C}$
6307	Salt mist	Mated connectors – Severity according to environmental class of the connector
309	Dry heat	Not applicable
310	Cold	Not applicable
311	Low air pressure	Not applicable
313	Driving rain (artificial)	Not applicable
6316	Ozone resistance	Not applicable
320	Simulated solar radiation at ground level	Not applicable
6401	Acceleration steady state	Not applicable
6405	Axial load	100 N maintained for 1 minute, 3 cycles
6406	Mechanical endurance	500 mating/unmating cycles
407	Durability of contact retention system and seals (maintenance aging)	Applicable
601	Insertion loss	0,7 dB max. during and after tests
602	Variation of attenuation and optical discontinuity	Method A, IL maximum = 0,7 dB
604	Cleaning capability of optical face	Applicable
605	Return loss	RL < - 21 dB
607	Immunity to ambient light coupling	Not applicable
608	Nuclear radiation	Not applicable
609	Effectiveness of cable attachment – Cable cyclic flexing	100 cycles at load of 40 N
610	Effectiveness of cable attachment – Cable pulling	Method B, 68 N tensile load, 1 minute, 3 pulls
611	Effectiveness of cable attachment – Cable torsion	100 cycles at load of 40 N
612	Effectiveness of cable attachment – Cable axial compression	Compression force of 10 N for 2 minutes



EN 2591-	Test	Details
613	Impact test	Severity: light
615	Connection integrity at temperature	Not applicable
617	Temperature cycling	10 cycles, $T_A = 100\text{ °C}$ , $T_B = -55\text{ °C}$

## 6 Assembly process instructions

### 6.1 Cleaning instructions

This fibre optic connector provides an easy access to the optical faces and sleeves for cleaning.

Cleaning operation can be performed as follows:

1. Unmate the pair of connectors.
2. Remove the sleeve holder (From the female insert).
3. Use cleaning stick and pipe with ethylic alcohol (or equivalent) to clean the front face of the optical contact and the inside of the sleeve without removing the contacts from their cavities.
4. Use dry clean air can for drying.
5. Inspect optical face
6. Install the sleeve holder (From the female insert).
7. Mate the pair of connectors.

See TR 4647 for details.

### 6.2 Tooling

For insertion and extraction of the optical contact use the standard tool as per MIL-I-81969/14-3 standard (P/N for size 16).

### 6.3 Termination instructions

General termination operation:

1. Pass the cable through the crimping ferrule.
2. Strip the cable down to the 125  $\mu\text{m}$  fibre.
3. Inject epoxy glue with adapted syringe inside the optical ferrule from the front side.
4. Insert the optical contact onto the fibre and the cable.
5. Slide and crimp the rear ferrule onto the body contact, the cable and its strength members.
6. Cure the epoxy glue with an appropriate cure oven.
7. Cleave the fibre and polish the front face of the optical contact.
8. Inspection and control.

See TR 4647 for details.