

---

**Specifikacija geometrijskih veličin izdelka - Geometrijske značilnosti - 2. del:  
Povzeta srednja linija valja in stožca, povzeta srednja površina, lokalna velikost  
povzete značilnosti**

Geometrical Product Specifications (GPS) -- Geometrical features -- Part 2: Extracted median line of a cylinder and a cone, extracted median surface, local size of an extracted feature

**iTeh STANDARD PREVIEW**  
**(standards.iteh.ai)**

Spécification géométrique des produits (GPS) -- Éléments géométriques -- Partie 2:  
Ligne médiane extraite d'un cylindre et d'un cône, surface médiane extraite, taille locale  
d'un élément extrait

**Ta slovenski standard je istoveten z: ISO 14660-2:1999**

---

**ICS:**

|           |  |  |
|-----------|--|--|
| 01.040.17 | Meroslovje in merjenje.<br>Fizikalni pojavi (Slovarji) | Metrology and measurement.<br>Physical phenomena<br>(Vocabularies) |
| 17.040.40 | Specifikacija geometrijskih<br>veličin izdelka (GPS)   | Geometrical Product<br>Specification (GPS)                         |

**SIST ISO 14660-2:2002****en**

**iTeh STANDARD PREVIEW**  
**(standards.iteh.ai)**

SIST ISO 14660-2:2002

<https://standards.iteh.ai/catalog/standards/sist/cc349251-5c3a-4cc7-9b5f-7aaf635ad330/sist-iso-14660-2-2002>

# INTERNATIONAL STANDARD

# ISO 14660-2

First edition  
1999-10-01

---

---

## Geometrical Product Specifications (GPS) — Geometrical features —

### Part 2:

Extracted median line of a cylinder and  
a cone, extracted median surface, local size of  
(an extracted feature)

*Spécification géométrique des produits (GPS) — Éléments géométriques —*  
[https://standards.iteh.ai/catalog/standards/sist/cc349251-5c3a-4cc7-9b5f-](https://standards.iteh.ai/catalog/standards/sist/cc349251-5c3a-4cc7-9b5f-14660-2)

*Partie 2: Ligne médiane extraite d'un cylindre et d'un cône, surface médiane  
extraite, taille locale d'un élément extrait*



Reference number  
ISO 14660-2:1999(E)

**ISO 14660-2:1999(E)****Foreword**

ISO (the International Organization for Standardization) is a worldwide federation of national standards bodies (ISO member bodies). The work of preparing International Standards is normally carried out through ISO technical committees. Each member body interested in a subject for which a technical committee has been established has the right to be represented on that committee. International organizations, governmental and non-governmental, in liaison with ISO, also take part in the work. ISO collaborates closely with the International Electrotechnical Commission (IEC) on all matters of electrotechnical standardization.

International Standards are drafted in accordance with the rules given in the ISO/IEC Directives, Part 3.

Draft International Standards adopted by the technical committees are circulated to the member bodies for voting. Publication as an International Standard requires approval by at least 75 % of the member bodies casting a vote.

International Standard ISO 14660-2 was prepared by Technical Committee ISO/TC 213, *Dimensional and geometrical product specifications and verification*.

ISO 14660 consists of the following parts, under the general title *Geometrical product specifications (GPS) — Geometrical features*:

- *Part 1: General terms and definitions*
- *Part 2: Extracted median line of a cylinder and a cone, extracted median surface, local size of an extracted feature*

Annex A of this part of ISO 14660 is for information only.

**iteh STANDARD PREVIEW**  
**(standards.iteh.ai)**  
<https://standards.iteh.ai/catalog/standards/sist/cc349251-5c3a-4cc7-9b5f-7aaf635ad330/sist-iso-14660-2-2002>

© ISO 1999

All rights reserved. Unless otherwise specified, no part of this publication may be reproduced or utilized in any form or by any means, electronic or mechanical, including photocopying and microfilm, without permission in writing from the publisher.

International Organization for Standardization  
Case postale 56 • CH-1211 Genève 20 • Switzerland  
Internet iso@iso.ch

Printed in Switzerland

## Introduction

This part of ISO 14660 is a geometrical product specification (GPS) standard and is to be regarded as a general GPS standard (see ISO/TR 14638). It influences chain link 3 of the Size, Form of line — Derived feature, Form of surface — Derived feature, Orientation — Derived feature and Location — Derived feature chains of standards in the general GPS matrix.

For more detailed information on the relation of this part of ISO 14660 to other standards and the GPS matrix model, see annex A.

Geometrical features exist in three “worlds”:

- the world of specification, where several representations of the future workpiece are imagined by the designer;
- the world of the workpiece, the physical world;
- the world of inspection, where a representation of a given workpiece is used through sampling of the workpiece by measuring instruments.

It is important to understand the relationship between these three worlds. ISO 14660 defines standardized terminology for geometrical features in each world as well as standardized terminology for the relationship and communication between each world.

This part of ISO 14660 is part 2 of a series of standards under preparation dealing with geometrical feature definitions.

Extracted features are not geometrical perfect and need further detailed definitions compared to the corresponding nominal features to be unambiguous defined and correctly understood.

It is the intention that the same detailed definition of an extracted feature is valid in all chains of standards where the feature or characteristic is used. Therefore the definitions given in this part of ISO 14660 are in force wherever they apply in the general GPS matrix.

For the purposes of this part of ISO 14660, the following line types have been used in the illustrations:

| Feature type  | Line type                     |
|---|-------------------------------|
| <ul style="list-style-type: none"> <li>• extracted surface</li> <li>• extracted line (integral features)</li> </ul>   | wide dotted line              |
| <ul style="list-style-type: none"> <li>• extracted median surface</li> <li>• extracted median line (derived features)</li> </ul>                                    | narrow dotted line            |
| <ul style="list-style-type: none"> <li>• associated plane of a extracted (integral) surface</li> <li>• associated line in a extracted (integral) surface</li> </ul> | wide dashed dotted line       |
| <ul style="list-style-type: none"> <li>• associated median plane, associated axis (derived features)</li> </ul>   | narrow dashed dotted line     |
| <ul style="list-style-type: none"> <li>• real surface (outline)</li> </ul>  | continuous wide line          |
| <ul style="list-style-type: none"> <li>• nominal features (technical drawings in illustrations)</li> </ul>  | in accordance with ISO 128-24 |

**iTeh STANDARD PREVIEW**  
**(standards.iteh.ai)**

SIST ISO 14660-2:2002

<https://standards.iteh.ai/catalog/standards/sist/cc349251-5c3a-4cc7-9b5f-7aaf635ad330/sist-iso-14660-2-2002>

# Geometrical Product Specifications (GPS) — Geometrical features —

## Part 2:

Extracted median line of a cylinder and a cone, extracted median surface, local size of an extracted feature

### 1 Scope

This part of ISO 14660 defines a number of extracted features of workpieces. It specifies conditions for default definitions, i.e. when no other definitions are specified on the drawing by an extended feature indication. This part of ISO 14660 does not give further definitions, for the extracted feature in question, which would require extended drawing indications.

### 2 Normative reference

[SIST ISO 14660-2:2002](https://standards.iteh.ai/catalog/standards/sist/cc349251-5c3a-4cc7-9b5f-7aaf635ad330/sist-iso-14660-2-2002)

<https://standards.iteh.ai/catalog/standards/sist/cc349251-5c3a-4cc7-9b5f-7aaf635ad330/sist-iso-14660-2-2002>

The following normative document contains provisions which, through reference in this text, constitute provisions of this part of ISO 14660. For dated references, subsequent amendments to, or revisions of, any of these publications do not apply. However, parties to agreements based on this part of ISO 14660 are encouraged to investigate the possibility of applying the most recent edition of the normative document indicated below. For undated references, the latest edition of the normative document referred to applies. Members of ISO and IEC maintain registers of currently valid International Standards.

ISO 14660-1:1999, *Geometrical product specifications (GPS) — Geometrical features — Part 1: General terms and definitions*.

### 3 Terms and definitions

For the purposes of this part of ISO 14660, the terms and definitions given in ISO 14660-1 and the following apply.

#### 3.1

##### **default definition (of an extracted feature)**

detailed supplementary definition, selected by convention, of the extracted feature concerned, which is applicable only by using the basic ISO tolerance indication on the drawing or in other technical documents

NOTE 1 The basic ISO tolerance indications are those given in, for example, ISO 286-1, ISO 1101 and ISO 1302.

NOTE 2 The default definition (of an extracted feature) can be changed to a special definition by adding an extension to the basic ISO tolerance indication. Such extensions are under development.

**3.2****extracted median line of a cylinder**

locus of centres of cross-sections, where

- the centres of cross-sections are centres of associated circles; and
- the cross-sections are perpendicular to the axis of the associated cylinder obtained from the extracted surface (i.e. the radius could be different from the nominal radius)

**3.3****extracted median line of a cone**

locus of centres of cross-sections, where

- the centres of cross-sections are centres of associated circles; and
- the cross-sections are perpendicular to the axis of the associated cone obtained from the extracted surface (i.e. the angle could be different from the nominal angle)

**3.4****extracted median surface**

locus of centrepoinets between sets of opposite points of the opposite extracted surfaces, where

- the connecting lines of sets of opposite points are perpendicular to the associated median plane; and
- the associated median plane is the median plane of two associated parallel planes obtained from the extracted surfaces (i.e. the distance between the two associated parallel planes could be different from the nominal distance)

**3.5****local size of an extracted cylinder****local diameter of an extracted cylinder**

distance between two opposite points on the feature, where

- the connection line between the points includes the associated circle centre; and
- the cross-sections are perpendicular to the axis of the associated cylinder obtained from the extracted surface

**3.6****local size of two parallel extracted surfaces**

distance between two points on opposite extracted surfaces, where

- the connecting lines of sets of opposite points are perpendicular to the associated median plane; and
- the associated median plane is the median plane of two associated parallel planes obtained from the extracted surfaces (i.e. the distance between the two associated parallel planes could be different from the nominal distance)

**4 Default definition conditions****4.1 Extracted derived features****4.1.1 Extracted median line of a cylinder**

For the default definition (unless otherwise specified) of the extracted median line of a cylinder, the following conditions apply:

- the associated circles are the total least squares circles (see Figure 1);
- the associated cylinder is the total least squares cylinder (see Figure 1).



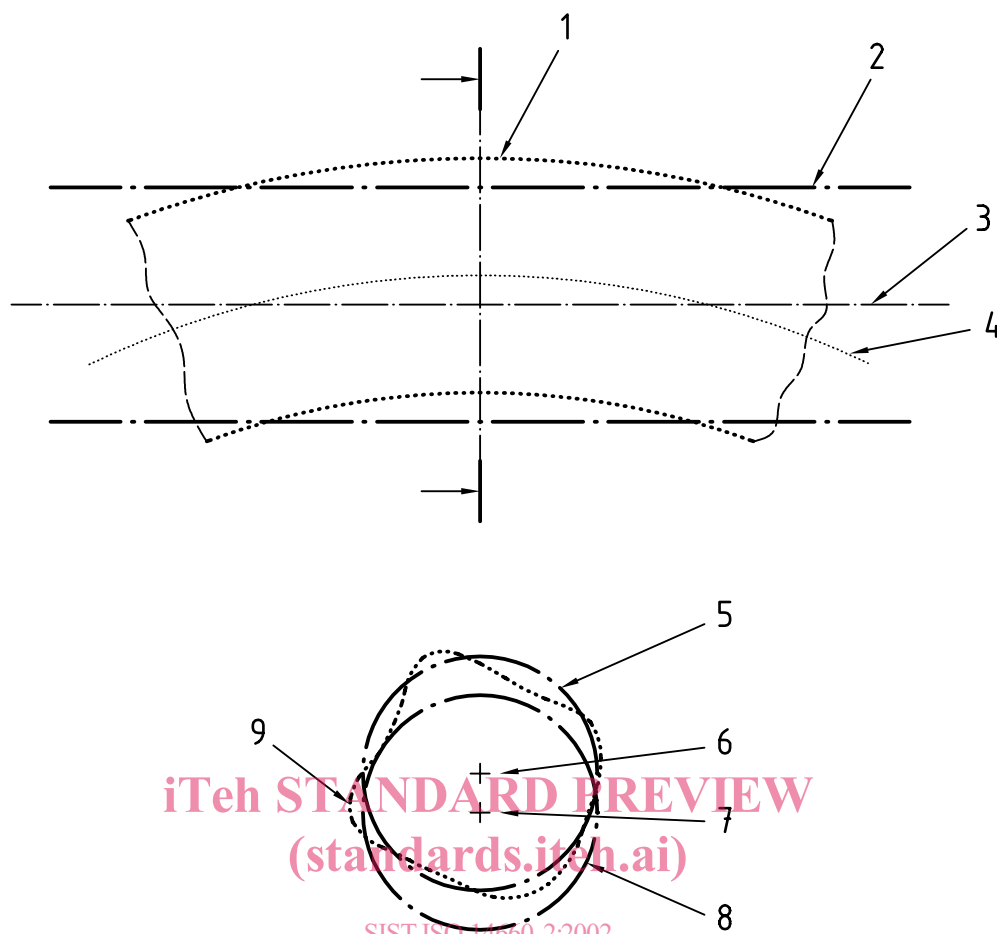

iTeh STANDARD PREVIEW  
(standards.iteh.ai)

SIST ISO 14660-2:2002

<https://standards.iteh.ai/catalog/standards/sist/cc349251-5c3a-4cc7-9b5f-7aaf635ad330/sist-iso-14660-2-2002>

**Key**

- 1 Extracted surface
- 2 Associated cylinder
- 3 Associated cylinder axis
- 4 Extracted median line
- 5 Associated circle
- 6 Associated circle centre
- 7 Associated cylinder axis
- 8 Associated cylinder
- 9 Extracted line

**Figure 1 — Extracted median line of a cylinder**