



Designation: D 559 – 96

Standard Test Methods for Wetting and Drying Compacted Soil-Cement Mixtures¹

This standard is issued under the fixed designation D 559; the number immediately following the designation indicates the year of original adoption or, in the case of revision, the year of last revision. A number in parentheses indicates the year of last reappraisal. A superscript epsilon (ϵ) indicates an editorial change since the last revision or reappraisal.

This standard has been approved for use by agencies of the Department of Defense.

1. Scope *

1.1 These test methods cover procedures for determining the soil-cement losses, water content changes, and volume changes (swell and shrinkage) produced by repeated wetting and drying of hardened soil-cement specimens. The specimens are compacted in a mold, before cement hydration, to maximum density at optimum water content using the compaction procedure described in Test Methods D 558.

1.2 Two test methods, depending on soil gradation, are covered for preparation of material for molding specimens and for molding specimens as follows:

	Sections
Test Method A, using soil material passing a No. 4 (4.75-mm) sieve. This method shall be used when 100 % of the soil sample passes the No. 4 (4.75-mm) sieve	5
Test Method B, using soil material passing a 3/4-in. (19.0-mm) sieve. This method shall be used when part of the soil sample is retained on the No. 4 (4.75-mm) sieve. This test method may be used only on materials with 30 % or less retained on the 3/4-in. (19.0-mm) sieve.	6

1.3 The values stated in inch-pound units are to be regarded as the standard. The SI units given in parentheses are for information only.

1.4 *This standard does not purport to address all of the safety concerns, if any, associated with its use. It is the responsibility of the user of this standard to establish appropriate safety and health practices and determine the applicability of regulatory limitations prior to use.*

2. Referenced Documents

2.1 ASTM Standards:

- C 150 Specification for Portland Cement²
- C 595 Specification for Blended Hydraulic Cements²
- D 558 Test Methods for Moisture-Density Relations of Soil-Cement Mixtures³
- D 560 Test Methods for Freezing-and-Thawing Tests of Compacted Soil-Cement Mixtures³

D 2168 Test Methods for Calibration of Laboratory Mechanical-Rammer Soil Compactors³

D 3740 Practice for the Minimum Requirements for Agencies Engaged in the Testing and/or Inspection of Soil and Rock Used in Engineering Design and Construction³

E 11 Specification for Wire-Cloth Sieves for Testing Purposes⁴

3. Significance and Use

3.1 These test methods are used to determine the resistance of compacted soil-cement specimens to repeated wetting and drying. These test methods were developed to be used in conjunction with Test Methods D 560 and criteria given in the *Soil-Cement Laboratory Handbook*⁵ to determine the minimum amount of cement required in soil-cement to achieve a degree of hardness adequate to resist field weathering.

NOTE 1—The agency performing these test methods can be evaluated in accordance with Practice D 3740. Notwithstanding statements on precision and bias contained in these test methods: the precision of these test methods is dependent on the competence of the personnel performing it and the suitability of the equipment and facilities used. Agencies that meet the criteria of Practice D 3740 are generally considered capable of competent and objective testing. Users of these test methods are cautioned that compliance with Practice D 3740 does not, in itself, ensure reliable testing. Reliable testing depends on many factors; Practice D 3740 provides a means of evaluating some of these factors.

4. Apparatus

4.1 *Mold*—A cylindrical metal mold having a capacity of $\frac{1}{30} \pm 0.0004 \text{ ft}^3$ ($944 \pm 11 \text{ cm}^3$) with an internal diameter of $4.0 \pm 0.016 \text{ in.}$ ($101.60 \pm 0.41 \text{ mm}$) and conforming to Fig. 1 to permit preparing compacted specimens of soil-cement mixtures of this size. The mold shall be provided with a detachable collar assembly approximately $2\frac{1}{2} \text{ in.}$ (63.5 mm) in height. The mold may be of the split type consisting of two half-round sections or a section of pipe with one side split perpendicular to the pipe circumference and that can be securely locked in place to form a closed cylinder having the dimensions described above. The mold and collar assembly shall be so constructed that it can be fastened firmly to a detachable base.

¹ These test methods are under the jurisdiction of the ASTM Committee D-18 on Soil and Rock and are the direct responsibility of Subcommittee D18.15 on Stabilization of Additives.

Current edition approved May 10, 1996. Published July 1996. Originally published as D 559 – 39. Last previous edition D 559 – 89.

² *Annual Book of ASTM Standards*, Vols 04.01 and 04.02.

³ *Annual Book of ASTM Standards*, Vol 04.08.

⁴ *Annual Book of ASTM Standards*, Vols 04.01, 04.06, and 14.02.

⁵ *Soil-Cement Laboratory Handbook*, Portland Cement Assn., 1971.

*A Summary of Changes section appears at the end of this standard.

ASTM D 559 - 96

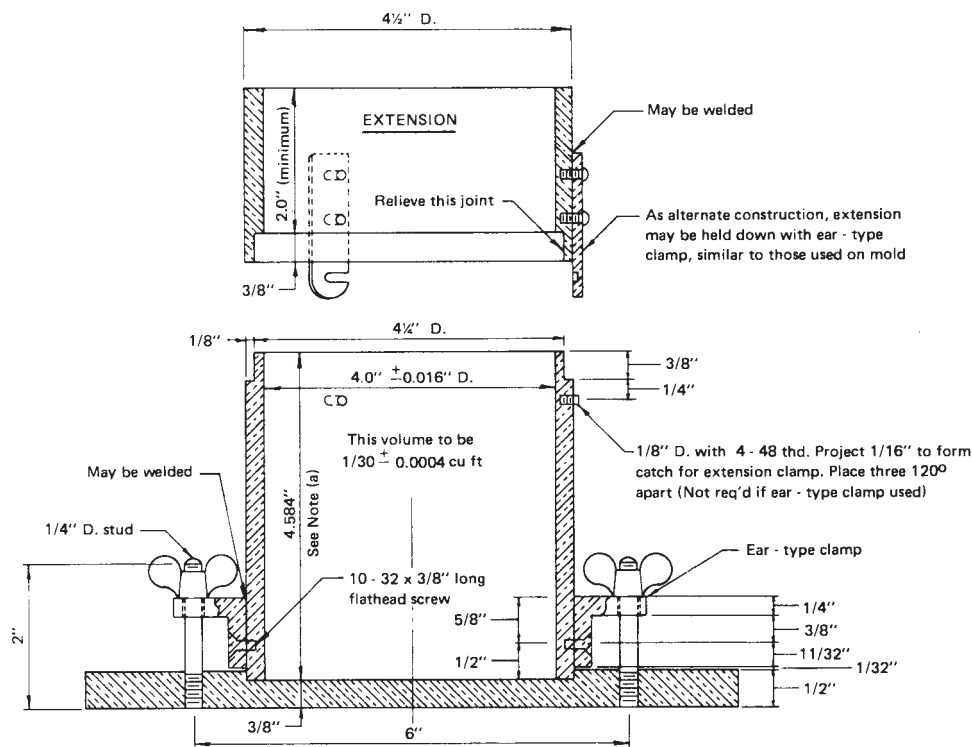

Metric Equivalents

in.	mm
0.016	0.41
0.026	0.66
1/32	0.80
1/16	1.6
1/8	3.2
1/4	6.4
1 1/32	8.7
3/8	9.5
1/2	12.7
5/8	15.9
2	50.8
2 1/2	63.5
4	101.6
4 1/4	108.0
4 1/2	114.3
4.584	116.43
6	152.4
6 1/2	165.1
8	203.2
ft ³	cm
1/30	944
0.004	11
1/13 333	2124
0.0009	25

NOTE 1—The tolerance on the height is governed by the allowable volume and diameter tolerances.

NOTE 2—The methods shown for attaching the extension collar to the mold and the mold to the base plate are recommended. However, others methods are acceptable, providing the attachments are equally as rigid as those shown.

FIG. 1 Cylindrical Mold

4.2 Rammer:

4.2.1 Manual Rammer—A manually operated metal rammer having a 2.0 ± 0.005 -in. (50.80 ± 0.13 -mm) diameter circular face and weighing 5.5 ± 0.02 lb (2.49 ± 0.01 kg). The rammer shall be equipped with a suitable guidesleeve to control the height of drop to a free fall of $12 \pm 1/16$ in. (304.8

± 1.6 mm) above the elevation of the soil-cement. The guidesleeve shall have at least four vent holes not smaller than $3/8$ in. (9.5 mm) spaced 90° apart and located with centers $3/4 \pm 1/16$ in. (19.0 ± 1.6 mm) from each end and shall provide sufficient clearance that freefalls of the rammer shaft and head will not be restricted.

4.2.2 *Mechanical Rammer*—A mechanically operated metal rammer having a 2.0 ± 0.005 -in. (50.80 ± 0.13 -mm) diameter face and a manufactured weight of 5.5 ± 0.02 lb (2.49 ± 0.01 kg). The operating weight of the rammer shall be determined from a calibration in accordance with Methods D 2168. The rammer shall be equipped with a suitable arrangement to control the height of drop to a free-fall of $12.0 \pm \frac{1}{16}$ in. (304.8 ± 1.6 mm) above the elevation of the soil-cement.

4.2.3 *Rammer Face*—Strength and resistance to wetting-and-drying of specimens compacted with the sector face rammer may differ from that of specimens compacted with the circular face rammer. Therefore, the sector face rammer shall not be used unless previous tests on like soil-cement mixtures show that similar resistance to wetting and drying is obtained with the two types of rammers.

4.3 *Sample Extruder*—A jack, lever frame, or other device adapted for the purpose of extruding compacted specimens from the mold. Not required when a split-type mold is used.

4.4 *Balances*—A balance or scale of at least 25-lb (11.3-kg) capacity sensitive to 0.01 lb (0.005 kg) and a balance of at least 1000-g capacity sensitive to 0.1 g.

4.5 *Drying Ovens*—A thermostatically controlled drying oven capable of maintaining temperatures of $230 \pm 9^\circ\text{F}$ ($110 \pm 5^\circ\text{C}$) for drying water content samples, and a thermostatically controlled drying oven capable of maintaining temperatures of $160 \pm 5^\circ\text{F}$ ($71 \pm 3^\circ\text{C}$) for drying compacted soil-cement specimens.

4.6 *Moist Room*—A moist room or suitable covered container capable of maintaining a temperature of $70 \pm 3^\circ\text{F}$ ($21 \pm 1.7^\circ\text{C}$) and a relative humidity of 100 % for 7-day storage of compacted specimens.

4.7 *Water Bath*—Suitable tank for submerging compacted specimens in water at room temperature.

4.8 *Wire Scratch Brush*—A wire scratch brush made of 2 by $\frac{1}{16}$ -in. (50.8 by 1.588-mm) flat No. 26 gage (0.46-mm) wire bristles assembled in 50 groups of 10 bristles each and mounted to form 5 longitudinal rows and 10 transverse rows of bristles on a $7\frac{1}{2}$ by $2\frac{1}{2}$ -in. (190 by 63.5-mm) hardwood block.

4.9 *Straightedge*—A rigid steel straightedge 12 in. (305 mm) in length and having one beveled edge.

4.10 *Sieves*—3-in. (75-mm), $\frac{3}{4}$ -in. (19.0-mm), and No. 4 (4.75-mm) sieves conforming to the requirements of Specification E 11.

4.11 *Mixing Tools*—Miscellaneous tools such as mixing pan, and trowel, or a suitable mechanical device for thoroughly mixing the soil with cement and water.

4.12 *Butcher Knife*—A butcher knife approximately 10 in. (250 mm) in length for trimming the top of the specimens.

4.13 *Scarifier*—A six-pronged ice pick or similar apparatus to remove the smooth compaction plane at the top of the first and second layers of the specimen.

4.14 *Container*—A flat, round pan for moisture absorption by soil-cement mixtures, about 12 in. (305 mm) in diameter and 2 in. (50 mm) deep.

4.15 *Measuring Device*—A measuring device suitable for accurately measuring the heights and diameters of test specimens to the nearest 0.01 in. (0.2 mm).

4.16 *Pans and Carriers*—Suitable pans for handling materials and carriers or trays for handling test specimens.

4.17 *Graduate*—A graduated cylinder of 250-mL capacity for measuring water.

4.18 *Moisture Cans*—Suitable containers for moisture samples.

5. Test Method A—Using Soil Material Passing a No. 4 (4.75-mm) Sieve

5.1 Preparation of Material for Molding Specimens:

5.1.1 Prepare the soil sample in accordance with the procedure described in Test Method A of Test Methods D 558.

5.1.2 Select a sufficient quantity of the soil prepared as described in 5.1.1 to provide two (Note 2) compacted specimens and required moisture samples.

NOTE 2—(Optional) Usually only one specimen (identified as No. 2) is required for routine testing. The other specimen (identified as No. 1) is made for research work and for testing unusual soils.

5.1.3 Add to the soil the required amount of cement conforming to Specification C 150 or Specification C 595. Mix the cement and soil thoroughly to a uniform color.

5.1.4 Add sufficient potable water to raise the soil-cement mixture to optimum water content at the time of compaction and mix thoroughly. When the soil used is a heavy textured clayey material, compact the mixture of soil, cement, and water in the container to a depth of about 2 in. (50 mm) using the rammer described in 4.2 or a similar hand tamper, cover, and allow to stand for not less than 5 min but not more than 10 min to aid dispersion of the moisture and to permit more complete absorption by the soil-cement.

5.1.5 After the absorption period, thoroughly break up the mixture, without reducing the natural size of individual particles, until it will pass a No. 4 (4.75-mm) sieve, as judged by eye, and then remix.

5.2 Molding Specimens:

5.2.1 Form a specimen by immediately compacting the soil-cement mixture in the mold (with the collar attached) and later trimming the specimen in accordance with Test Method A of Test Methods D 558, and in addition scarify the tops of the first and second layers to remove smooth compaction planes before placing and compacting the succeeding layers. This scarification shall form grooves at right angles to each other, approximately $\frac{1}{8}$ in. (3.2 mm) in width and $\frac{1}{8}$ in. (3.2 mm) in depth and approximately $\frac{1}{4}$ in. (6.4 mm) apart.

5.2.2 During compaction, take from the batch a representative sample of the soil-cement mixture, weighing not less than 100 g, weigh immediately, and dry in an oven at $230 \pm 9^\circ\text{F}$ ($110 \pm 5^\circ\text{C}$) for at least 12 h or to constant weight. Calculate the water content as prescribed in Test Methods D 558 to check against design water content.

5.2.3 Weigh the compacted specimen and mold, remove the specimen from the mold, and calculate the oven-dry weight of each specimen in lb/ft^3 (g/cm^3) to check against design density.

5.2.4 Identify the specimen on a metal tag (or other suitable device) as No. 1 (Note 2) together with other needed identification marks and use to obtain data on moisture and volume changes during the test.