



Designation: C 1242 – 03

Standard Guide for Selection, Design, and Installation of Exterior Dimension Stone Anchors and Anchoring Systems¹

This standard is issued under the fixed designation C 1242; the number immediately following the designation indicates the year of original adoption or, in the case of revision, the year of last revision. A number in parentheses indicates the year of last reappraisal. A superscript epsilon (ϵ) indicates an editorial change since the last revision or reappraisal.

INTRODUCTION

Natural building stone is chosen as a building's cladding for its beauty which endures with minimal maintenance. Stone is durable when used properly. Exercising good judgment when selecting the particular stone, determining the quarrying and fabrication techniques, designing the method of attachment, and installing all components correctly maximizes these benefits. A properly executed stone cladding is designed and installed within the capabilities and limitations of the stone and support system to resist all forces that work on them.

This guide presents design principles that require consideration when designing anchorages and evaluating exterior stone to be compatible with its proposed use. It is an overview of current techniques and a review of minimum requirements for sound stone engineering and construction. The guide does not list all possible methods of attachment nor does it provide a step-by-step procedure for stone anchor engineering. Knowledge gained from new engineering designs, testing of applications, and the investigation of existing problems are continually reviewed to update this guide. Comment from users is encouraged.

Good judgment by architects, engineers, and contractors when specifying, designing, engineering, and constructing stone and other work that interfaces stone is necessary to use this guide. Users of this guide should combine known performance characteristics of the stone, the building's structural behavior, and knowledge of materials and construction methods with proven engineering practice.

1. Scope

1.1 This guide covers the categories of anchors and anchoring systems and discusses the design principles to be considered in selecting anchors or systems that will resist gravity loads and applied loads.

1.2 This guide sets forth basic requirements for the design of stone anchorage and provides a practical checklist of those design considerations.

1.3 This guide pertains to:

1.3.1 The anchoring of stone panels directly to the building structure for support,

1.3.2 The anchoring of stone panels to subframes or to curtainwall components after these support systems are attached to the building structure,

1.3.3 The anchoring of stone panels to subframes or to curtainwall components with stone cladding preassembled before these support systems are attached to the building structure, and

1.3.4 The supervision and inspection of fabrication and installation of the above.

1.4 Observe all applicable regulations, specific recommendations of the manufacturers, and standards governing interfacing work.

1.5 The values stated in inch-pound units are to be regarded as the standard. The SI units given in parentheses are for information only.

1.6 *This standard does not purport to address all of the safety concerns, if any, associated with its use. It is the responsibility of the user of this standard to establish appropriate safety and health practices and determine the applicability of regulatory limitations prior to use. (See Tables 1 and 2.)*

¹ This guide is under the jurisdiction of ASTM Committee C18 on Dimension Stone and is the direct responsibility of Subcommittee C18.06 on Anchorage Components and Systems.

Current edition approved April 10, 2003. Published June 2003. Originally approved in 1993. Last previous edition approved in 2002 as C 1242 – 02a.

2. Referenced Documents

2.1 ASTM Standards:

- C 97 Test Methods for Absorption and Bulk Specific Gravity of Dimension Stone²
- C 99 Test Method for Modulus of Rupture of Dimension Stone²
- C 119 Terminology Relating to Dimension Stone²
- C 170 Test Method for Compressive Strength of Dimension Stone²
- C 406 Specification for Roofing Slate²
- C 503 Specification for Marble Dimension Stone (Exterior)²
- C 615 Specification for Granite Dimension Stone²
- C 616 Specification for Quartz-Based Dimension Stone²
- C 629 Specification for Slate Dimension Stone²
- C 880 Test Method for Flexural Strength of Dimensional Stone²
- C 1201 Test Method for Structural Performance of Exterior Dimension Stone Cladding Systems by Uniform Static Air Pressure Difference²
- C 1354 Test Method for Strength of Individual Stone Anchorages in Dimension Stone²
- C 1527 Specification for Travertine Dimension Stone²
- E 632 Practice for Developing Accelerated Tests to Aid Prediction of the Service Life of Building Components and Materials³

3. Terminology

- 3.1 *General Definitions*—For definitions of terms used in this guide, refer to Terminology C 119.
- 3.2 Specific definitions used in the design process are listed in 8.4.

4. Significance and Use

- 4.1 This guide is intended to be used by architects, engineers, and contractors who either design or install exterior stone cladding for architectural structures.
- 4.2 This guide is an industry standard for engineering design considerations, documentation, material considerations,

² Annual Book of ASTM Standards, Vol 04.07.
³ Annual Book of ASTM Standards, Vol

TABLE 1 Dimension Stone Test Methods

Stone Type	ASTM Specification
Calcite ^A	C 503
Dolomite ^A	C 503
Granite	C 615
Limestone ^B	C 568
Marble (exterior) ^B	C 503
Quartz-Based ^B	C 616
Quartzite ^A	C 616
Quartzitic Sandstone ^A	C 616
Sandstone ^A	C 616
Serpentine ^A	C 503
Slate (roof)	C 406
Slate (walls)	C 629
Travertine ^A	C 1527

^A This stone type is a subclassification.
^B This stone type has subclassifications or grades.

TABLE 2 Dimension Stone Test Methods

Measures	ASTM Test Method
liquid porosity and relative density	C 97
combined shear with tensile unit strength from bending	C 99
ultimate crushing unit strength	C 170
primary tensile unit strength from bending	C 880
capacity and deflections of panels assembled with their anchors onto their supporting backup structure	C 1201
individual anchor strength	C 1354
accelerated production of service life	E 632

anchor type applications, and installation workmanship to assist designers and installers to achieve a proper and durable stone cladding.

4.3 Stone and its support systems are part of a building’s skin and shall be compatible with the behavior and performance of other interfacing systems, such as the curtainwall and superstructure frame.

4.3.1 Every stone work application shall comply with applicable building codes.

4.3.2 Provisions of dimension stone handbooks, manuals, and specifications should be reviewed for compatibility with the principles outlined in this guide.

4.3.3 Because stone properties vary, the range and variability of pertinent properties of the stone proposed for use should be determined by testing and statistical methods that are evaluated using sound engineering principles. Use recent test data where applicable. Always reference proven performance of relevant existing structures.

4.3.4 Changes in properties over time shall be considered.

4.3.5 Overall behaviors of all building systems and components including the stone shall be interactively compatible.

5. Installation Standards

5.1 *Documentation*—The basis for standard workmanship shall be established in the design documents issued to describe, regulate, or control the construction. These documents may be issued by the architect, engineer, the design-build authority, the contractor, or others authorized to impose law or code. Examples are as follows:

5.1.1 The architectural drawings and specifications identifying stone type, finish, thickness, sizes, and details and the relationship to other architectural elements and the building structure.

5.1.2 The architectural drawings and specifications identifying the scope of work and the materials required. These may: (1) define the performance criteria to be satisfied, (2) specify the standards of performance to be used in meeting those criteria, (3) provide for adequate performance guarantees for the materials and methods of construction, and (4) prescribe definitive material details and systems to satisfy project requirements. In addition, the specifications shall establish stone fabrication and installation tolerances. The tolerances recommended by stone trade associations could be used as a guide and included in the specification.

5.1.3 Project specifications shall cite the ASTM standard material specification (see 2.1) governing the stone intended for use and identify the classification or grade within that standard specification.

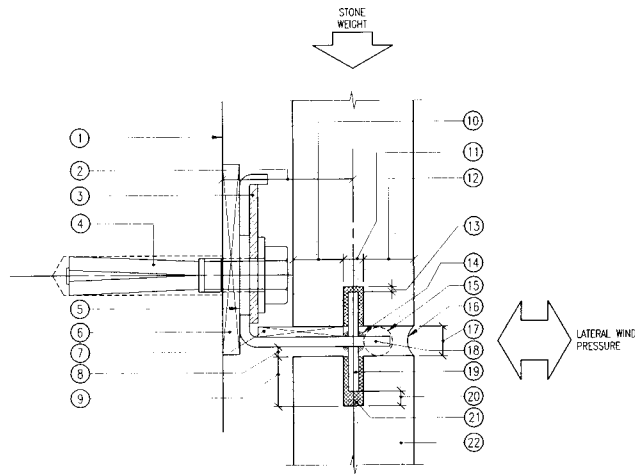

ANCHOR IN HORIZONTAL JOINT CAN SUPPORT GRAVITY AND LATERAL LOADS (FIGURE AS SECTION VIEW)
 ANCHOR IN VERTICAL JOINT CAN SUPPORT ONLY LATERAL LOADS (FIGURE AS PLAN VIEW)

- | | |
|---|--|
| <p>① SUPPORT ANCHORAGE ON COMPATIBLE, STABLE BACKUP.</p> <p>② MINIMIZE DISTANCE TO MINIMIZE ECCENTRIC WEIGHT ON ANCHORAGE AND TO REDUCE FASTENER (PART 4) PULLOUT AND SUPPORT ANGLE (PART 17) DISPLACEMENT. ALLOW FOR FABRICATION, CONSTRUCTION AND INSTALLATION TOLERANCES.</p> <p>③ PREVENT SLIP OF THE CONNECTION AFTER VERTICAL ADJUSTMENT WITH DIAGONALLY SLOTTED WASHER PLATE, WELD WASHER WITH WELD, OR SERRATED ANCHOR AND WASHER. DO NOT RELY ON FRICTION.</p> <p>④ ATTACH ANCHOR WITH FASTENER TO BACKUP.</p> <p>⑤ USE HORIZONTAL SLOT TO ALIGN DOWEL WITH HOLE. VERTICAL SLOT TO ALLOW FOR HEIGHT ADJUSTMENT AND FASTENER PLACEMENT.</p> <p>⑥ PLACE PLASTIC OR METAL ADJUSTMENT BEARING SHIM SLIGHTLY LARGER THAN ANCHOR'S FASTENED FACE. REQUIRED TO SEPARATE AND ADJUST POSITION OF ANCHOR RELATIVE TO FRAMING. MINIMIZE THICKNESS TO MINIMIZE BENDING ON FASTENER (PART 4). THICKNESS AFFECTS FASTENER (PART 4) CAPACITY.</p> <p>⑦ PLACE PLASTIC OR STIFF RUBBER BEARING SHIM FOR LEVELING, SEPARATION, AND TO PREVENT BEARING OF STONE ON DOWEL WELD. ADJUST ANCHOR VERTICALLY WITH PART 3, NOT SHIMS.</p> <p>⑧ MAINTAIN CLEARANCE TO AVOID CONTACT AND WEIGHT TRANSFER (UNLESS DESIGNED TO STACK). ALLOW FOR MOVEMENT, CREEP, EXPANSION, AND FABRICATION, AND INSTALLATION TOLERANCES.</p> <p>⑨ MINIMIZE HOLE DEPTH, INCLUDING VARIANCES PER PART 20, MAINTAIN 3/8 IN. (10mm) ENGAGEMENT OR TESTED MINIMUM. GREATER ENGAGEMENT DOES NOT NECESSARILY INCREASE ANCHOR CAPACITY.</p> <p>⑩ VERIFY INTERIOR EDGE DISTANCE. STONE HERE RESISTS NEGATIVE (OUTWARD AND SUCTION) PRESSURE. MAINTAIN SUFFICIENT WIDTH FROM MINIMUM PANEL THICKNESS.</p> <p>⑪ LOCATE HOLE IN CENTER THIRD OF PANEL THICKNESS. MINIMIZE DIAMETER TO MAXIMIZE EDGE DISTANCE (PARTS 10 AND 12).</p> | <p>⑫ VERIFY EXTERIOR EDGE DISTANCE. STONE HERE RESISTS POSITIVE (INWARD) PRESSURE. KEEP THIS DIMENSION CONSTANT FROM OUTSIDE FACE TO KEEP PANEL FACES ALIGNED.</p> <p>⑬ MAINTAIN CLEARANCE TO AVOID POINT LOADING ON DOWEL END. DIMENSION TO EQUAL OR EXCEED PART 7.</p> <p>⑭ WELD AT FIXED DOWEL. MINIMUM DIAMETER HOLE ONLY FOR CLEARANCE AT DROP (LOOSE) DOWEL.</p> <p>⑮ BOND BREAKER AT ANCHOR AND BACKER ROD BEYOND TO PREVENT THREE SIDED SEALANT BOND.</p> <p>⑯ FILL JOINTS BETWEEN PANELS WITH COMPRESSIBLE GASKET OR SEALANT WITH PROPER PROFILE AND COMPATIBILITY.</p> <p>⑰ SIZE JOINTS TO ALLOW FOR HARDWARE, TOLERANCES, CLEARANCES, APPROPRIATE MOVEMENT AND JOINT FILLER CAPABILITY. ISOLATE DYNAMIC BUILDING MOVEMENTS FROM THIS TYPE OF ANCHOR.</p> <p>⑱ CONNECT DOWEL TO BACKUP WITH METAL LATERAL AND GRAVITY SUPPORT ANGLE (BRAKE-FORMED SHAPED SHOWN). CAN ALSO BE ROLLED OR EXTRUDED SHAPE.</p> <p>⑲ ENGAGE PANEL EDGE WITH A FIXED OR DROP (LOOSE) METAL DOWEL. AVOID DOWEL MISALIGNMENT IN HOLE AND RESULTING PRYING ON STONE PANEL.</p> <p>⑳ MAINTAIN CLEARANCE TO AVOID POINT LOADING ON DOWEL ENDS. DIMENSION TO EQUAL OR EXCEED PART 8. DO NOT ALLOW FLOOR-TO-FLOOR MOVEMENTS TO OCCUR IN THE HOLES.</p> <p>㉑ FILL HOLES WITH COMPRESSIBLE MATERIAL TO PREVENT MOISTURE ACCUMULATION, TO FIX POSITION, AND TO CUSHION BEARING OF DOWEL ON SIDES OF HOLE. WAX, GREASE, WRAP TAPE ON DOWEL OR BED A SLEEVE FOR THE DOWEL TO SLIDE ON WHERE ADHESION IS NOT DESIRED.</p> <p>㉒ DIMENSION STONE CLADDING FACE PANEL.</p> |
|---|--|

FIG. 1 Dowel Anchor

5.1.4 Shop drawings indicating in detail all parts of the work required, including material types, thicknesses, finishes and all other pertinent information dealing with fabrication, anchorage, and installation. The drawings shall show contiguous materials or assemblies which are provided by others in their range of positions according to their specified tolerances.

5.2 Tolerances—Installation tolerances and requirements, once specified, bind the installation contractor, by contract, to perform the work within those specified tolerances. The specification requires the installation contractor to progressively examine the construction to which his work attaches or adjoins, reporting to the prime contractor any condition that may prevent performance within the standard established. Some commonly specified installation tolerances follow:

5.2.1 Variation from plumb of wall surfaces, arises, external corners, joints, and other conspicuous lines should not exceed 1/4 in. (6.4 mm) in any story or in 20 ft (6.1 m) maximum.

5.2.2 Variation in level from grades shown for horizontal joints and other conspicuous lines should not exceed 1/4 in. in 20 ft (6.4 mm in 6.1 m) maximum, nor 3/4 in. in 40 ft (19.1 mm in 12.2 m) or more.

5.2.3 Variation in linear building lines from positions shown on drawings and related portion of wall facing should not exceed 1/2 in. (12.7 mm) in any bay or 20 ft (6.1 m) maximum, nor 3/4 in. in 40 ft (19.1 mm in 12.2 m) or more.

5.2.4 Variation in the face plane of adjacent pieces (lippage) should not exceed one fourth of the width of the joint between the pieces up to but not more than 1/16 in. (1.5 mm) unless panel finish is not smooth or panel size exceeds 20 ft²(1.8 mm²).

5.3 Consultants—Some conditions require professional expertise to determine proper fabrication, installation, engineering, and testing of stone construction.

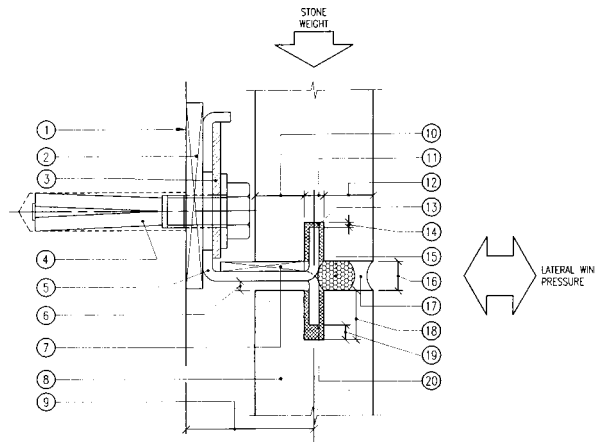

ANCHOR IN HORIZONTAL JOINT CAN SUPPORT GRAVITY AND LATERAL LOADS (FIGURE AS SECTION VIEW)
 ANCHOR IN VERTICAL JOINT CAN SUPPORT ONLY LATERAL LOADS (FIGURE AS PLAN VIEW)

- 1 SUPPORT ANCHORAGE ON COMPATIBLE, STABLE BACKUP.
- 2 PLACE PLASTIC OR METAL ADJUSTMENT BEARING SHIM SLIGHTLY LARGER THAN ANCHOR'S FASTENED FACE. REQUIRED TO SEPARATE DISSIMILAR MATERIALS AND ADJUST TO FRAMING. MINIMIZE THICKNESS TO MINIMIZE BENDING ON FASTENER (PART 4).
- 3 PREVENT SLIP OF THE CONNECTION AFTER VERTICAL ADJUSTMENT WITH DIAGONALLY SLOTTED WASHER PLATE, WELD WASHER WITH WELD, OR SERRATED ANCHOR AND WASHER. DO NOT RELY ON FRICTION.
- 4 ATTACH ANCHOR WITH FASTENER TO BACKUP.
- 5 KERF ANCHOR (BRAKE-FORMED SPLIT-EAR SHAPE SHOWN) OR EXTRUDED SHAPE THAT FITS INTO SAWN KERF. AVOID MISALIGNMENT AND RESULTING PRYING ON KERF FROM INACCURATE FABRICATION OR INSTALLATION. SHOULD NOT BE CONTINUOUS ACROSS PANEL JOINTS. CAPACITY OF CONNECTION IS NOT DIRECTLY PROPORTIONAL TO ANCHOR LENGTH.
- 6 MAINTAIN CLEARANCE TO AVOID CONTACT AND WEIGHT TRANSFER (UNLESS DESIGNED TO STACK). ALLOW FOR MOVEMENT, CREEP, EXPANSION, AND FABRICATION AND INSTALLATION TOLERANCES.
- 7 PLACE PLASTIC OR STIFF RUBBER BEARING SHIM FOR LEVELING, SEPARATION, AND TO PREVENT BEARING OF STONE KERF FIN ON ANCHOR RADIUS. ADJUST ANCHOR VERTICALLY WITH PART 3, NOT SHIMS.
- 8 DIMENSION STONE CLADDING FACE PANEL.
- 9 MINIMIZE DISTANCE TO MINIMIZE ECCENTRIC WEIGHT ON ANCHOR - REDUCES FASTENER (PART 4) PULLOUT AND SUPPORT ANCHOR (PART 5) DISPLACEMENT.
- 10 VERIFY INTERIOR KERF FIN. STONE HERE RESISTS NEGATIVE (OUTWARD OR SUCTION) PRESSURE. MAINTAIN SUFFICIENT WIDTH FROM MINIMUM PANEL THICKNESS.
- 11 LOCATE CONTINUOUS OR INTERMITTENT SAWN KERF IN CENTER THIRD OF THICKNESS. CONTROL WIDTH TO ALLOW TOLERANCE WITH KERF ANCHOR. MINIMIZE WIDTH TO MAXIMIZE EDGE DISTANCES (PARTS 10 AND 12).
- 12 VERIFY EXTERIOR KERF FIN. (3/8 IN. (10mm) MINIMUM) STONE HERE RESISTS POSITIVE (INWARD) PRESSURE. KEEP THIS DIMENSION CONSTANT TO KEEP STONE FACES ALIGNED.
- 13 FILL KERF IN BOTTOM EDGE OF STONE ONLY AT ANCHORS WITH SEALANT TO SET POSITION AND TO CUSHION BEARING.
- 14 MAINTAIN CLEARANCE TO AVOID POINT LOADING AT TOP AND BOTTOM. DIMENSION TO EQUAL OR EXCEED PART 6. DO NOT ALLOW FLOOR-TO-FLOOR MOVEMENTS TO OCCUR IN THE KERF.
- 15 PLACE BACKER ROD OR FOAM TAPE AT PROPER DEPTH TO PREVENT THREE-SIDED SEALANT BOND.
- 16 SIZE JOINTS TO ALLOW FOR HARDWARE, TOLERANCES, CLEARANCES, APPROPRIATE MOVEMENT, AND JOINT FILLER CAPABILITY. ISOLATE DYNAMIC BUILDING MOVEMENTS FROM THIS TYPE OF ANCHOR.
- 17 FILL JOINTS BETWEEN PANELS WITH COMPRESSIBLE GASKET OR SEALANT WITH PROPER PROFILE AND COMPATIBILITY.
- 18 MINIMIZE KERF DEPTH TO MINIMIZE PRYING AND MAXIMIZE CAPACITY. MAINTAIN 3/8 IN. (10mm) MINIMUM OR TESTED MINIMUM ENGAGEMENT.
- 19 MAINTAIN CLEARANCE TO AVOID POINT LOADING AT KERF IN TOP OF STONE. DIMENSION TO EQUAL OR EXCEED PART 6. DO NOT ALLOW DYNAMIC DISPLACEMENTS TO OCCUR IN THE KERF.
- 20 FILL KERF IN TOP EDGE OF STONE CONTINUOUSLY WITH SEALANT TO TOP OF KERF TO PREVENT MOISTURE ACCUMULATION, SET POSITION, AND CUSHION BEARING OF ANCHOR ON SIDES OF KERF.

FIG. 2 Kerf Anchor

5.3.1 In some instances the services of a professional stone cladding designer may be required. Particular conditions where special expertise is suggested to achieve a reliable installation.

5.3.2 In those instances where complex connections or extreme loadings caused by seismic, hurricane, tornado, or installation and handling methods of unknown or questionable performance records are likely to be considered or specified, a stone design specialist may be needed.

5.3.3 Whether such special design skill is required will depend on one or more of the following: knowledge of the performance record of the specified systems and materials; complexity of the cladding system; multiple cladding materials might be used on the same facade; complexity of anchors and connections; unusual or extreme loading condition; unusual frame or structural system may be planned for the project; supporting structure is more flexible than L/600 in any direction; and specific building code requirements exist.

5.4 *Workmanship*—Good construction requires mechanics that have previous successful experience installing similar stonework to do the new work. Less experienced personnel can

only be allowed when they work in a crew continuously with the mechanic who has previous successful experience. Similar work means same type of site fabrication, anchorage, setting method, and support system as the new work.

6. Materials of Construction

6.1 Metals:

6.1.1 Metals used for anchors or anchorage system components are selected according to their use:

6.1.1.1 Metal in contact with stone should be 300 series stainless steel, Types 302 and 304 being the most commonly used. Other metals may be used if properly protected against moisture and galvanic action. Copper and stainless steel wire are used for wire ties.

6.1.1.2 Metal not in direct contact with stone exposed to weather should be stainless steel, galvanized steel, zinc-rich painted or epoxy-coated steel, or aluminum.

6.2 Joint Sealants:

6.2.1 Sealants used in contact with stone can be of the type recommended for the application by the manufacturer, but

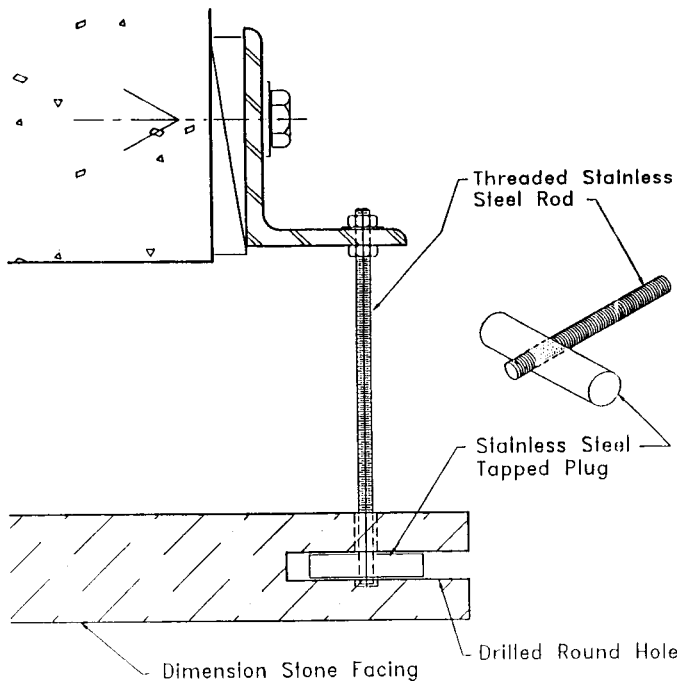

FIG. 3 Rod and Plug Anchor

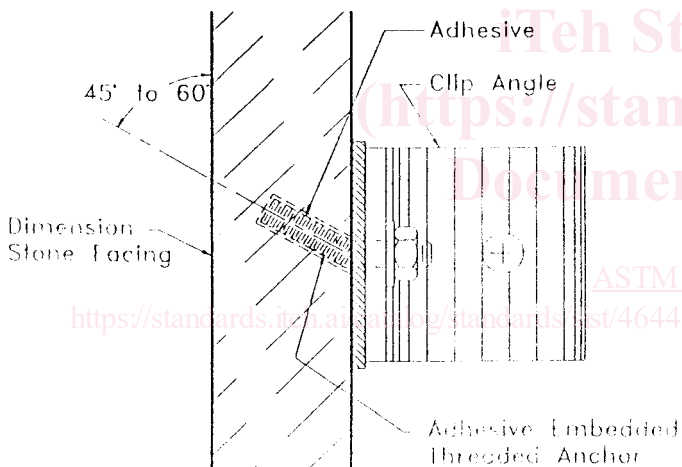

FIG. 4 Adhesive Embedded Threaded Anchor

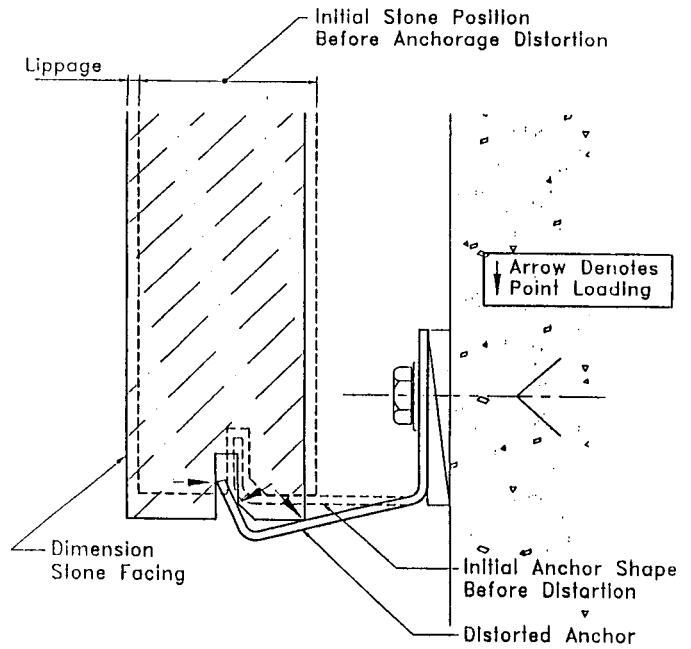

FIG. 5 Point Loading Prevention

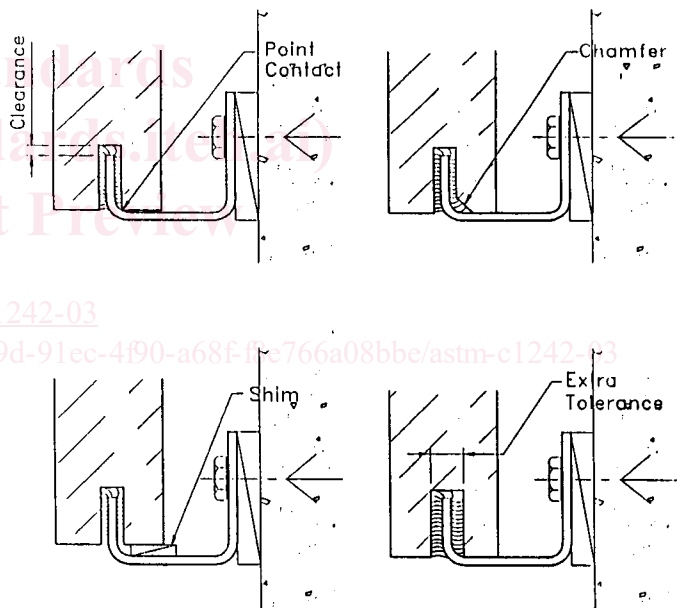

FIG. 5 Point Loading Prevention (continued) (continued)

proper consideration should be given to their ability to satisfy the required properties of tear and peel strength, elasticity, compressibility, durometer, resistance to soiling and fading, and compatibility with any other sealant with which it may come in contact.

6.2.1.1 The manufacturer's recommendation should be followed in respect to temperature range of application, the condition of the substrate and the necessity for a primer.

6.2.1.2 Some sealants may bleed into stone; proper testing is recommended.

6.3 Mortar Materials:

6.3.1 Portland cement, masonry cement, and lime used in preparing cement and lime mortar should be non-staining.

6.3.2 Non-shrink grout should not be used.

6.4 Gasket Materials:

6.4.1 Gasket material selection should be made to satisfy the movement and tolerance requirements. Gaskets are available in

a variety of sections: tubular, lobed, and cellular being the most common. Some gasket materials may bleed into some stones and cause staining. The recommendation of the manufacturer should be followed. Testing may be prudent where information from the manufacturer is not sufficient assurance that bleeding will not occur.

6.4.1.1 Extruded gaskets are usually neoprene or vinyl.

6.4.1.2 Cellular gaskets are usually foamed butyl, polyethylene, or polyurethane.

7. Design Considerations

7.1 Before selecting an anchor system and a support system, certain factors shall be established:

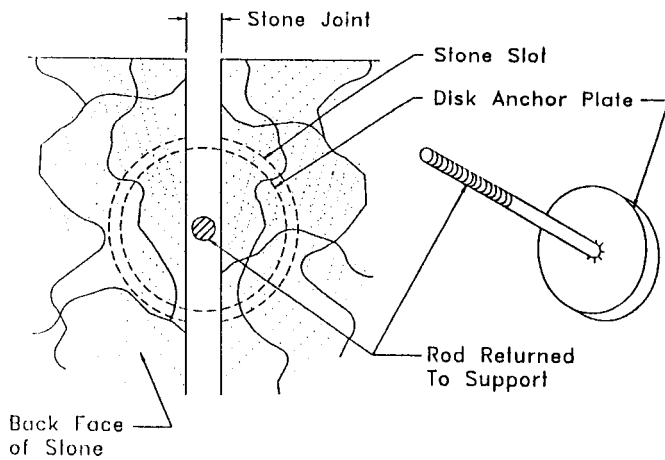

FIG. 6 Disc Anchor

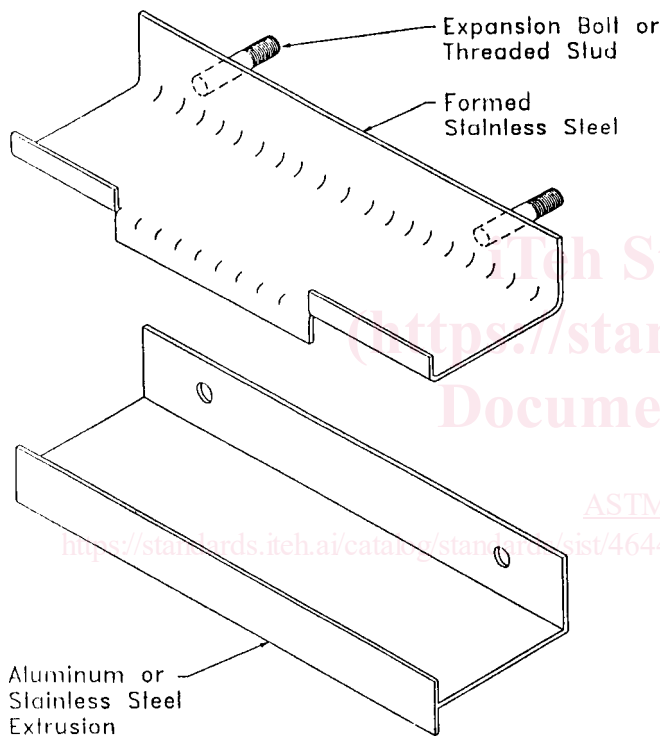

FIG. 7 Combined Anchor

7.1.1 The performance of the stone material under consideration on existing buildings in similar exposures.

7.1.2 The performance of the anchorage and support system under consideration on existing buildings in similar exposures.

7.1.3 The behavior of the anchorage. Anchor and stone together as an assembly are called an anchorage.

7.1.4 The behavior of the facade system. An anchorage with cladding upon a support system is called a facade system.

7.1.5 The physical characteristics of the stone.

7.1.5.1 Some of the material's properties and inconsistencies can be determined by Test Methods C 97, C 99, C 170, and C 880.

7.1.5.2 Other properties, including (but not limited to) bowing tendency, resistance to chemical attack, and weather-related strength reduction and dimensional changes, may be

determined by tests designed to obtain such data. For instance, Test Method C 880 may be modified to produce data revealing the effect of a desired finish. Specific tests may also be designed to obtain the effect of weathering on the selected stone.

7.1.6 Establish design loads and safety factors.

7.1.7 Establish wind and seismic loads.

7.1.8 Anticipate building dimensional changes.

7.1.8.1 Consider wind-load sway, thermally induced change, elastic deformation, and seismic movement; creep and shrinkage should also be considered.

7.1.9 Determine all likely combinations of building and cladding movements.

7.1.10 Accommodate contiguous substructures and components such as window supports, window washing tracks, and backup wall insulation.

7.1.11 Design moisture control through joint design, sealant choice, and internal moisture collection and ventilation systems.

7.1.12 Evaluate potential corrosion due to galvanic and chemical reactions.

7.2 The following general rules are helpful in the design of anchors and connections:

7.2.1 The simplest connections are usually the best.

7.2.2 Make connections with the fewest components.

7.2.3 Use the fewest possible anchor connection types in any particular project.

7.2.4 Provide for adjustability in connections to accommodate tolerances in materials and construction.

7.2.5 Distribute the weight of stone or panel systems on no more than two points of connection where possible.

7.2.6 Make anchor connection locations accessible to the craftsman.

7.2.7 Design connection components and stone sinkages to avoid entrapping moisture.

7.2.8 At friction connections with slotted holes parallel to the direction of load, specify proper bolts, washers, slot size, and bolt installation procedure.

7.3 *Safety Factors*—In order to design an anchoring system, the variabilities of the materials being considered should be known and compensated. This is accomplished through the use of an appropriate safety factor to be applied to the stone, the anchorage, and the backup structure. Appendix X1 discusses in detail the subject of stone safety factors.

8. Design Process

8.1 *System Parts*—There are five main interrelated parts in a stone facade system that are to be considered when designing the cladding system:

8.1.1 *Stone Panels*, cladding the facade,

8.1.2 *Joints*, between the panels,

8.1.3 *Anchor*, connecting the cladding to the supporting backup,

8.1.4 *Subframes*, connecting the anchors to the building structure where the anchor does not attach directly to the building, and

8.1.5 *Primary Building Structure*.

8.2 *Process Purpose*—In this section a recommended process is provided to help designers select and design anchors