



Designation: E338 – 03

# Standard Test Method of Sharp-Notch Tension Testing of High-Strength Sheet Materials<sup>1</sup>

This standard is issued under the fixed designation E338; the number immediately following the designation indicates the year of original adoption or, in the case of revision, the year of last revision. A number in parentheses indicates the year of last reapproval. A superscript epsilon ( $\epsilon$ ) indicates an editorial change since the last revision or reapproval.

*This standard has been approved for use by agencies of the Department of Defense.*

## 1. Scope

1.1 This test method covers the determination of a comparative measure of the resistance of sheet materials to unstable fracture originating from a very sharp stress-concentrator or crack. It relates specifically to fracture under continuously increasing force and excludes conditions of applying force that produce creep or fatigue. The quantity determined is the sharp-notch strength of a specimen of particular dimensions, and this value depends upon these dimensions as well as the characteristics of the material. The sharp-notch strength:yield strength ratio is also determined.

1.2 This test method is restricted to one specimen width which is generally suitable for evaluation of high-strength materials (yield strength-to-density ratio above 18 kgf/mm<sup>2</sup>)/(g/cm<sup>3</sup>) or (700 000 psi/lb-in.<sup>-3</sup>). The test will discriminate differences in resistance to unstable fracture when the sharp-notch strength is less than the tensile yield strength. The discrimination increases as the ratio of the notch strength to the yield strength decreases.

1.3 This test method is restricted to sheet materials not less than 0.64 mm (0.025 in.) and not exceeding 6 mm (0.25 in.) in thickness. Since the notch strength may depend on the sheet thickness, comparison of various material conditions must be based on tests of specimens having the same nominal thickness.

1.4 The sharp-notch strength may depend strongly upon temperature within a certain range depending upon the characteristics of the material. The test method is suitable for tests at any appropriate temperature. However, comparisons of various material conditions must be based on tests conducted at the same temperature.

NOTE 1—Further information on background and need for this type of test is given in the first report by the ASTM Committee on Fracture

<sup>1</sup> This method is under the jurisdiction of ASTM Committee E08 on Fatigue and Fracture and is the direct responsibility of Subcommittee E08.07 on Fracture Mechanics.

Current edition approved May 10, 2003. Published July 2003. Originally approved 1967. Last previous edition approved in 1997 as E338 – 91(97). DOI: 10.1520/E0338-03.

Testing of High-Strength Sheet Materials.<sup>2</sup>

NOTE 2—The values stated in SI (metric) units are to be regarded as the standard.

1.5 *This standard does not purport to address all of the safety concerns, if any, associated with its use. It is the responsibility of the user of this standard to establish appropriate safety and health practices and determine the applicability of regulatory limitations prior to use.*

## 2. Referenced Documents

2.1 ASTM Standards:<sup>3</sup>

E4 Practices for Force Verification of Testing Machines

E8 Test Methods for Tension Testing of Metallic Materials

E602 Test Method for Sharp-Notch Tension Testing with Cylindrical Specimens

E1823 Terminology Relating to Fatigue and Fracture Testing

## 3. Terminology

3.1 Definitions:

3.1.1 *crack strength*,  $\sigma_c$  [FL<sup>-2</sup> ]—the maximum value of the nominal (net-section) stress that a cracked specimen is capable of sustaining.

3.1.1.1 *Discussion*—See definition of **nominal (net-section) stress** in Terminology E1823.

3.1.1.2 *Discussion*—Crack strength is calculated on the basis of the maximum force and the original minimum cross-sectional area (net cross section or ligament). Thus, it takes into account the original size of the crack, but ignores any crack extension that may occur during the test.

3.1.1.3 *Discussion*—Crack strength is analogous to the ultimate tensile strength, as it is based on the ratio of the maximum load to the minimum cross-sectional area of the specimen at the start of the test.

<sup>2</sup> “Fracture Testing of High-Strength Sheet Materials,” *ASTM Bulletin*, ASTBA, No. 243, 1960, pp. 29–40; *ibid.*, No. 244, 1960, pp. 18–28.

<sup>3</sup> For referenced ASTM standards, visit the ASTM website, www.astm.org, or contact ASTM Customer Service at service@astm.org. For *Annual Book of ASTM Standards* volume information, refer to the standard’s Document Summary page on the ASTM website.

3.1.2 *sharp-notch strength*,  $\sigma_s$  [ $\text{FL}^{-2}$  ]—the maximum nominal (net-section) stress that a sharply notched specimen is capable of sustaining.

3.1.2.1 *Discussion*—See definition of **nominal (net-section) stress** in Terminology E1823.

3.1.2.2 *Discussion*—Values of sharp-notch strength may depend on notch and specimen configuration as these affect the net cross section and the elastic stress concentration.

3.1.2.3 *Discussion*—The tension specimens used in Test Method E602 and this test method have notch root radii that approach the limit of machining capability. For these specimens, the radius is believed to be small enough that any smaller radius that is obtainable by standard machining methods would not produce changes, in notch strength, that are significant from an engineering viewpoint.

3.1.2.4 *Discussion*—In these test methods, the notch root radii are very small (approaching the limit for machining capability), and values of sharp-notch strength may depend on notch root radius. See definition of **notch tensile strength** in Terminology E1823.

#### 4. Significance and Use

4.1 The test method provides a comparative measure of the resistance of sheet materials to unstable fracture originating from the presence of cracks or crack-like stress concentrators. It is not intended to provide an absolute measure of resistance to crack propagation which might be used in calculations of the strength of structures. However, it can serve the following purposes:

4.1.1 In research and development of materials, to study the effects of the variables of composition, processing, heat-treatment, etc.;

4.1.2 In service evaluation, to compare the relative crack-propagation resistance of a number of materials which are otherwise equally suitable for an application, or to eliminate materials when an arbitrary minimum acceptable sharp-notch strength can be established on the basis of service performance correlation, or some other adequate basis;

4.1.3 For specifications of acceptance and manufacturing quality control when there is a sound basis for establishing a minimum acceptable sharp-notch strength. Detailed discussion of the basis for setting a minimum in a particular case is beyond the scope of this method.

4.2 The sharp-notch strength may decrease rapidly through a narrow range of decreasing temperature. This temperature range and the rate of decrease depend on the material and its thickness. The temperature of the specimen during each test shall therefore be controlled and recorded. Tests shall be conducted throughout the range of expected service temperatures to ascertain the relation between notch strength and temperature. Care shall be taken that the lowest and highest anticipated service temperatures are included.

4.3 Limited results suggest that the sharp-notch strengths of stable high-strength steels are not appreciably sensitive to rate of loading within the range of loading rates normally used in conventional tension tests. Where very low or high rates of loading are expected in service, the effect of loading rate should be investigated using special procedures that are beyond the scope of this method.

4.4 The precision of sharp-notch strength measurement should be equivalent to that of the ordinary tensile strength of a sheet specimen since both depend upon measurements of force and of dimensions of comparable magnitude. However, the sharp-notch strength is more sensitive to local flaws than the tensile strength and normally shows more scatter. The influence of this scatter should be reduced by testing duplicate specimens and averaging the results.

#### 5. Apparatus

5.1 The test shall be conducted with a tension testing machine that conforms to the requirements of Practices E4.

5.2 The devices for transmitting force to the specimen shall be such that the major axis of the specimen coincides with the force axis. A satisfactory arrangement incorporates clevises carrying hardened pins which pass through holes in the ends of the specimen, the diameter of the pins being only slightly smaller than that of the holes. Spacing washers of the necessary thickness shall be used to center the specimen in the clevises. A typical arrangement is shown in Fig. 1.

5.3 *Temperature Control*—For the tests at other than room temperature, any suitable means may be used to heat or cool the specimen and to maintain a uniform temperature over the region that includes the notch or crack. The ability of the equipment to provide a region of uniform temperature shall be established by measurements of the temperature at positions on both faces of a specimen as shown in Fig. 2. The temperature surveys shall be conducted either at each temperature level at which tests are to be made, or at a series of temperature levels at intervals of 30°C (50°F) over the range of test temperatures. The test temperature shall be held within  $\pm 1\frac{1}{2}$  °C ( $\pm 2\frac{1}{2}$  °F) during the course of the test. At the test temperature the difference between the indicated temperatures at any two of the four thermocouple positions shall not exceed 3°C (5°F).

NOTE 3—A convenient means of heating or cooling flat specimens consists of a pair of flat copper or brass plates which contact the surfaces of the specimen. The plates are fitted with heating or cooling devices

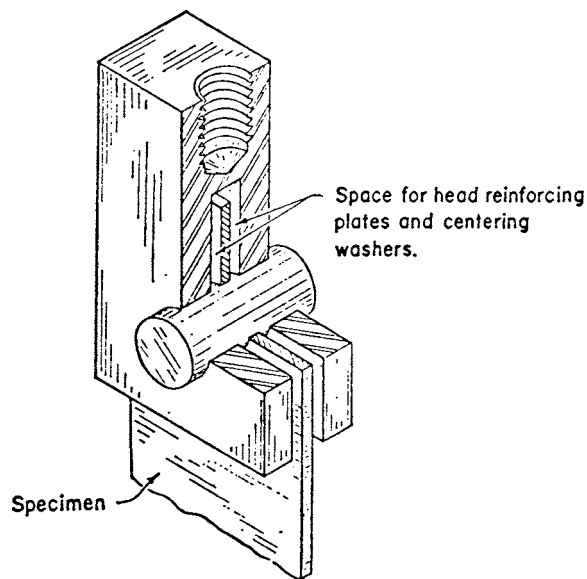
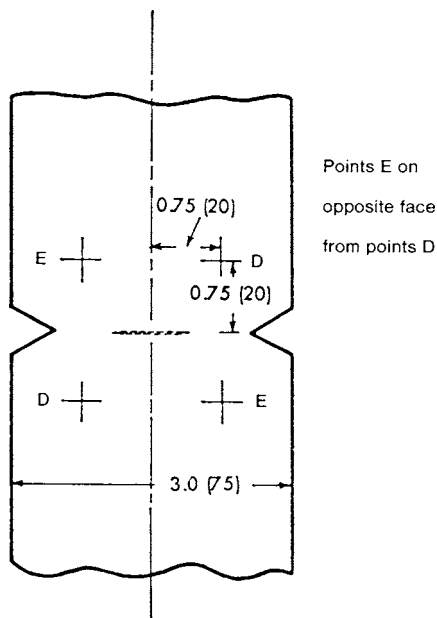

FIG. 1 Specimen Loading Clevis with Hardened Pin



NOTE 1—Dimensions in inches with millimetre dimensions in parentheses.

FIG. 2 Positions of Thermocouple Junctions for Temperature Surveys

designed to maintain uniformity of temperature of the contact surfaces. Thermocouples may be permanently incorporated with their junctions at the contact surfaces. Such devices have been found convenient and reliable for temperatures from that of liquid nitrogen to at least 330°C (600°F).<sup>4</sup> The use of liquid baths for heating specimens shall be avoided unless it can be established that the liquid has no effect on the sharp-notch strength of the material.

5.4 *Temperature Measurement*—The temperature of the specimen during any test at other than room temperature shall be measured at one, or preferably more than one, of the positions shown in Fig. 2. The junctions of the thermocouples shall be in good thermal contact with the specimen. The thermocouples and measuring instruments shall be calibrated and shall not exceed and the difference between the measured temperatures at different positions shall not exceed 3°C (5°F).

## 6. Test Specimens

6.1 Suggested designs for a standard 75-mm (3-in.) wide machined sharp edge-notch test specimen, DE(T), and a fatigue center-crack specimen, M(T), are shown in Fig. 3 and Fig. 4. The dimensions of the notched or cracked regions shall be as indicated and pin loading shall be used. It will be noted that the length of the standard specimen is specified as 300 mm (12 in.) with the provision that, where unavoidable due to material limitations, a substandard length 200 mm, (8 in.) specimen may be used. However, for identical test conditions on the same material the 8-in. specimen will give a different strength value than the standard specimen. For this reason comparisons of various material conditions must be based on tests conducted with the same length specimen. Specimens with parallel sides are shown, and these will fracture in the notched section

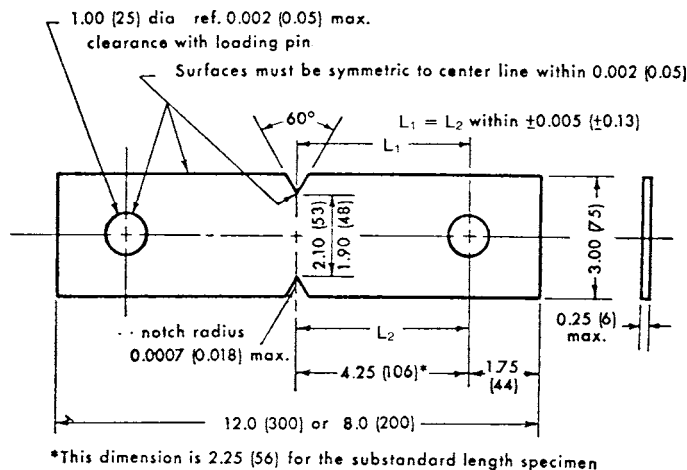

NOTE 1—Dimensions in inches with millimetre dimensions in parentheses.

FIG. 3 Machined Sharp Edge-Notch Specimen, DE(T)

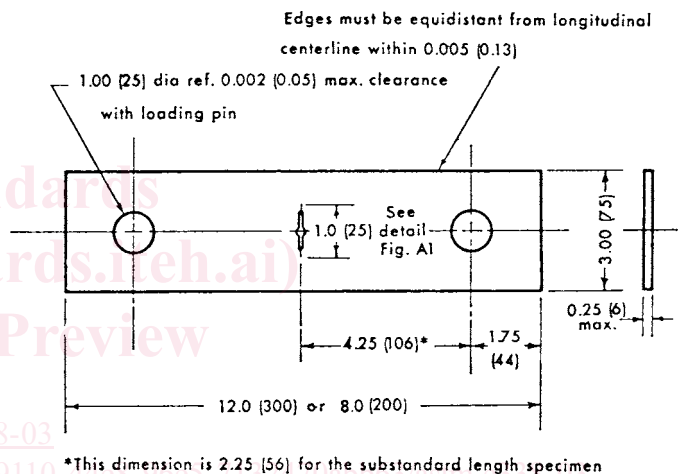

NOTE 1—Dimensions in inches with millimetre dimensions in parentheses.

FIG. 4 Fatigue Center-Crack Specimen M(T)

for the great majority of materials. However, for exceptionally tough conditions where the notch strength exceeds the yield strength, fracture may occur at the pin hole unless suitable head reinforcing plates are provided. A suggested design for such plates is shown in Fig. 5. One plate is used on each side of the specimen heads, and forces are transmitted to the plates by three hardened 6-mm (1/4-in.) diameter pins having a length that will permit them to enter the slot in the loading clevises (see Fig. 1). If the plates are 3 mm (1/8 in.) thick and made of a material having a 1380-MPa (200 000-psi) minimum yield strength, they may be used in any test covered by this method.

6.2 The sharpness of the machined notches is a critical feature of the sharp edge-notched specimen, DE(T), of Fig. 3 and special care is required to prepare them.<sup>5</sup> Finish machining of the notch may be completed either before or after final heat

<sup>4</sup> Srawley, J. E., and Beachem, C. D., *NRL Report 5127*, NRLRA, April 9, 1958.

<sup>5</sup> March, J. L., Ruprecht, W. J., and Reed, George, "Machining of Notched Tension Test Specimens," *ASTM Bulletin*, ASTBA, No. 244, 1960, pp. 52-55.