



Designation: A 343/A 343M – 03

# Standard Test Method for Alternating-Current Magnetic Properties of Materials at Power Frequencies Using Wattmeter-Ammeter-Voltmeter Method and 25-cm Epstein Test Frame<sup>1</sup>

This standard is issued under the fixed designation A 343/A 343M; the number immediately following the designation indicates the year of original adoption or, in the case of revision, the year of last revision. A number in parentheses indicates the year of last reappraisal. A superscript epsilon ( $\epsilon$ ) indicates an editorial change since the last revision or reappraisal.

## 1. Scope

1.1 This test method covers tests for the magnetic properties of basic flat-rolled magnetic materials at power frequencies (25 to 400 Hz) using a 25-cm Epstein test frame and the 25-cm double-lap-jointed core. It covers the determination of core loss, rms exciting power, rms and peak exciting current, and several types of ac permeability and related properties of flat-rolled magnetic materials under ac magnetization.

1.2 This test method shall be used in conjunction with Practice A 34/A 34M.

1.3 This test method<sup>2</sup> provides a test for core loss and exciting current at moderate and high magnetic flux densities up to 15 kG [1.5 T] on nonoriented electrical steels and up to 18 kG [1.8 T] on grain-oriented electrical steels.

1.4 The frequency range of this test method is normally that of the commercial power frequencies 50 to 60 Hz. With proper instrumentation, it is also acceptable for measurements at other frequencies from 25 to 400 Hz.

1.5 This test method also provides procedures for calculating ac impedance permeability from measured values of rms exciting current and for ac peak permeability from measured peak values of total exciting currents at magnetic field strengths up to about 150 Oe [12 000 A/m].

1.6 Explanation of symbols and abbreviated definitions appear in the text of this test method. The official symbols and definitions are listed in Terminology A 340.

1.7 The values and equations stated in either customary (cgs-emu and inch-pound) or SI units are to be regarded separately as standard. Within this standard, SI units are shown in brackets except in the sections concerning calculations where there are separate sections for the respective unit systems. The values stated in each system may not be exact equivalents; therefore, each system shall be used independently

of the other. Combining values from the two systems may result in nonconformance with this standard.

1.8 *This standard does not purport to address all of the safety concerns, if any, associated with its use. It is the responsibility of the user of this standard to establish appropriate safety and health practices and determine the applicability of regulatory limitations prior to use.*

## 2. Referenced Documents

2.1 *ASTM Standards:*

A 34/A 34M Practice for Sampling and Procurement Testing of Magnetic Materials<sup>3</sup>

A 340 Terminology of Symbols and Definitions Relating to Magnetic Testing<sup>3</sup>

A 677/A 677M Specification for Nonoriented Electrical Steel Fully Processed Types<sup>3</sup>

A 683/A 683M Specification for Nonoriented Electrical Steel, Semiprocessed Types<sup>3</sup>

A 876/A 876M Specification for Flat-Rolled, Grain-Oriented, Silicon-Iron, Electrical Steel, Fully Processed Types<sup>3</sup>

A 889/A 889M Test Method for Alternating-Current Magnetic Properties of Materials at Low Inductions Using the Wattmeter-Varmeter-Ammeter-Voltmeter Method and 25-cm (250-mm) Epstein Frame<sup>3</sup>

E 177 Practice for Use of the Terms Precision and Bias in ASTM Test Methods<sup>4</sup>

E 691 Practice for Conducting an Interlaboratory Study to Determine the Precision of a Test Method<sup>4</sup>

E 1338 Guide for the Identification of Metals and Alloys In Computerized Material Property Databases<sup>5</sup>

## 3. Significance and Use

3.1 This test method is a fundamental method for evaluating the magnetic performance of flat-rolled magnetic materials in either as-sheared or stress-relief annealed condition.

3.2 This test method is suitable for design, specification acceptance, service evaluation, and research and development.

<sup>1</sup> This test method is under the jurisdiction of ASTM Committee A06 on Magnetic Properties and is the direct responsibility of Subcommittee A6.01 on Test Methods.

Current edition approved June 10, 2003. Published July 2003. Originally approved in 1949. Last previous edition approved in 1997 as A 343 – 97.

<sup>2</sup> See Burgwin, S. L., "Measurement of Core Loss and A-C Permeability with the 25-cm Epstein Frame," *Proceedings*, American Society for Testing and Materials, ASTEA Vol 41, 1941, p. 779.

<sup>3</sup> *Annual Book of ASTM Standards*, Vol 03.04.

<sup>4</sup> *Annual Book of ASTM Standards*, Vol 14.02.

<sup>5</sup> *Annual Book of ASTM Standards*, Vol 02.05..

4. Test Specimens

4.1 The specimens for this test shall be selected and prepared for testing in accordance with provisions of Practice A 34/A 34M and as directed in Appendix of this test method.

5. Basic Circuit

5.1 Fig. 1 shows the essential apparatus and basic circuit connections for this test method. Terminals 1 and 2 are connected to a source of adjustable ac voltage of sinusoidal waveform and sufficient power rating to energize the primary circuit without appreciable voltage drop in the source impedance. All primary circuit switches and all primary wiring should be capable of carrying much higher currents than are normally encountered to limit primary circuit resistance to values that will not cause appreciable distortion of the flux waveform in the specimen when relatively nonsinusoidal currents are drawn. The ac source may be an electronic amplifier which has a sine-wave oscillator connected to its input and may include the necessary circuitry to maintain a sinusoidal flux waveform by using negative feedback of the induced secondary voltage. In this case, higher primary resistance can be tolerated since this system will maintain sinusoidal flux at much higher primary resistance. Although the current drain in the secondary is quite small, especially when using modern high-input impedance instrumentation, the switches and wiring should be selected to minimize the lead resistance so that the voltage available at the terminals of the instruments is imperceptibly lower than the voltage at the secondary terminals of the Epstein test frame.

6. Apparatus

6.1 The apparatus shall consist of as many of the following component parts as are required to perform the desired measurement functions:

6.2 Epstein Test Frame:

6.2.1 The test frame shall consist of four solenoids (each having two windings) surrounding the four sides of the square magnetic circuit, and a mutual inductor to compensate for air flux within the solenoids. The solenoids shall be wound on nonmagnetic, nonconducting forms of rectangular cross section appropriate to the specimen mass to be used. The solenoids shall be mounted so as to be accurately in the same horizontal plane, and with the center line of solenoids on opposite sides of the square,  $250 \pm 0.3$  mm apart. The compensating mutual inductor may be located in the center of the space enclosed by the four solenoids if the axis of the inductor is made to be perpendicular to the plane of the solenoid windings.

6.2.2 The inner or potential winding on each solenoid shall consist of one fourth of the total number of secondary turns evenly wound in one layer over a winding length of 191 mm or longer of each solenoid. The potential windings of the four solenoids shall be connected in series so their voltages will add. The outer or magnetizing winding likewise shall consist of one fourth of the total number of primary turns evenly wound over the winding length of each solenoid. These individual solenoid windings, too, shall be connected in series so their magnetic field strengths will add. The primary winding may comprise up to three layers using two or more wires in parallel.

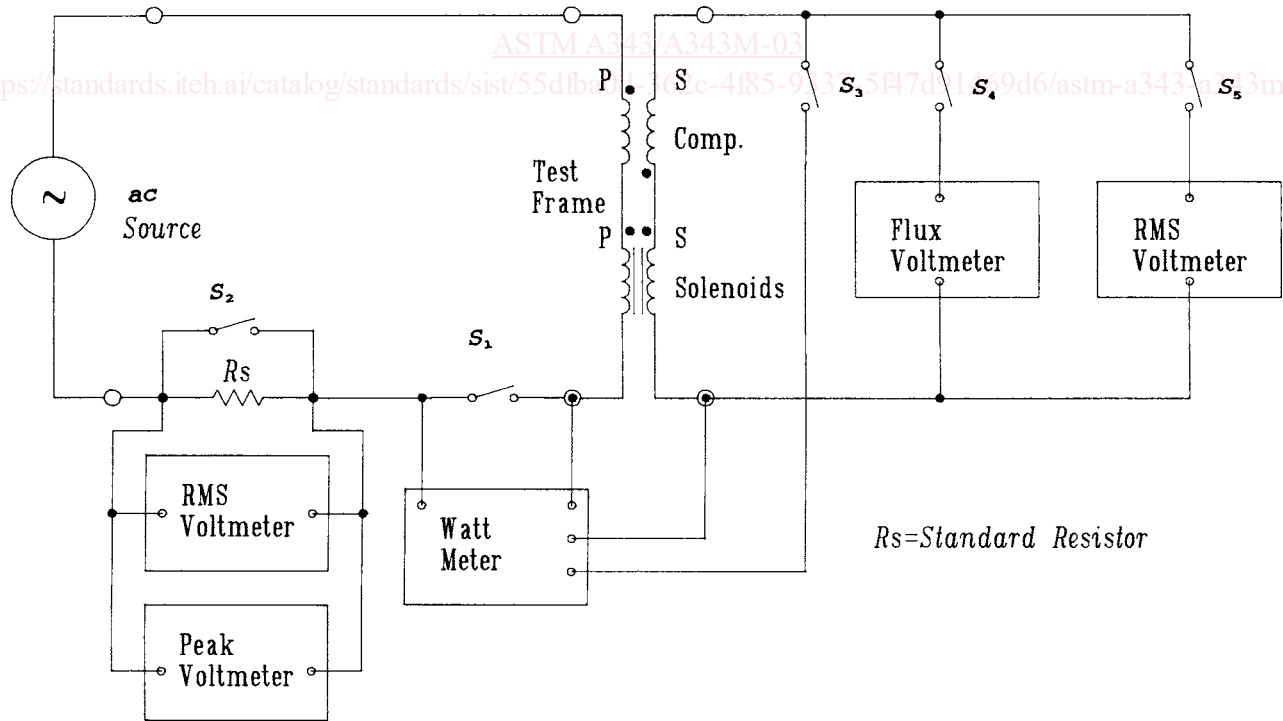

FIG. 1 Basic Circuit for Wattmeter-Ammeter-Voltmeter Method

6.2.3 Primary and secondary turns shall be wound in the same direction, with the starting end of each winding being at the same corner junction of one of the four solenoids. This enables the potential between adjacent primary and secondary turns to be a minimum throughout the length of the winding, thereby reducing errors as a result of electrostatic phenomena.

6.2.4 The solenoid windings on the test frame may be any number of turns suited to the instrumentation, mass of specimen, and test frequency. Windings with a total of 700 turns are recommended for tests in the frequency range of 25 through 400 Hz.

6.2.5 The mutual inductance of the air-flux compensating inductor shall be adjusted to be the same as that between the test-frame windings to within one turn of the compensator secondary. Its windings shall be connected in series with the corresponding test-frame windings so that the voltage induced in the secondary winding of the inductor by the primary current will completely oppose or cancel the total voltage induced in the secondary winding of the test frame when no sample is in place in the solenoids. Specifications for the approximate turns and construction details of the compensating mutual inductor for the standard test frame are given in Table A1.1 of Annex A1.

6.3 *Flux Voltmeter,  $V_f$* —A full-wave true-average, voltmeter, with scale reading in average volts times  $\sqrt{2} \pi/4$  so that its indications will be identical with those of a true rms voltmeter on a pure sinusoidal voltage, shall be provided for evaluating the peak value of the test magnetic flux density. To produce the estimated precision of test under this test method, the full-scale meter errors shall not exceed 0.25 % (Note 1). Meters of 0.5 % of more error may be used at reduced accuracy. Either digital or analog flux voltmeters are permitted. The normally high-input impedance of digital flux voltmeters is desirable to minimize loading effects and to reduce the magnitude of instrument loss compensations. The input resistance of an analog flux voltmeter shall not be less than 1000  $\Omega/V$  of full-scale indication. A resistive voltage divider, a standard-ratio transformer, or other variable scaling device may be used to cause the flux voltmeter to indicate directly in units of magnetic flux density if the combination of basic instrument and scaling device conforms to the specifications stated above.

NOTE 1—Inaccuracies in setting the test voltage produce errors approximately two times as large in the specific core loss. Voltage scales should be such that the instrument is not used at less than half scale. Care should also be taken to avoid errors caused by temperature and frequency effects in the instrument.

6.3.1 If used with a mutual inductor as a peak ammeter at magnetic flux densities well above the knee of the magnetization curve, the flux voltmeter must be capable of accurately measuring the extremely nonsinusoidal (peaked) voltage that is induced in the secondary winding of the mutual inductor. Additionally, if so used, an analog flux voltmeter should have a minimum input resistance of 5000  $\Omega/V$  of full-scale indication.

6.4 *RMS Voltmeter,  $V_{rms}$* —A true rms-indicating voltmeter shall be provided for evaluating the form factor of the voltage induced in the secondary winding of the test fixture and for

evaluating the instrument losses. The accuracy of the rms voltmeter shall be the same as that specified for the flux voltmeter. Either digital or analog rms voltmeters are permitted. The normally high-input impedance of digital rms voltmeters is desirable to minimize loading effects and to reduce the magnitude of instrument loss compensations. The input resistance of an analog rms voltmeter shall not be less than 5000  $\Omega/V$  of full-scale indication.

6.5 *Wattmeter,  $W$* —The full-scale accuracy of the wattmeter must not be poorer than 0.25 % at the frequency of test and at unity power factor. The power factor encountered by a wattmeter during a core loss test on a specimen is always less than unity and, at magnetic flux densities far above the knee of the magnetization curve, approaches zero. The wattmeter must maintain adequate accuracy (1.0 % of reading) even at the most severe (lowest) power factor that is presented to it. Variable scaling devices may be used to cause the wattmeter to indicate directly in units of specific core loss if the combination of basic instrument and scaling devices conforms to the specifications stated here.

6.5.1 *Electronic Digital Wattmeter*—Electronic digital wattmeters have been developed that have proven satisfactory for use under the provisions of this test method. Usage of a suitable electronic digital wattmeter is permitted as an alternative to an electrodynamic wattmeter in this test method. An electronic digital wattmeter oftentimes is preferred in this test method because of its digital readout and its capability for direct interfacing with electronic data acquisition systems.

6.5.1.1 The voltage input circuitry of the electronic digital wattmeter must have an input impedance sufficiently high that connection of the circuitry, during testing, to the secondary winding of the test fixture does not change the terminal voltage of the secondary by more than 0.05 %. In addition, the voltage input circuitry must be capable of accepting the maximum peak voltage that is induced in the secondary winding during testing.

6.5.1.2 The current input circuitry of the electronic digital wattmeter must have an input impedance of no more than 1  $\Omega$ . Preferably the input impedance should be no more than 0.1  $\Omega$  if the flux waveform distortion otherwise tends to be excessive. In addition, the current input circuitry must be capable of accepting the maximum rms current and the maximum peak current drawn by the primary winding of the test fixture when core loss tests are being performed. In particular, since the primary current will be very nonsinusoidal (peaked) if core-loss tests are performed on a specimen at magnetic flux densities above the knee of the magnetization curve, the crest factor capability of the current input circuitry should be three or more.

6.5.2 *Electrodynamometer Wattmeter*—A reflecting-type dynamometer is recommended among this class of instruments, but, if the specimen mass is sufficiently large, a direct-indicating electrodynamic wattmeter of the highest available sensitivity and lowest power-factor capability may be used.

6.5.2.1 The sensitivity of the electrodynamic wattmeter must be such that the connection of the potential circuit of the wattmeter, during testing, to the secondary winding of the test fixture does not change the terminal voltage of the

secondary by more than 0.05 %. Also, the resistance of the potential circuit of the wattmeter must be sufficiently high that the inductive reactance of the potential coil of the wattmeter in combination with the leakage reactance of the secondary circuit of the test fixture does not result in appreciable defect angle errors in the measurements. Should the impedance of this combined reactance at the test frequency exceed 1.0  $\Omega$  per 1000  $\Omega$  of resistance in the wattmeter-potential circuit, the potential circuit must be compensated for this reactance.

6.5.2.2 The impedance of the current coil of the electrodynamic wattmeter should not exceed 1  $\Omega$ . If flux waveform distortion otherwise tends to be excessive, this impedance should be not more than 0.1  $\Omega$ . The rated current-carrying capacity of the current coil must be compatible with the maximum rms primary current to be encountered during core-loss testing. Preferably the current-carrying capacity should be at least 10 rms amperes.

6.6 *Devices for RMS Current Measurement*—A means of measuring the rms value of the exciting current must be provided if measurements of exciting power or exciting current are to be made.

6.6.1 *RMS Voltmeter and Standard Resistor*—A true rms-indicating voltmeter may be used to measure the voltage drop across the potential terminals of a standard resistance. The accuracy of the rms voltmeter shall be 1.0 % of full scale or less. Either digital or analog meters are permitted. A high-input-impedance, multirange electronic digital rms voltmeter is desirable for this instrument. The input resistance of an analog meter shall not be less than 5000  $\Omega/v$ . The standard resistor should be a non-inductive resistor with an accuracy rating of 0.1 % or better. This resistor must be capable of handling the full exciting current of the test winding at the maximum test magnetic flux density without destructive heating or more than specified loss of accuracy as a result of self-heating. To avoid intolerable levels of distortion, the value of the resistor should be kept reasonably low. A fixed resistor between 0.1 and 1.0  $\Omega$  is usually appropriate.

6.6.2 *RMS Ammeter*—A true rms-indicating ammeter may be used to measure the exciting current. A nominal accuracy of 1.0 % of full scale or better is required for this instrument. The instrument must have low internal impedance to avoid contributing to the distortion of the flux waveform.

6.7 *Devices for Peak Current Measurement*—A means of measuring the peak value of the exciting current is required if an evaluation of peak permeability is to be made by the peak-current method.

6.7.1 *Peak-to-Peak Voltmeter and Standard Resistor*—The peak current measurement may be made with a voltmeter whose indications are proportional to the peak-to-peak value of the voltage drop across the potential terminals of a standard resistor connected in series with the primary winding of the test fixture. This peak-to-peak reading (or peak reading) voltmeter shall have a nominal full-scale accuracy of 1.0 % or better at the test frequency and shall be able to accommodate voltages with a crest factor of up to 5. The standard resistor should be a non-inductive resistor with an accuracy rating of 0.1 % or better. This resistor must be capable of handling the full exciting current of the test winding at the maximum test

magnetic flux density without destructive heating or more than specified loss of accuracy due to self-heating. To avoid intolerable levels of distortion, the value of the resistor should be kept reasonably low. A fixed resistor between 0.1 and 1.0  $\Omega$  is usually appropriate.

6.7.2 *Air-Core Mutual Inductor and Flux Voltmeter*—An air-core mutual inductor and a flux voltmeter may be used to measure the peak exciting current. Use of this apparatus is based upon the same theoretical considerations that indicate the use of a flux voltmeter on the secondary of the test fixture to measure the peak magnetic flux density; namely, that when a flux voltmeter is connected to a test coil, the flux voltmeter indications are proportional to the peak value of the flux linking the coil. In the case of the air-core mutual inductor, the peak value of the flux will be proportional to the peak value of the current flowing in the primary winding. A mutual inductor used for this purpose must have reasonably low primary impedance so that its insertion will not materially affect the primary circuit conditions and have sufficiently high mutual inductance to provide a satisfactorily high voltage to the flux voltmeter for primary currents corresponding to the desired range in peak magnetic field strength. The secondary impedance of the mutual inductor must be low if any significant current is drawn by a low-impedance flux voltmeter. The addition of the flux voltmeter should not change the mutual inductor secondary terminal voltage by more than 0.25 %. It is important that the mutual inductor be located in the test equipment in such a position that its windings will not be linked by ac leakage flux from other apparatus. Care should be taken to avoid locating it so close to any magnetic material or any conducting material that its calibration and linearity may be affected. Directions for construction and calibration of a mutual inductor for peak-current measurement are given in Annex A1. Even at commercial power frequencies, there can be appreciable error in the measurement of peak exciting current if winding capacitances and inductances and flux voltmeter errors begin to become important at some of the high harmonics frequencies present because of the extremely non-sinusoidal character of the voltage waveform induced in the secondary of the mutual inductor by the nonsinusoidal exciting current waveform.

6.8 *Power Supply*—A precisely controllable source of sinusoidal test voltage of low internal impedance and excellent voltage and frequency stability is mandatory. Voltage stability within 0.1 % and frequency accuracy within 0.1 % should be maintained. Electronic power sources using negative feedback from the secondary winding of the test fixture to reduce flux waveform distortion have been found to perform quite satisfactorily in this test method.

## 7. Procedure

7.1 Before testing, check the specimen strips for length to see that they conform to the desired length to within  $\pm 1/32$  in. [0.8 mm] (Note 2). Also check the specimen to see that no dented, twisted, or distorted strips showing evidence of mechanical abuse have been included and that the strips are of uniform width (Note 3). Strips having readily noticeable shearing burrs also may be unsuitable for testing. Weigh the specimen on a scale or balance capable of determining the

mass within an accuracy of 0.1 %. Record specimen weights of less than 1 kg to at least the nearest 0.5 g and within the nearest 1.0 g for specimens heavier than 1 kg.

NOTE 2—Inaccuracy in shearing the length of Epstein strips is equivalent to a weighing error of the same percentage. Both weight and specimen length inaccuracies cause errors in magnetic flux density measurements, which result in even greater core loss errors.

NOTE 3—The width of strips in the specimen should be checked for uniformity since nonuniform width will result in nonuniform magnetic flux density in the specimen, which may have a significant but unpredictable effect upon testing accuracy.

7.2 Divide the test specimen strips into four groups containing equal numbers of strips, and very closely the same mass, for testing. Insert the strips (always a multiple of four in number) into the test frame solenoids one at a time, starting with one strip in each of two opposite solenoids and then inserting a strip into each of the other two solenoids so that these latter strips completely overlap the former two at the four corners. This completes one layer of strips constituting a complete flux path with four overlapped joints. Build up successive layers in this same fashion until the specimen is completely assembled. With specimens cut half with and half cross grain, arrange all the parallel or “with-grain” strips in two opposite solenoids and all the cross- or transverse-grain strips in the other two opposite solenoids.

7.3 If the specimen strips are reasonably flat and have a reasonable area of contact at the corners, a sufficiently low reluctance is usually obtained without resorting to pressure on the joints. When the joints are unavoidably poor, the use of light pressure on the joints, from the use of nonmagnetic corner weights of about 200 g, is permissible although it may introduce some additional stresses in strain-sensitive materials. With certain types of magnetic material, or for correct evaluation of properties in certain magnetic flux density ranges, it may be necessary that the specimen be given a heat treatment to relieve stresses before testing. Follow the recommendations of the manufacturer of the materials in performing this operation.

7.4 *Demagnetization*—The specimen should be demagnetized before measurements of any magnetic property are made. With the required apparatus connected as shown in Fig. 1 and switches  $S_1$ ,  $S_2$ , and  $S_4$  closed and switches  $S_3$  and  $S_5$  open, accomplish this demagnetization by initially applying a voltage from the power source to the primary circuit that is sufficient to magnetize the specimen to a magnetic flux density above the knee of its magnetization curve (magnetic flux density may be determined from the reading of the flux voltmeter by means of the equations in 8.1 or 9.1), and then decrease the voltage slowly and smoothly (or in small steps) to a very low magnetic flux density. After this demagnetization, test promptly for the desired test points. When multiple test points are required, perform the tests in order of increasing magnetic flux density values.

7.5 *Setting Magnetic Flux Density*—With switches  $S_3$  and  $S_4$  closed and switches  $S_1$ ,  $S_2$ , and  $S_5$  open, increase the voltage of the power supply until the flux voltmeter indicates the value of voltage calculated to give the desired test magnetic flux density in accordance with the equations in 8.1 or 9.1. Because the action of the air-flux compensator causes a voltage equal to

that which would be induced in the secondary winding by the air flux to be subtracted from that induced by the total flux in the secondary, the magnetic flux density calculated from the voltage indicated by the flux voltmeter is the intrinsic induction,  $B_i = (B - \Gamma_m H_p)$ . In most cases the values of intrinsic induction,  $B_i$ , are not sufficiently different from the corresponding values of normal induction,  $B$ , to require that any distinction be made. Where  $\Gamma_m H_p$  is not insignificant compared to  $B_i$ , as it is at very high magnetic flux densities, determine the value of  $B$  by adding to  $B_i$  either the measured value of  $\Gamma_m H_p$  or a nominal value known to be reasonably typical of the class of material being tested.

7.6 *Core Loss*—When the voltage indicated by the flux voltmeter has been adjusted to the desired value, read the wattmeter. Some users, particularly those having wattmeters compensated for their own losses (or burden), will desire to open switch  $S_4$  to eliminate the flux voltmeter burden from the wattmeter indication. Others will likely choose to have  $S_4$  and  $S_5$  closed when measuring the losses, so that all instruments may be read at the same time. In the latter case, the combined resistance load of the flux voltmeter, rms voltmeter, and potential circuit of the wattmeter will constitute the total instrument burden on the wattmeter. Exercise care so that the combined current drain of the instruments does not cause an appreciably large voltage drop in the secondary circuit resistance of the test frame. In such a case, the true magnetic flux density in the specimen may be appreciably higher than is apparent from the voltage measured at the secondary terminals of the test frame. In any event, power as a result of any current drain in the secondary circuit at the time of reading the wattmeter must be known so it can be subtracted from the wattmeter indications to obtain the net watts caused by core loss.

7.7 Obtain the specific core loss of the specimen in watts per unit mass at a specified frequency by dividing the net watts by that portion of the mass of the specimen constituting the active magnetic flux path (which is less than the mean geometric path length) in the specimen. Equations and instructions for computing the active mass of the specimen and the specific core loss are given in 8.2 and 9.2.

7.8 Measure the rms value of the secondary voltage by having both  $S_4$  and  $S_5$  closed and the voltage adjusted to indicate the correct value of flux volts. On truly sinusoidal voltage, both voltmeters will indicate the same voltage showing that the form factor of the induced voltage is  $\sqrt{2} \pi / 4$ . When the voltmeters give different readings, the ratio of the rms value to that indicated by the flux voltmeter reveals the ratio by which the form factor of the induced voltage deviates from the desired value of  $\sqrt{2} \pi / 4$ . Determining the magnetic flux density from the readings of a flux voltmeter assures that the correct value of peak magnetic flux density is achieved in the specimen, and hence that the hysteresis component of the core loss is correct even if the waveform is not strictly sinusoidal. But the eddy-current component of the core loss, being caused by current resulting from a nonsinusoidal voltage induced in the cross section of the strip, will be in error depending on the deviation of the induced voltage from the desired sinusoidal wave shape. This error in the eddy-current

component of loss can be readily corrected by calculations based on the observed form factor and the approximate percentage of eddy-current loss for the grade of material being tested if the correction is reasonably small. The equations involved in determining this correction are given in 8.3 and 9.3.

**7.9 RMS Exciting Current**—Measure the rms exciting current, when required, by having  $S_1$  and  $S_4$  closed;  $S_2$ ,  $S_3$ , and  $S_5$  open; then with the ammeter on a suitable scale range, adjust the voltage to the correct flux voltmeter indication for the desired test magnetic flux density. When the setting of voltage is correct, open  $S_4$  and read the ammeter with no current drain in the secondary circuit. If  $S_4$  is kept closed to monitor the magnetic flux density during the current reading, the current drain of the flux voltmeter will be included in the ammeter indication. If exciting current is to be reported in terms of ampere-turns per unit path length, volt-amperes per unit mass, or permeability from impedance, calculate the values of these parameters from the equations of 8.4 and 9.4.

**7.10 Permeability**—When permeability from peak exciting current is required, determine the peak value of exciting current using the peak-reading voltmeter and standard resistor. Switch  $S_1$  should be closed to protect the wattmeter from the possibility of excessive current. Switches  $S_3$  and  $S_5$  should be open to minimize secondary loading. With switch  $S_2$  open and  $S_5$  closed, adjust the voltage to the correct value for the desired magnetic flux density or the correct value of peak current for the desired magnetic field strength. Equations involved in the determination of peak magnetic field strength using a peak-reading voltmeter are given in 8.6 and 9.6.

**7.11** If the mutual inductor and flux voltmeter are used to determine peak current rather than the standard resistor and peak-reading voltmeter, follow the same procedure as in 7.10. The flux voltmeter used for this purpose must meet the restrictions of 6.7.2. Equations involved in the determination of peak magnetic field strength using a mutual inductor and flux voltmeter are given in 8.6 and 9.6.

## 8. Calculation (Customary Units)

**8.1** Calculate the value of the flux voltage  $E_f$  at the desired test magnetic flux density in the specimen (when corrected for flux due to  $H$  in the material and in the air space encircled by the test winding through the use of the required air-flux compensator) in accordance with the following basic equation discussed in X1.2 of this test method:

$$E_f = \sqrt{2} \pi B_i A N_2 f 10^{-8} \quad (1)$$

where:

- $B_i$  = maximum intrinsic flux density, G;
- $A$  = effective cross-sectional area of the test specimen, cm<sup>2</sup>;
- $N_2$  = number of turns in secondary winding; and
- $f$  = frequency, Hz.

**8.1.1** In the case of Epstein specimens, where the total number of strips is divided into four equal groups comprising the magnetic circuit, the mass of the specimen in each of the four legs of the magnetic circuit becomes  $m/4$ , and the effective cross section,  $A$ , in square centimeters, of each leg is:

$$A = m/4\delta \quad (2)$$

where:

- $m$  = total mass of specimen strips, g;
- $l$  = length of specimen strips, cm (usually 28 or 30.5 cm); and
- $\delta$  = standard assumed density of specimen material (see Practice A 34/A 34M), g/cm<sup>3</sup>.

**8.2 Core Loss**—To obtain the specific core loss of the specimen in watts per unit mass, it is necessary to subtract all secondary circuit power included in the wattmeter indication before dividing by the active mass of the specimen, so that for a specific magnetic flux density and frequency the specific core loss in watts per pound is as follows:

$$P_{c(B,f)} = 453.6 (P_c - E_2^2/R)/m_1 \quad (3)$$

where:

- $P_c$  = core loss indicated by the wattmeter, W;
- $E_2$  = rms value of secondary voltage, V;
- $R$  = parallel resistance of wattmeter potential circuit and all other connected secondary loads,  $\Omega$ ; and
- $m_1$  = active mass, g.

In the 25-cm Epstein frame, it is assumed that 94 cm is the effective magnetic path with specimen strips 28 cm or longer. For the purpose of computing core loss, the active mass of the specimen (less than the total mass) is assumed to be as follows:

$$m_1 = l_1 m / (4l) = 94m / 4l = 23.5m/l \quad (4)$$

where:

- $m$  = total specimen mass in pounds;
- $l_1$  = effective magnetic path length, cm; and
- $l$  = actual strip length, cm.

**8.3 Form Factor Correction**—The percent error in form factor is given by the following equation:

$$F = 100(E_2 - E_f)/E_f \quad (5)$$

assuming (Note 4) that:

$$\text{observed } P_{c(B,f)} = [(\text{corrected } P_{c(B,f)})/100]h + (\text{corrected } P_{c(B,f)})Ke/100,$$

then, the corrected core loss, which shall be computed when  $F$  is greater (Note 5) than  $\pm 1\%$ , is:

$$\text{Corrected } P_{c(B,f)} = (\text{observed } P_{c(B,f)})100/(h + Ke) \quad (6)$$

where:

- $\text{observed } P_{c(B,f)}$  = specific core loss calculated by the equations in 8.2,
- $h$  = percentage hysteresis loss at magnetic flux density  $B$ ,
- $e$  = percentage eddy-current loss at magnetic flux density  $B$ , and
- $K$  =  $(E_2/E_f)^2$ .

Obviously,  $h = 100 - e$  if residual losses are considered negligible. The values of  $h$  and  $e$  in the above equation are not critical when waveform distortion is low. Typical values at 50 or 60 Hz for the common classes of materials, strip thicknesses, and specimen form are shown in Table 1. Values for materials other than those shown may be obtained using core loss separation methods and are a matter of agreement between the producer and the user.