



Standard Specification for Cold Expansion Fittings with PEX Reinforcing Rings for Use with Cross-linked Polyethylene (PEX) Tubing¹

This standard is issued under the fixed designation F 1960; the number immediately following the designation indicates the year of original adoption or, in the case of revision, the year of last revision. A number in parentheses indicates the year of last reapproval. A superscript epsilon (ϵ) indicates an editorial change since the last revision or reapproval.

1. Scope

1.1 This specification covers cold expansion fittings and cross-linked (PEX) reinforcing rings for use with cross-linked polyethylene (PEX) plastic tubing in $\frac{3}{8}$, $\frac{1}{2}$, $\frac{5}{8}$, $\frac{3}{4}$, 1, 1- $\frac{1}{4}$, and 1- $\frac{1}{2}$ in. nominal diameters that meet the requirements of Specifications F 876 and F 877. These fittings are intended for use in 100 psi (690 kPa) cold- and hot-water distribution systems operating at temperatures up to and including 180°F (82°C). The system is comprised of a PEX reinforcing ring and a cold expansion fitting. Included are the requirements for materials, workmanship, dimensions, and markings to be used on the fitting components. The components covered by this specification are intended for use in residential and commercial, hot and cold, potable water distribution systems as well as sealed central heating, including under-floor-heating systems.

1.2 The values stated in inch-pound units are to be regarded as the standard. The values given in parentheses are mathematical conversions to SI units which are provided for information only and are not considered standard.

1.3 *This standard does not purport to address all of the safety concerns, if any, associated with its use. It is the responsibility of the user of this standard to establish appropriate safety and health practices and determine the applicability of regulatory limitations prior to use.*

2. Referenced Documents

2.1 ASTM Standards:

- A 351 Specification for Castings, Austenitic, Austenitic-Ferritic (Duplex), for Pressure-Containing Parts²
- B 16 Specification for Free-Cutting Brass Rod, Bar, and Shapes for Use in Screw Machines³
- B 140/B 140M Specification for Copper-Zinc-Lead (Leaded Red Brass or Hardware Bronze) Rod, Bar, and Shapes³

- B 283 Specification for Copper and Copper-Alloy Die Forging (Hot Pressed)³
- B 584 Specification for Copper Alloy Sand Castings for General Applications³
- D 792 Test Methods for Density and Specific Gravity (Relative Density) of Plastics by Displacement⁴
- D 1505 Test Method for Density of Plastics by the Density-Gradient Technique⁴
- D 1600 Terminology for Abbreviated Terms Relating to Plastics⁴
- D 2122 Test Method for Determining Dimensions of Thermoplastic Pipe and Fittings⁵
- D 2765 Test Methods for Determination of Gel Content and Swell Ratio of a Crosslinked Ethylene Plastics⁶
- D 3045 Practice for Heat Aging of Plastics Without Load⁶
- D 6394 Specification for Sulfone Plastics (SP)^{1,7}
- F 412 Terminology Relating to Plastic Piping Systems⁴
- F 876 Specification for Crosslinked Polyethylene (PEX) Tubing⁵
- F 877 Specification for Crosslinked Polyethylene (PEX) Plastic Hot and Cold-Water Distribution Systems⁵

2.2 Military Standard:

MIL-STD-P46120A Polysulfone GF120⁸

2.3 ANSI Standard:

- B1.20 Pipe Threads General Purpose⁹
- B16.18 Cast Copper Alloy Solder Joint Pressure Fittings
- B16.22 Wrought Copper and Copper Alloy Solder Joint Pressure Fittings

2.4 NSF Standards:

NSF 14 for Plastic Piping Components and Related Materials¹⁰

¹ This specification is under the jurisdiction of ASTM Committee F17 on Plastic Piping Systems and is the direct responsibility of Subcommittee F17.10 on Fittings. Current edition approved April 10, 2003. Published July 2003. Originally approved in 1999. Last previous edition approved in 2002 as F 1960 – 02b.

² Annual Book of ASTM Standards, Vol 01.02.

³ Annual Book of ASTM Standards, Vol 02.01.

⁴ Annual Book of ASTM Standards, Vol 08.01.

⁵ Annual Book of ASTM Standards, Vol 08.04.

⁶ Annual Book of ASTM Standards, Vol 08.02.

⁷ Annual Book of ASTM Standards, Vol 08.03.

⁸ Available from Standardization Documents Order Desk, Bldg. 4 Section D, 700 Robins Ave., Philadelphia PA 19111-5094, Attn: NPODS.

⁹ Available from the American National Standards Institute, 11 West 42nd St., 13th Floor, New York, NY, 10036.

¹⁰ Available from the National Sanitation Foundation (NSF International), PO Box 1468, Ann Arbor, MI, 48106.

NSF 61 for Drinking Water System Components-Health Effects¹⁰

2.5 *Manufacturers' Standardization Society Standards:*
SP 104 Wrought Copper Solder Joint Pressure Fittings¹¹

3. Terminology

3.1 *Definitions*—Definitions are in accordance with Terminology F 412 and abbreviations are in accordance with Terminology D 1600, unless otherwise indicated.

3.1.1 *PEX reinforcing rings*—cross-linked polyethylene rings used to add contraction force around the cold expansion fittings.

4. Classification

4.1 This specification covers one class of cold expansion fittings with PEX reinforcing rings suitable for use with PEX tubing that meets the requirements of Specifications F 876 and F 877.

5. Materials and Manufacture

5.1 Cold expansion fittings shall be made from one of the following materials:

5.1.1 Brass:

5.1.1.1 *Machined Brass*—Machined brass fittings shall be made from material meeting the requirements of Specification B 140 copper alloy UNS C31400 or Specification B 16 copper alloy UNS C36000.

5.1.1.2 *Forged Brass*—Forged brass fittings shall be made from material meeting the requirements of Specification B 283 copper alloy UNS C37700 or UNS C89844.

5.1.1.3 *Sand Casted Brass*—Sand casted brass fittings shall be made from material meeting the requirements of Specification B 584 copper alloy UNS C84400 or other approved material meeting the requirements of Specification B 584.

5.1.2 Sulfone:

5.1.2.1 *20 % Glass-Filled Polysulfone*—Glass-filled polysulfone fittings shall be made from materials meeting the requirements of MIL-STD-P46120A Polysulfone GF120.

5.1.2.2 *Unreinforced Sulfone Plastic (SP)*—The material shall be unreinforced group 01 or 03; class 1; grade 1, 2, or 3 for group 03 or grade 1, 2, 3, 4, 5 or 6 for group 01 as specified in Specification D 6394. Material may also be a blend of two or more of the specified groups.

5.1.2.3 Material must meet all requirements of this specification. the ratio of rework material to total material shall not exceed 25 %.

5.2 Reinforcing rings shall be made from PEX material meeting the performance requirements of 6.1.

5.3 *Stainless Steel*—fittings shall be made from material meeting the requirements of Specification A 351 stainless steel UNS J92800.

6. General Requirements

6.1 The following sections of Specification F 877 constitute a part of this specification.

6.1.1 Requirements,

6.1.2 Test Methods, and

6.1.3 Retest and Rejection.

6.2 In addition, when a section with a title identical to that referenced in 6.1, above, appears in this specification, it contains additional requirements that supplement those appearing in F 877.

6.3 *System Performance Requirements:*

6.3.1 *General*—All performance tests shall be performed on assemblies of fittings, PEX reinforcing rings and PEX tubing. Fittings and reinforcing rings shall meet the material and dimensional requirements of this specification. PEX tubing shall meet the requirements of Specifications F 876 and F 877. Assembly of test specimens shall be in accordance with 10.1. Each assembly shall contain at least two joints. Use separate sets of assemblies for each performance test requirement.

6.3.2 *Dimensions*—Any randomly selected fitting or fittings and PEX reinforcing rings shall be used to determine dimensions. Measurements shall be made in accordance with Test Method D 2122, except determine diameter by making measurements at four locations spaced at approximately 45° apart around the circumference. Inspection and gauging of solder joint ends shall be accordance with ANSI B16.18, ANSI B16.22, or MSS SP-104.

7. Performance Requirements

7.1 *PEX Reinforcing Rings:*

7.1.1 *Density*—When determined in accordance with 11.1, the PEX reinforcing rings shall have a density in the range from 926 to 940 kg/m³.

7.1.2 *Degree of Cross-linking*—When tested in accordance with 11.2, the degree of cross-linking for PEX reinforcing rings shall be within the range from 70 to 89% inclusive.

7.1.3 *Stabilizer Migration Resistance*—When tested in accordance with 11.3, the time t^2 , shall be at least 50% of the time, t^1 .

8. Dimensions

8.1 *Dimensions and Tolerances*—The dimensions and tolerances of fittings and PEX reinforcing rings shall be as shown in Figs. 1 and 2 and Fig. 4 when measured in accordance with 6.3.2.

8.1.1 *Alignment*—The maximum angular variation of any opening shall not exceed 1° off the true centerline axis.

8.1.2 *Fittings with Solder Joint Ends*—Solder joint ends shall be in accordance with ANSI B16.22, ANSI B16.18 or MSS SP-104.

8.1.3 *Tapered Threaded Ends*—Fitting threads shall be right-hand conforming to ANSI B1.20.1. They shall be taper threads (NPT).

9. Workmanship, Finish and Appearance

9.1 The fittings shall be made from compounds that are homogeneous throughout. The sealing surfaces of the insert shall be smooth and free of foreign material. The fitting walls shall be free of cracks, holes, blisters, voids, foreign inclusions, or other defects that are visible to the naked eye and that affect wall integrity.

¹¹ Available from Manufacturers' Standardization Society of the Valve and Fittings Industry 127 Park St. NE Vienna, VA 22180

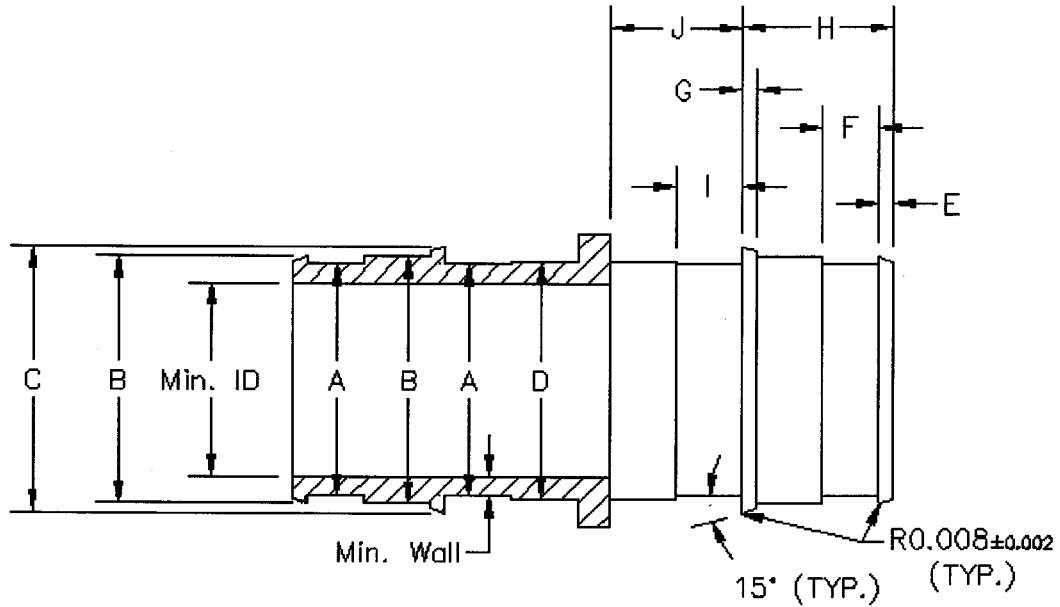

NOTES: BREAK ALL INTERNAL CORNERS 0.005 – 0.015
ALL DIAMETER CONCENTRICITY 0.005 TIR

(https://standards.iteh.ai)
Document Preview

BRASS DIMENSIONS

SIZE	Min. Wall	Min. ID	A	B	C	D	E	F	G	H	I	J
3/8"	0.047	0.260	0.395	0.441	0.480	0.427	0.067	0.128	0.067	0.325	0.127	0.286
			0.375	0.433	0.472	0.407	0.051	0.108	0.051	0.305	0.107	0.266
1/2"	0.057	0.378	0.533	0.579	0.618	0.565	0.067	0.128	0.067	0.404	0.167	0.325
			0.513	0.571	0.610	0.545	0.051	0.108	0.051	0.384	0.147	0.305
5/8"	0.057	0.500	0.655	0.697	0.748	0.683	0.067	0.167	0.067	0.482	0.207	0.404
			0.635	0.689	0.740	0.663	0.051	0.147	0.051	0.462	0.187	0.384
3/4"	0.057	0.595	0.748	0.795	0.874	0.782	0.067	0.207	0.067	0.522	0.246	0.443
			0.728	0.787	0.866	0.762	0.051	0.187	0.051	0.502	0.226	0.423
1"	0.072	0.795	0.985	1.032	1.110	0.998	0.067	0.246	0.067	0.640	0.285	0.561
			0.965	1.024	1.102	0.978	0.051	0.226	0.051	0.620	0.265	0.541
1-1/4"	0.075	0.884	1.071	1.129	1.229	1.098	0.080	0.299	0.080	0.781	0.348	0.684
			1.051	1.121	1.221	1.078	0.064	0.279	0.064	0.761	0.328	0.664
1-1/2"	0.095	1.084	1.324	1.382	1.494	1.349	0.093	0.351	0.093	0.919	0.408	0.805
			1.304	1.374	1.486	1.329	0.077	0.331	0.077	0.899	0.388	0.785

FIG. 1 Brass and Stainless Steel Insert Dimensions and Tolerances

10. Assembly

10.1 *Cold Expansion Joints*—Fittings shall be joined to PEX tubing by the contraction of the tubing and reinforcing

ring over the insert of the cold expansion fitting. Fittings and PEX reinforcing rings shall meet the dimensional and material