Oscillation-type density meters —

Part 1:
Laboratory instruments

Densimètres à oscillations —

Partie 1: Instruments de laboratoire

iTeh STANDARD PREVIEW
(standards.iteh.ai)

ISO 15212-1:1998

<https://standards.iteh.ai/catalog/standards/sist/4efbb1aa-47ab-420e-8ed7-20c5998402b5/iso-15212-1-1998>



Contents	Page
1 Scope	1
2 Normative references	1
3 Definitions	2
4 Principle and functional units	2
4.1 Measuring principle	2
4.2 Functional units	2
5 Density sensor	3
5.1 Sensor material	3
5.2 Sensor design	3
6 Requirements and tests	4
6.1 Oscillation system	4
6.2 Temperature control and measurement	5
6.3 Displays	7
6.4 Auxiliary units and data transfer	7
6.5 Safety requirements	8
6.6 Electromagnetic compatibility	8
7 Adjustment	8
8 Calibration	8
8.1 Density reference liquids	8
8.2 Particular density reference liquids	9
8.3 Calibration requirements	9
8.4 Calibration procedure	9

ITeh STANDARD PREVIEW
(standards.iteh.ai)

ISO 15212-1:1998
<http://standards.iteh.ai/catalog/standards/sist/4c6bb1ea-47ab-420a-8ad7-20c5998402b5/iso-15212-1-1998>

© ISO 1998

All rights reserved. Unless otherwise specified, no part of this publication may be reproduced or utilized in any form or by any means, electronic or mechanical, including photocopying and microfilm, without permission in writing from the publisher.

International Organization for Standardization
Case postale 56 • CH-1211 Genève 20 • Switzerland
Internet iso@iso.ch

Printed in Switzerland

9 Density meter accuracy	10
10 Manual	10
11 Marking	11
Annex A (normative) Density and compressibility of pure water	12
Annex B (normative) Density of moist air	17
Annex C (informative) Bibliography	20

iTeh STANDARD PREVIEW
(standards.iteh.ai)

[ISO 15212-1:1998](https://standards.iteh.ai/catalog/standards/sist/4efbb1aa-47ab-420e-8ed7-20c5998402b5/iso-15212-1-1998)

<https://standards.iteh.ai/catalog/standards/sist/4efbb1aa-47ab-420e-8ed7-20c5998402b5/iso-15212-1-1998>

Foreword

ISO (the International Organization for Standardization) is a worldwide federation of national standards bodies (ISO member bodies). The work of preparing International Standards is normally carried out through ISO technical committees. Each member body interested in a subject for which a technical committee has been established has the right to be represented on that committee. International organizations, governmental and non-governmental, in liaison with ISO, also take part in the work. ISO collaborates closely with the International Electrotechnical Commission (IEC) on all matters of electrotechnical standardization.

Draft International Standards adopted by the technical committees are circulated to the member bodies for voting. Publication as an International Standard requires approval by at least 75 % of the member bodies casting a vote.

International Standard ISO 15212-1 was prepared by Technical Committee ISO/TC 48, *Laboratory glassware and related apparatus*, Subcommittee SC 4, *Density measuring instruments*.

ISO 15212 consists of the following parts, under the general title *Oscillation-type density meters*:

— *Part 1: Laboratory instruments*

— *Part 2: Process instruments for liquids*

Annexes A and B form an integral part of this part of ISO 15212. Annex C is for information only.

iTeh STANDARD PREVIEW
(standards.iteh.ai)
<https://standards.iteh.ai/catalog/standards/sist/4efbb1aa-47ab-420e-8ed7-20c5998402b5/iso-15212-1-1998>

Oscillation-type density meters —

Part 1: Laboratory instruments

1 Scope

This part of ISO 15212 specifies metrological and other requirements for oscillation-type density meters which are used in laboratories for all kinds of homogeneous fluid samples. In addition, a method for adjustment and calibration of laboratory instruments is given. The instruments are either stand-alone units or part of more complex measuring equipment supplying additional test parameters of the sample.

This part of ISO 15212 does not describe the method of use of density meters for particular applications or products such as petroleum products or beverages. Such methods of use can be defined by relevant institutions such as ISO or responsible government agencies.

This part of ISO 15212 does not define an instrument specification for any particular application. For this information reference should be made to the relevant standard covering the method of use.

This part of ISO 15212 is addressed to manufacturers of density meters and to bodies testing and certifying the conformity of density meters. In addition, this part of ISO 15212 gives recommendations for adjustment and calibration of density meters by the user.

2 Normative references

The following standards contain provisions which, through reference in this text, constitute provisions of this part of ISO 15212. At the time of publication, the editions indicated were valid. All standards are subject to revision, and parties to agreements based on this part of ISO 15212 are encouraged to investigate the possibility of applying the most recent editions of the standards indicated below. Members of IEC and ISO maintain registers of currently valid International Standards.

ISO 3585:1998, *Borosilicate glass 3.3 — Properties*.

ISO 3696:1987, *Water for analytical laboratory use — Specification and test methods*.

IEC 61010-1:1990, *Safety requirements for electrical equipment for measurement, control and laboratory use — Part 1: General requirements*.

IEC 61326-1:1997, *Electrical equipment for measurement, control and laboratory use — EMC requirements — Part 1: General requirements*.

IEC 61326-1:—¹), Amendment 1.

¹) To be published.

3 Definitions

For the purposes of this part of ISO 15212, the following definitions apply.

NOTE The definitions and terms used are in agreement with the "*International Vocabulary of Basic and General Terms in Metrology*".

3.1

adjustment (of a density meter)

operation of bringing the instrument to a state of performance suitable for its use, by setting or adjusting the density instrument constants

NOTE By adjustment, systematic measuring deviations are removed to an extent which is necessary for the provided application. Adjustment demands an intervention which permanently modifies the instrument.

3.2

calibration (of a density meter)

set of operations that establishes the relationship between the reference density of standards and the corresponding density reading of the instrument

NOTE By calibration, no intervention is made which permanently modifies, for example, the instrument constants set during the adjustment procedure.

3.3

parasitic resonant points (of a density meter)

those oscillation frequencies at which the natural frequency of the density sensor is affected by oscillations of the "counter mass", comprising the rest of the instrument

ITeH STANDARD PREVIEW
(standards.iteh.ai)

4 Principle and functional units

4.1 Measuring principle

ISO 15212-1:1998

[https://standards.iteh.ai/catalog/standards/sist/4efbb1aa-47ab-420e-8ed7-](https://standards.iteh.ai/catalog/standards/sist/4efbb1aa-47ab-420e-8ed7-20c5998402b5/iso-15212-1-1998)

[20c5998402b5/iso-15212-1-1998](https://standards.iteh.ai/catalog/standards/sist/4efbb1aa-47ab-420e-8ed7-20c5998402b5/iso-15212-1-1998)

The sensors used in density meters are electrically or mechanically induced oscillating systems, whose oscillation frequencies or periods are a function of the sample density. Depending on the sensor design, the sensor can either contain the fluid sample or be immersed in it. Instrument constants of the adjusted density meter are used to calculate the sample density from the oscillation frequency or oscillation period.

4.2 Functional units

Oscillation-type density meters shall consist of the following functional units:

- a) a density sensor capable of either being filled with the sample or of being immersed in it;
- b) a device to excite and control sensor oscillation;
- c) a device to determine and display the density and the oscillation frequency or period;
- d) a device to determine and display the sample temperature for which the measured density is valid;
- e) a system to detect and display malfunctions and operator errors.

The functional units a) to c) are designated as the oscillation system. In addition, oscillation-type density meters can incorporate the following functional units:

- f) a unit for controlling the temperature of the sample and density sensor;
- g) sampling devices;
- h) sensor cleaning devices.

All functional units a) to h) can be integrated into a single instrument or can be separate units.

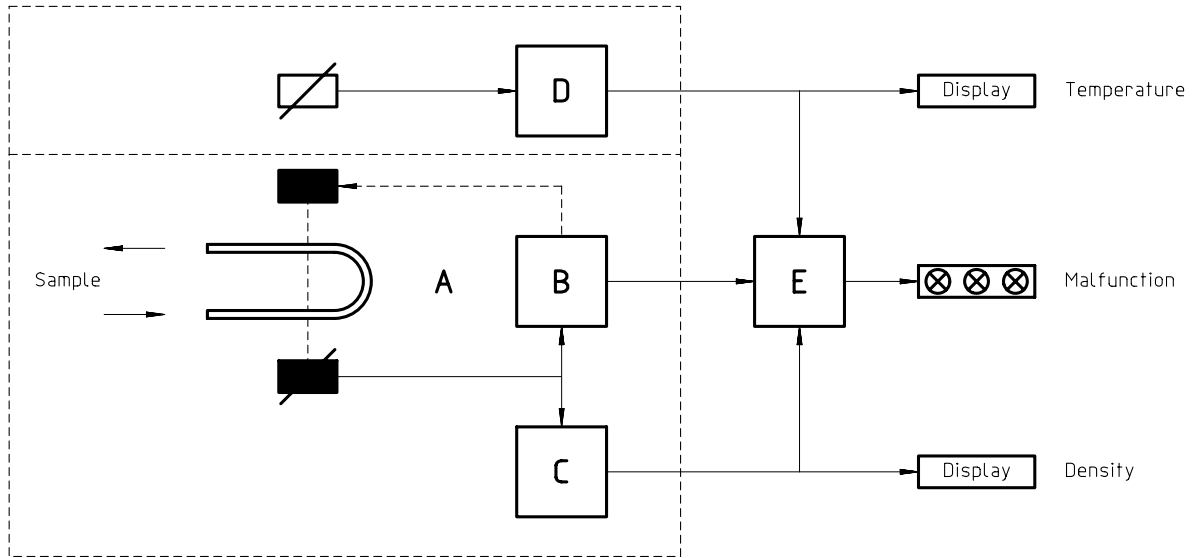

Key

- | | | | |
|---|-------------------------------|---|--------------------------------|
| A | Density sensor (4.2a) | D | Temperature measurement (4.2d) |
| B | Excitation transmitter (4.2b) | E | Functional monitoring (4.2e) |
| C | Signal evaluation (4.2c) | | |

Figure 1 — Functional units of a density meter
(standards.iteh.ai)

5 Density sensor

ISO 15212-1:1998

5.1 Sensor material <https://standards.iteh.ai/catalog/standards/sist/4efbb1aa-47ab-420e-8ed7-20c5998402b5/iso-15212-1-1998>

Density sensor materials can be, for example, borosilicate glass 3.3 in accordance with ISO 3585, metal, metal alloys or plastics. The material is considered to be suitable if it shows in resistance tables the highest class of resistance against the samples to be measured and the cleaning agents to be used in the density meter. Erosion as well as special forms of corrosion shall be considered in this respect. Where there is no literature or practical data available, the resistance of the sensor material should be tested as follows.

- Weigh a clean and dry test piece identical to the sensor material. The maximum permissible error of the balance shall not exceed 0,01 % of the test-piece mass.
- Immerse the test piece in the fluid to be measured with the sensor, under the intended measuring conditions, e.g. temperature and pressure.
- After 12 h remove, clean, dry and weigh the test piece.

The sensor material is considered to be resistant if the mass of the test piece is changed by the test procedure by less than $\pm 0,05$ %.

5.2 Sensor design

Density sensors can be designed as straight, U-formed or omega-formed tubes. Other designs are tuning-forks, cylinders, bells or membranes. All designs which conform to the functional principle in accordance with 4.1 can be constructed.

6 Requirements and tests

All the tests of clause 6 are intended to be type tests.

6.1 Oscillation system

6.1.1 Drift

6.1.1.1 Within 24 h, the drift of the displayed density $\Delta\rho_{24}$ at a constant temperature of 20 °C shall not exceed 1 % of the maximum permissible error specified by the manufacturer of the instrument.

If the density meter is not designed for a measuring temperature of 20 °C, the drift at the mean measuring temperature of the density meter shall not exceed 5 % of the specified maximum permissible error.

6.1.1.2 Switch on the instrument and allow the temperature to equilibrate for 24 h.

Adjust the instrument (see clause 7) in accordance with the manufacturer's instructions.

Fill the instrument three times and measure the density of water of Grade 2 in accordance with ISO 3696 at $(20 \pm 0,1)$ °C. Record the mean value of the threefold measurement ρ_1 .

Repeat the measurement (without a new adjustment) and repeat the mean value calculation ρ_2 after a minimum of 10 days. The instrument and thermostating device shall be in operation during the whole test procedure.

To calculate the drift, use the following equation:

$$\Delta\rho_{24} = \frac{\rho_2 - \rho_1}{\Delta t}$$

iTeh STANDARD PREVIEW
(standards.iteh.ai)

where Δt is the difference in days between the two threefold measurements.

If the density meter is not designed for a measuring temperature of 20 °C, testing shall be performed at the mean measuring temperature of the density meter.

6.1.2 Effect of sample viscosity

6.1.2.1 The oscillation system shall be constructed in such a way that the maximum permissible errors conform to the requirements of clause 9 when measuring samples of different viscosities and, where appropriate, with different sound velocities.

6.1.2.2 Use Newtonian liquids of known densities and viscosities as well as, where appropriate, known densities and sound velocities which suit the intended application of the density meter. The liquids shall be non-corrosive to the materials of the density sensor. Testing shall be performed in accordance with clause 9.

6.1.3 Deviation between sample and sensor temperatures

6.1.3.1 The oscillation system shall be constructed and built in such a way that the deviation between sample temperature and sensor temperature at the moment of display of the result does not exceed the values given in 6.2.

6.1.3.2 Check the displayed density of the instrument over a defined time period. For this

- switch on the instrument and set the measurement temperature to 20 °C;
- temperate the instrument for 24 h;
- precondition to 30 °C a reference liquid with high thermal density dependency;
- fill the density sensor with the preconditioned reference liquid.

The first density value displayed by the instrument as valid or read from the instrument after a time period specified by the manufacturer is compared with the density value displayed after 10 min. The difference between the two values shall not exceed 20 % of the maximum permissible error specified for the density meter by the manufacturer.

NOTE Bromobenzene or *n*-nonane are suitable examples of reference liquids for this test.

Warning: Bromobenzene is a hazardous substance and may not be permitted under Safety Regulations.

If the density meter is not designed for a measuring temperature of 20 °C, testing shall be performed at the mean measuring temperature of the density meter.

6.1.4 Effect of oscillations

6.1.4.1 Measurement deviations arising from the effect of oscillations of instrument parts on the density sensor shall not exceed 20 % of the maximum permissible error, specified for the density meter by the manufacturer, over the whole measuring range.

6.1.4.2 Examine the oscillatory characteristics of the built-in density sensor provided by the manufacturer. This test may not show, over the whole density measurement range, any parasitic resonant points (see 3.3) whose effects exceed 20 % of the maximum permissible error specified for the density meter by the manufacturer.

6.2 Temperature control and measurement

6.2.1 Requirement

The temperature sensor shall be built-in or a separate temperature unit shall be fitted in such a way that good thermal contact with the sample is guaranteed. The deviation between the displayed and actual sample temperatures shall not be greater than the maximum permissible error of the density meter multiplied by the factor $0,2 \text{ } ^\circ\text{C}\cdot\text{kg}^{-1}\cdot\text{m}^3$.

NOTE For the definition of this factor, an extreme thermal density deviation of $2,4 \text{ kg}\cdot\text{m}^{-3}\cdot\text{K}^{-1}$ has been assumed.

If the application range of the density meter is limited to aqueous samples and water-containing mixtures, the factor to be multiplied by the maximum permissible error can be increased to $0,5 \text{ } ^\circ\text{C}\cdot\text{kg}^{-1}\cdot\text{m}^3$.

6.2.2 Test conditions

The measurement of the temperature deviation between displayed and actual sample temperatures shall be performed by direct temperature measurement inside the density sensor or by indirect measurement.

The indirect test shall be performed by adjustment of the instrument (see clause 7), followed by calibration (see 8.4) of the density meter with two reference liquids, specially selected for this test (see 8.2), at the following test temperatures:

- at 20 °C;
- at a temperature near the lower limit of the temperature measurement range of the density meter; and
- at a temperature near the upper limit of the temperature measurement range.

If the density meter is not designed for the measurement temperature of 20 °C, the test shall be performed at the mean measurement temperature of the instrument.

The density values of the reference liquids, selected for this test (see 8.2), shall not exceed a density difference of $300 \text{ kg}\cdot\text{m}^{-3}$; the reference liquids shall have a different thermal density dependency $d\rho/d\theta$.

6.2.3 Test procedure

Clean the density sensor and switch on the instrument according to the manufacturer's instructions.

Attemperate the sensor at $(20 \pm 0,1) \text{ } ^\circ\text{C}$ for 24 h.

Adjust (see clause 7) the instrument according to the manufacturer's instructions.

Calibrate the instrument according to 8.4 using the first selected reference liquid according to 8.2. Record the error of measurement $\Delta\rho_3$.

Calibrate the instrument using the second selected reference liquid. Record $\Delta\rho_4$.

NOTE If the instrument has been adjusted (see clause 7) with water according to Grade 2 of ISO 3696, and if the reference liquid (see 8.2) for the first calibration is different from water, this second calibration may be omitted.

Repeat the test procedure at the two other temperatures.

6.2.4 Evaluation of the test

Calculate the viscosity correction $C_{\rho_3(\eta_3)}$ for the viscosity η_3 and density ρ_3 of the first reference liquid at the three test temperatures according to the manufacturer's instructions. Subtract the viscosity correction from the recorded error of measurement $\Delta\rho_3$:

$$C_{\rho_3} = \Delta\rho_3 - C_{\rho_3(\eta_3)}$$

Perform the same calculation for the second reference liquid:

$$C_{\rho_4} = \Delta\rho_4 - C_{\rho_4(\eta_4)}$$

Calculate the proximity value D_θ for the deviation between the indicated temperature and the actual sample temperature in the density sensor at each of the three test temperatures according to the equation:

$$D_\theta = 0,75 \times \frac{|C_{\rho_4} - C_{\rho_3}|}{\left| \left(\frac{d\rho_3}{d\theta} \right)_{\rho_3} - \left(\frac{d\rho_4}{d\theta} \right)_{\rho_4} \right|}$$

iTech STANDARD PREVIEW
(standards.iteh.ai)
ISO 15212-1:1998
iteh.ai/catalog/standards/sist/4efbb1aa-47ab-420e-8cd7-20c5998402b5/iso-15212-1-1998

where

$d\rho_3/d\theta$ is the thermal density dependency of the first reference liquid;

$d\rho_4/d\theta$ is the thermal density dependency of the second reference liquid.

NOTE 1 The correction factor 0,75 assumes that 25 % of the measurement deviations are not due to temperature deviations.

None of the three calculated proximity values D_θ shall exceed the maximum permissible error of the instrument multiplied by the factor 0,2 °C·m³·kg⁻¹ or 0,5 °C·m³·kg⁻¹.

NOTE 2 If the instrument has been adjusted with water according to Grade 2 of ISO 3696 and the second calibration has been omitted, the term C_{ρ_4} can be cancelled in the last equation and $d\rho_4/d\theta$ equals the thermal density dependency of water, calculated from the values given in table A.1 of annex A. Under these circumstances, *n*-nonane or *n*-dodecane are well suited reference liquids for this test. The thermal density dependencies are as follows:

$$d\rho_{non}/d\theta = -0,78 \text{ kg}\cdot\text{m}^{-3}\cdot\text{°C}^{-1}$$

$$d\rho_{dod}/d\theta = -0,73 \text{ kg}\cdot\text{m}^{-3}\cdot\text{°C}^{-1}$$

6.3 Displays

6.3.1 Display of results

The displays shall be designed in such a way that

- the density is displayed in kg/m³ or g/cm³ together with the measurement unit;
- the resolution of the density display on a digital scale corresponds to table 1;
- the scale interval on an analog scale is equal to the maximum permissible error (see table 1) and the spacing of the scale marks is 1 mm minimum.

Table 1 — Resolution and maximum permissible errors

Maximum permissible error kg/m ³	Resolution kg/m ³	Factor
1,0	0,1	1/10
0,5	0,1	1/5
0,20	0,01	1/20
0,10	0,01	1/10
0,05	0,01	1/5

Density instruments for special applications (e.g. scientific research) may have a resolution of the density display of 0,001 kg/m³ or 0,000 001 g/cm³, if the specified maximum permissible error does not exceed 0,1 kg/m³ or 0,0001 g/cm³ and if the least significant digit is unambiguously marked (e.g. by distinction in size or colour).

6.3.2 Additional displays

The displays shall be designed in such a way that

- the oscillation period or frequency is displayed on request and is clearly distinguished from the density display;
- the temperature of the liquid is displayed in degrees Celsius;
- the measurement unit is displayed together with the measurement value;
- the malfunctions are displayed;
- the instrument constants are displayed on request.

Additional instrument data, if available, may be displayed on request.

With a battery-powered density meter, the displayed values shall be clearly recognized as invalid if the lower or upper limit of the operating voltage is exceeded.

A visual check shall be carried out to ensure that the resolution of the density display complies with the manufacturer's specification in accordance with clause 9.

6.4 Auxiliary units and data transfer

If the density meter consists of several separated units or if additional devices are connected, the data shall be transferred unchanged and unaffected.