

Speech and multimedia Transmission Quality (STQ); Requirements and tests methods for terminal equipment incorporating a handset when connected to the analogue interface of the PSTN

iTeh STANDARD PREVIEW
(standards.iteh.ai)
Full standard:
<https://standards.iteh.ai/catalog/standards/sist/4e77a5d2-4bd8-4006-b4cf-60ed816b74a4/etsi-es-203-038-v1.1.1-2009-04>



Reference

DES/STQ-00129

Keywords

analogue, PSTN, telephony, terminal,

ETSI

650 Route des Lucioles
F-06921 Sophia Antipolis Cedex - FRANCE

Tel.: +33 4 92 94 42 00 Fax: +33 4 93 65 47 16

Siret N° 348 623 562 00017 - NAF 742 C
Association à but non lucratif enregistrée à la
Sous-Préfecture de Grasse (06) N° 7803/88

Important notice

Individual copies of the present document can be downloaded from:

<http://www.etsi.org>

The present document may be made available in more than one electronic version or in print. In any case of existing or perceived difference in contents between such versions, the reference version is the Portable Document Format (PDF). In case of dispute, the reference shall be the printing on ETSI printers of the PDF version kept on a specific network drive within ETSI Secretariat.

Users of the present document should be aware that the document may be subject to revision or change of status. Information on the current status of this and other ETSI documents is available at

<http://portal.etsi.org/tb/status/status.asp>

If you find errors in the present document, please send your comment to one of the following services:

http://portal.etsi.org/chaicor/ETSI_support.asp

Copyright Notification

No part may be reproduced except as authorized by written permission.
The copyright and the foregoing restriction extend to reproduction in all media.

© European Telecommunications Standards Institute 2009.
All rights reserved.

DECT™, **PLUGTESTS™**, **UMTS™**, **TIPHON™**, the TIPHON logo and the ETSI logo are Trade Marks of ETSI registered for the benefit of its Members.

3GPP™ is a Trade Mark of ETSI registered for the benefit of its Members and of the 3GPP Organizational Partners.

LTE™ is a Trade Mark of ETSI currently being registered

for the benefit of its Members and of the 3GPP Organizational Partners.

GSM® and the GSM logo are Trade Marks registered and owned by the GSM Association.

Contents

Intellectual Property Rights	6
Foreword.....	6
Introduction	6
1 Scope	7
2 References	8
2.1 Normative references	8
2.2 Informative references.....	9
3 Definitions, symbols and abbreviations	9
3.1 Definitions.....	9
3.2 Symbols.....	10
3.3 Abbreviations	10
4 Speech transmission aspects.....	10
4.1 General	10
4.1.1 Polarity independence.....	10
4.1.2 Feed conditions	11
4.1.3 Power supply	11
4.1.4 Volume control	11
4.1.5 Test setup.....	11
4.1.6 Environment for tests.....	12
4.1.7 Accuracy of measurements and test equipment setting	12
4.1.8 Order of tests.....	12
4.1.9 Acoustic environment.....	12
4.1.10 Alternative test methods	13
4.1.11 Testing arrangements.....	13
4.2 Speech performance characteristics.....	16
4.2.1 Sensitivity/frequency response	16
4.2.1.1 Sending Sensitivity	16
4.2.1.2 Receiving Sensitivity	17
4.2.2 Sending and Receiving Loudness Ratings (SLR and RLR).....	19
4.2.2.1 Sending Loudness Rating (SLR).....	19
4.2.2.2 Receiving Loudness Rating (RLR).....	19
4.2.3 Sidetone	20
4.2.4 Distortion	21
4.2.4.1 Sending distortion	21
4.2.4.2 Receiving distortion	22
4.2.5 Linearity (variation of gain with input level).....	23
4.2.5.1 Sending linearity	23
4.2.5.2 Receiving linearity	23
4.2.6 Noise.....	23
4.2.6.1 Sending noise	23
4.2.6.2 Receiving noise	24
4.2.7 Acoustic shock.....	24
4.2.7.1 Continuous signal.....	24
4.2.7.2 Peak signal	24
4.2.8 Instability	25
4.2.9 Echo Return Loss (ERL).....	26
Annex A (normative): Requirements for LRGP measured terminals.....	28
A.1 Speech transmission aspects.....	28
A.1.1 General	28
A.1.1.1 Polarity independence.....	28
A.1.1.2 Feed conditions	28
A.1.1.3 Power supply	28

A.1.1.4	Volume control	28
A.2	Speech performance characteristics	29
A.2.1	Sensitivity/frequency response	29
A.2.1.1	Sending Sensitivity	29
A.2.1.2	Receiving Sensitivity	29
A.2.2	Sending and Receiving Loudness Ratings (SLR and RLR).....	30
A.2.2.1	Sending Loudness Rating (SLR).....	30
A.2.2.2	Receiving Loudness Rating (RLR)	31
A.2.3	Sidetone	31
A.2.4	Distortion	31
A.2.4.1	Sending distortion	31
A.2.4.2	Receiving distortion	31
A.2.5	Linearity (variation of gain with input level).....	32
A.2.5.1	Sending linearity	32
A.2.5.2	Receiving linearity	32
A.2.6	Noise	32
A.2.6.1	Sending noise	32
A.2.6.2	Receiving noise	32
A.2.7	Instability	33
A.2.8	Echo Return Loss (ERL).....	33

Annex B (normative): Speech transmission compliance tests for LRGP measured terminals.....34

B.1	General conditions for testing	34
B.1.1	Environment for tests	34
B.1.2	Accuracy of measurements and test equipment setting.....	34
B.1.3	Order of tests	35
B.1.4	Acoustic environment.....	35
B.1.5	Handset mounting.....	35
B.1.6	Test levels.....	35
B.1.6.1	Sending	35
B.1.6.2	Receiving	35
B.1.6.3	Sidetone	35
B.1.7	Volume control.....	35
B.1.8	Test equipment requirements	36
B.1.9	Alternative test methods	36
B.1.10	Testing arrangements	36
B.2	Speech transmission performance tests for LRGP measured terminals	39
B.2.1	Sensitivity/frequency response	39
B.2.1.1	Sending sensitivity	39
B.2.1.2	Receiving sensitivity	39
B.2.2	Loudness ratings	40
B.2.2.1	Sending loudness rating	40
B.2.2.2	Receiving loudness rating	40
B.2.3	Sidetone.....	41
B.2.4	Distortion.....	42
B.2.4.1	Sending distortion	42
B.2.4.2	Receiving distortion	43
B.2.5	Linearity (variation of gain with input level)	43
B.2.5.1	Sending linearity	43
B.2.5.2	Receiving linearity	43
B.2.6	Noise	44
B.2.6.1	Sending noise.....	44
B.2.6.2	Receiving noise.....	44
B.2.7	Instability.....	45
B.2.8	Echo Return Loss (ERL)	47

Annex C (informative): Table of changes relative to TBR 38

Annex D (informative): Bibliography.....51

History52

iTeh STANDARD PREVIEW
(standards.iteh.ai)
Full standard:
<https://standards.iteh.ai/catalog/standards/sist/4e77a5d2-4bd8-4006-b4cf-60ed816b74a4/etsi-es-203-038-v1.1.1-2009-04>

Intellectual Property Rights

IPRs essential or potentially essential to the present document may have been declared to ETSI. The information pertaining to these essential IPRs, if any, is publicly available for **ETSI members and non-members**, and can be found in ETSI SR 000 314: "*Intellectual Property Rights (IPRs); Essential, or potentially Essential, IPRs notified to ETSI in respect of ETSI standards*", which is available from the ETSI Secretariat. Latest updates are available on the ETSI Web server (<http://webapp.etsi.org/IPR/home.asp>).

Pursuant to the ETSI IPR Policy, no investigation, including IPR searches, has been carried out by ETSI. No guarantee can be given as to the existence of other IPRs not referenced in ETSI SR 000 314 (or the updates on the ETSI Web server) which are, or may be, or may become, essential to the present document.

Foreword

This ETSI Standard (ES) has been produced by ETSI Technical Committee Speech and multimedia Transmission Quality (STQ).

The present document has been produced by ETSI in order to update the contents of initial standards for PSTN (e.g. TBR 38 [15]).

In particular, the update aims to take benefits of recent improvements in test methods and test equipments. Even the purpose of the standard is to consider Narrowband speech characteristics and test methods, the new test methods leave the door open for further services (e.g. wideband speech).

In this release 1 of the present document, no new measurement will be added except limitation of acoustic shock which is a requirement for safety. Previous requirements and test methods are kept in an annex in order to be used for terminals designed with LRGP method. Status of this annex is planned to be informative, but only in release 2.

The new measurements needed for handset terminal including speech processing functions will be introduced in a further release taking into account this type of terminal.

Introduction

The present document specifies only the technical characteristics for handset telephony and shall be used in conjunction with an appropriate access standard.

1 Scope

The present document specifies the technical characteristics (electrical and acoustic requirements and measurement methods) to be provided by a single, handset telephony, terminal equipment which is intended for connection by 2 wires to an analogue interface of a PSTN. This interface is characterized by a d.c. loop to indicate seizure and clearing, low frequency a.c. ringing signals below the speech passband to indicate an incoming call and the transmission phase having an approximate bandwidth of 3 kHz at the network terminating point.

The objective of the present document is to ensure minimum speech quality when interworking via the public network between two single items of equipment.

The present document only applies to terminal equipment supporting handset telephony.

The present document is applicable to handset telephony function. In the case of multiple functions provided in the same terminal equipment, the present document does not apply when those other functions are active in conjunction with handset telephony.

The present document also applies to any type of analogue handset terminal intended to be connected to a gateway.

The present document specifies the functions necessary to provide 2-way real-time speech conversation. Where a function is indicated as optional, it needs not to be provided, but, where such a function is provided, the terminal needs to conform to the requirements and tests specified in the present document.

A test is given for each requirement in the present document including measurement methods. The terminal equipment may be stimulated to perform the tests by additional equipment if necessary.

The present document gives requirements for new test methods based upon use of HATS and new test signals

In an annex, requirements with test methods corresponding to previous test methods (LRGP) and test signals are given.

The application of the present document is intended also for handset telephony function employing a radio link (e.g. DECT);

The application of the present document is not intended for:

- a handset telephony function with speech transmission performance specially designed for the less abled (e.g. with amplification of received speech as an aid for the hard of hearing);
- a handset telephony function with speech transmission performance specifically designed to cater for hostile environments;
- any handsfree or loudspeaking voice telephony function;
- a handset telephony function employing speech processing techniques other than coding.

NOTE: The terminal equipment may provide additional functions or facilities to those of handset telephony.

2 References

References are either specific (identified by date of publication and/or edition number or version number) or non-specific.

- For a specific reference, subsequent revisions do not apply.
- Non-specific reference may be made only to a complete document or a part thereof and only in the following cases:
 - if it is accepted that it will be possible to use all future changes of the referenced document for the purposes of the referring document;
 - for informative references.

Referenced documents which are not found to be publicly available in the expected location might be found at <http://docbox.etsi.org/Reference>.

NOTE: While any hyperlinks included in this clause were valid at the time of publication ETSI cannot guarantee their long term validity.

2.1 Normative references

The following referenced documents are indispensable for the application of the present document. For dated references, only the edition cited applies. For non-specific references, the latest edition of the referenced document (including any amendments) applies.

- [1] ITU-T Recommendation G.122 (03/93): "Influence of national systems on stability and talker echo in international connections".
- [2] ITU-T Recommendation P.64 (11/07): "Determination of sensitivity/frequency characteristics of local telephone systems".
- [3] ITU-T Recommendation P.51 (08/96): "Artificial mouth".
- [4] ITU-T Recommendation P.57 (11/05): "Artificial ears".
- [5] IEC 651: "Sound level meters".
- [6] ISO 3 (1973): "Preferred numbers - Series of preferred numbers".
- [7] ITU-T Recommendation P.79 (11/07): "Calculation of loudness ratings for telephone sets".
- [8] ITU-T Recommendation O.41 (10/94): "Psophometer for use on telephone-type circuits".
- [9] ETSI ES 200 677: "Public Switched Telephone Network (PSTN); Requirements for handset telephony".
- [10] ITU-T Recommendation P.50 (09/99): "Artificial voices".
- [11] ITU-T Recommendation P.56 (03/93): "Objective measurement of active speech level".
- [12] ITU-T Recommendation P.58 (08/96): "Head and torso simulator for telephony".
- [13] ITU-T Recommendation P.501 (09/01): "Test signals for use in telephony".
- [14] ETSI EG 202 518: "Speech Processing, Transmission and Quality Aspects (STQ); Acoustic Output of Terminal Equipment; Maximum Levels and Test Methodology for Various Applications".
- [15] ETSI TBR 38 (05/98): "Attachment requirements for a terminal equipment incorporating an analogue handset function capable of supporting the justified case service when connected to the analogue interface of the PSTN in Europe".

2.2 Informative references

The following referenced documents are not essential to the use of the present document but they assist the user with regard to a particular subject area. For non-specific references, the latest version of the referenced document (including any amendments) applies.

- [i.1] ITU-T Recommendation P 360 (07/06): "Efficiency of devices for preventing the occurrence of excessive acoustic pressure by telephone receivers and assessment of daily noise exposure of telephone users".
- [i.2] ITU-T Recommendation P.35 (1988, Blue Book): "Handset telephones".
- [i.3] ITU-T Recommendation P.65 (03/93): "Objective instrumentation for the determination of loudness ratings".
- [i.4] ETSI ES 202 738: "Speech Processing, Transmission and Quality Aspects (STQ); Transmission requirements for narrowband VoIP loudspeaking and handsfree terminals from a QoS perspective as perceived by the user".

3 Definitions, symbols and abbreviations

3.1 Definitions

For the purposes of the present document, the following terms and definitions apply:

artificial ear: device for the calibration of earphones incorporating an acoustic coupler and a calibrated microphone for the measurement of sound pressure and having an overall acoustic impedance similar to that of the average human ear over a given frequency band

diffuse field equalization: equalization of the HATS sound pick-up, equalization of the difference, in dB, between the spectrum level of the acoustic pressure at the ear Drum Reference Point (DRP) and the spectrum level of the acoustic pressure at the HATS Reference Point (HRP) in a diffuse sound field with the HATS absent (application of reverse nominal curve of table 3 in ITU-T recommendation P.58 [12])

Echo Return Loss (ERL): return loss averaged with 1/f power weighting over the telephone band (300 Hz to 3 400 Hz), in accordance with clause 4 of ITU-T Recommendation G.122 [1]

handset telephony: function provided by terminal equipment whereby two-way real-time speech is supported by means of a handset that forms an integral part of the terminal equipment

NOTE: The term "live speech" is also frequently used to describe "real-time speech". For the purposes of the present document, they should be considered as having the same meaning.

handset: combination of telephone microphone and receiver in a form convenient for holding simultaneously to mouth and ear, which, when in use, retains the microphone in a position fixed in relation to the receiver

handsfree function: function whereby telephony transmission and reception is facilitated by the use of microphone(s) and loudspeaker(s) placed at a distance from the user

NOTE: No handset is required to be used and normally the handset is not active.

Head And Torso Simulator (HATS) for telephonometry: manikin extending downward from the top of the head to the waist, designed to simulate the sound pick-up characteristics and the acoustic diffraction produced by a median human adult and to reproduce the acoustic field generated by the human mouth

loop state: state in which the TE draws sufficient DC current to activate the exchange

loop steady state: loop state excluding the transitions from and to quiescent state

loudness rating: measure, expressed in decibels, for characterizing the loudness performance of complete telephone connections or of parts thereof such as sending system, line, receiving system

loudspeaking function: function of a handset telephone using a loudspeaker associated with an amplifier as a telephone receiver

Mouth Reference Point (MRP): point 25 mm in front of and on the axis of the lip position of a typical human mouth (or artificial mouth)

nominal setting: setting of the volume control where the RLR is as close as possible to -8 dB

3.2 Symbols

For the purposes of the present document, the following symbols apply:

Ω	Ohm
dB	decibel
dBPa	sound pressure level with respect to 1 Pa, expressed in dB
dBPa(A)	"A" weighted sound pressure level with respect to 1 Pa, expressed in dB
dBV	voltage level with respect to 1 V, expressed in dB
dBVp	psophometrically weighted voltage level with respect to 1 V, expressed in dB

3.3 Abbreviations

For the purposes of the present document, the following abbreviations apply:

a.c.	alternating current
d.c.	direct current
e.m.f.	electromotive force
ERL	Echo Return Loss
ERP	Ear Reference Point
HATS	Head And Torso Simulator
ITU-T	International Telecommunications Union - Telecommunications sector
LRGP	Loudness Rating Guard-ring Position
MRP	Mouth Reference Point
Pa	Pascal
PSTN	Public Switched Telephone Network
r.m.s.	root mean square
RL	Return Loss
RLR	Receiving Loudness Rating
SLR	Sending Loudness Rating
SPL	Sound Pressure Level
STMTR	SideTone Masking Rating
TE	Terminal Equipment
V	Volt

4 Speech transmission aspects

4.1 General

4.1.1 Polarity independence

Requirement: The TE shall conform to the requirements of the present document for both polarities of line feeding voltage.

Test: Compliance shall be demonstrated by reversal of the d.c. voltage applied to the line terminals from test to test or between changes of test configuration when performing the tests of clause 4.2.

4.1.2 Feed conditions

Requirement: The TE shall conform to the requirements of the present document when tested with a supply voltage of 50 V and with feed resistances ranging from 500 Ω to 2 800 Ω .

NOTE: Some requirements are only specified for single or specific values of feed resistance.

Test: Compliance shall be demonstrated by performing the tests of clause 4.2 with the feed resistances specified in this clause.

4.1.3 Power supply

Requirement: Where the terminal handset function is intended to be used with power additional to that derived from the network, the requirements of clause 4.2 shall apply only when such additional power is provided and operating within specification.

Test: Compliance shall be demonstrated by performing the tests of clause 4.2 with the power supply connected and operative.

4.1.4 Volume control

Requirement: For TE with a user-controlled receiving volume control, the speech performance characteristics requirements apply with the user-controlled receiving volume control at the setting where the RLR is as close as possible to -8 dB, unless stated otherwise. This setting is to be taken as the nominal setting of the volume control.

Test: Compliance tests of clause 4.2 shall be carried out at the setting of the volume control where the RLR is as close as possible to -8 dB when measured with the feed resistance R_f set to 1 000 Ω , unless otherwise specified in the appropriate requirement.

NOTE: It is not necessary to strive to achieve values closer than 1 dB.

4.1.5 Test setup

Setup for handsets

The handset is placed in the HATS position as described in ITU-T Recommendation P.64 [2]. The artificial mouth shall be conform with ITU-T Recommendation P.58 [12]. The artificial ear shall be conform with ITU-T Recommendation P.57 [4], type 3.3 or type 3.4 ears shall be used.

Unless stated otherwise if a volume control is provided the setting is chosen such that the nominal RLR is met as close as possible.

Position and calibration of HATS

All the sending and receiving characteristics shall be tested with the HATS, it shall be indicated what type of ear was used at what application force. For handsets if not stated otherwise 8N application force shall be used.

The horizontal positioning of the HATS reference plane shall be guaranteed within $\pm 2^\circ$.

The HATS shall be equipped with a type 3.3 or type 3.4 artificial ear for handsets.

For all measurements except RLR, this signal is diffuse field corrected as described in ITU-T Recommendation P.58 [12] using the reverse nominal curve of Table 3. For RLR measurement, it is corrected by DRP to ERP correction as described in ITU-T Recommendation P.57 [4].

Informative note: For binaural headsets two artificial ears are required. The type 3.3 or type 3.4 artificial ears as specified in Recommendation P.57 [4] shall be used. The artificial ear shall be positioned on HATS according to ITU-T Recommendation P.58 [12].

4.1.6 Environment for tests

The following conditions shall apply for the testing environment:

- a) Ambient temperature: 15° C to 35° C (inclusive);
- b) Relative humidity: 5 % to 85 %;
- c) Air pressure: 86 kPa to 106 kPa (860 mbar to 1 060 mbar).

4.1.7 Accuracy of measurements and test equipment setting

Unless specified otherwise, the accuracy of measurements made by test equipment shall be equal to or better than:

Table 4.1: Accuracy of measurements

Item	Accuracy
Electrical signal level	±0,2 dB for levels ≥ -50 dBV ±0,4 dB for levels < -50 dBV
Sound pressure	±0,7 dB
Frequency	±0,2 %
Application force	±2 Newton

Unless specified otherwise, the accuracy of the signals generated by the test equipment shall be better than:

Table 4.2: Accuracy of signals

Quantity	Accuracy
Sound pressure level at Mouth Reference Point (MRP)	±3 dB for frequencies from 100 Hz to 200 Hz ±1 dB for frequencies from 200 Hz to 4 000 Hz ±3 dB for frequencies from 4 000 Hz to 8 000 Hz
Electrical excitation levels	±0,4 dB across the whole frequency range
Frequency generation	±2 % (see note)
Specified component values	±1 %
NOTE:	This tolerance may be used to avoid measurements at critical frequencies, e.g. those due to sampling operations within the terminal under test.

For terminal equipment which is directly powered from the mains supply, all tests shall be carried out within ±5 % of the rated voltage of that supply. If the equipment is powered by other means and those means are not supplied as part of the apparatus, all tests shall be carried out within the power supply limit declared by the supplier. If the power supply is a.c., the test shall be conducted within ±4 % of the rated frequency.

4.1.8 Order of tests

Tests are made in any order except where otherwise specified.

Where testing involves taking measurements using different feeding resistances, measurements shall be made with the highest feed resistance, then at lower values of resistance, decreasing sequentially to the minimum, in order to avoid a heating effect in the test arrangement.

4.1.9 Acoustic environment

Acoustic tests shall be carried out in an environment where the ambient noise is insufficient to influence the acoustic measurements being made.

Tests for noise and Echo Return Loss (ERL) shall be carried out in an environment where the ambient noise is less than -64 dBPa (A).

4.1.10 Alternative test methods

The requirements of this test specification were written on the basis of the standard test methods described in the present document. For some parameters it is recognized that alternative test methods may exist. It is the responsibility of the test house to ensure that any alternative method used is equivalent to that described in the present document.

For TE with adaptive modification of any transmission parameter dependent on the electrical operating conditions e.g. automatic adjustment of sidetone balance, each of the feed conditions for the compliance tests for the transmission parameters should be treated as a new installation and should be conditioned according to any instructions provided by the supplier.

4.1.11 Testing arrangements

All tests for transmission performance shall be carried out with the TE connected to the test arrangement shown in figure 4.1. The values of the feed resistance R_f are chosen appropriate to the requirement under test.

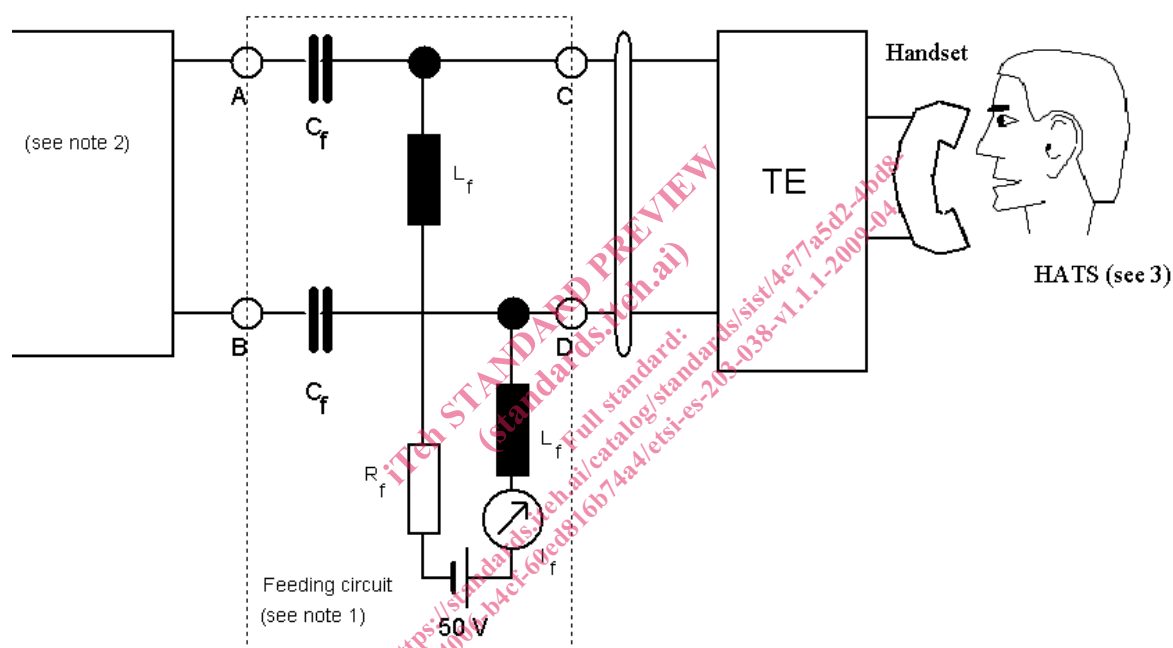

NOTE 1: The d.c. feeding circuit shown is an idealized arrangement. Performance requirements are given in figures 4.3 and 4.5.

NOTE 2: The equipment used for testing is connected between A and B and consists of the following as appropriate: a signal generator with an impedance of $600\ \Omega$, a measuring set, the network either of figures B.6, B.7, or B.8, or a $600\ \Omega$ resistor.

NOTE 3: The handset is placed in the HATS position as described in ITU-T Recommendation P.64 [2]. The artificial mouth shall conform with ITU-T Recommendation P.58 [12]. The artificial ear shall conform with ITU-T Recommendation P.57 [4], type 3.3 or type 3.4 ears shall be used.

Figure 4.1: Circuit for measurement of transmission characteristics

For sending measurements, signal is measured between A and B shown on figure 4.1.

For receiving measurements, signal is measured at the output of HATS's ear with corrections as given in clause 4.1.5.