



SLOVENSKI STANDARD
SIST EN 13525:2005+A1:2007

01-september-2007

Gozdarski stroji - Sekalniki - Varnost

Forestry machinery - Wood chippers - Safety

Forstmaschinen - Buschholzhacker - Sicherheit

Machines forestieres - Déchiqueteuses - Sécurité

Ta slovenski standard je istoveten z: EN 13525:2005+A1:2007

<https://standards.iteh.ai/catalog/standards/sist/fbf76226-eba4-4339-bff7-814201e13f40/sist-en-13525-2005a1-2007>

ICS:

65.060.80 Gozdarska oprema Forestry equipment

SIST EN 13525:2005+A1:2007 **en,fr,de**

iTeh STANDARD PREVIEW
(standards.iteh.ai)

SIST EN 13525:2005+A1:2007

<https://standards.iteh.ai/catalog/standards/sist/fbf76226-eba4-4339-bff7-814201e13f40/sist-en-13525-2005a1-2007>

English Version

Forestry machinery - Wood chippers - Safety

Machines forestières - Déchiqueteuses - Sécurité

Forstmaschinen - Buschholzhacker - Sicherheit

This European Standard was approved by CEN on 8 December 2004 and includes Amendment 1 approved by CEN on 13 April 2007.

CEN members are bound to comply with the CEN/CENELEC Internal Regulations which stipulate the conditions for giving this European Standard the status of a national standard without any alteration. Up-to-date lists and bibliographical references concerning such national standards may be obtained on application to the CEN Management Centre or to any CEN member.

This European Standard exists in three official versions (English, French, German). A version in any other language made by translation under the responsibility of a CEN member into its own language and notified to the CEN Management Centre has the same status as the official versions.

CEN members are the national standards bodies of Austria, Belgium, Bulgaria, Cyprus, Czech Republic, Denmark, Estonia, Finland, France, Germany, Greece, Hungary, Iceland, Ireland, Italy, Latvia, Lithuania, Luxembourg, Malta, Netherlands, Norway, Poland, Portugal, Romania, Slovakia, Slovenia, Spain, Sweden, Switzerland and United Kingdom.

(standards.iteh.ai)

[SIST EN 13525:2005+A1:2007](https://standards.iteh.ai/catalog/standards/sist/f76226-eba4-4339-bff7-814201e13f40/sist-en-13525-2005a1-2007)

<https://standards.iteh.ai/catalog/standards/sist/f76226-eba4-4339-bff7-814201e13f40/sist-en-13525-2005a1-2007>



EUROPEAN COMMITTEE FOR STANDARDIZATION
COMITÉ EUROPÉEN DE NORMALISATION
EUROPÄISCHES KOMITEE FÜR NORMUNG

Management Centre: rue de Stassart, 36 B-1050 Brussels

Contents

	Page
Foreword.....	3
0 Introduction.....	4
1 Scope.....	5
2 Normative references.....	6
3 Terms and definitions.....	7
4 Safety requirements and/or measures.....	9
4.1 General.....	9
4.2 Operator controls.....	9
4.2.1 General.....	9
4.2.2 Starting the machine.....	9
4.2.3 Stopping the machine.....	10
4.2.4 Infeed stop control.....	10
4.2.5 Safety and reliability of control systems.....	14
4.3 Protection against mechanical hazards.....	15
4.3.1 Stability.....	15
4.3.2 Risk of break-up during operation.....	15
4.3.3 Hazards related to infeed components and chipping components.....	16
4.3.4 Risks due to ejected objects.....	18
4.3.5 Protection against access to moving power transmission parts.....	18
4.4 Protection against non-mechanical hazards.....	19
4.4.1 Noise.....	19
4.4.2 Hydraulic components.....	20
4.4.3 Hot surfaces.....	20
4.4.4 Electrical hazards.....	20
4.5 Preparation for transport and maintenance.....	21
5 Verification of the safety requirements and/or measures.....	22
5.1 General.....	22
5.2 Stability.....	22
5.3 Chipping components risk of break-up.....	23
5.4 Hot surfaces.....	23
5.4.1 Temperature measuring equipment.....	23
5.4.2 Test method.....	23
5.4.3 Test acceptance.....	24
5.5 Verification of requirements on noise – Measurement of noise emission.....	24
6 Information for use.....	24
6.1 Instruction handbook.....	24
6.2 Marking.....	26
6.3 Warnings.....	26
Annex A (normative) List of significant hazards.....	28
Annex B (normative) Noise test code - Engineering method (grade 2).....	32
Annex C (normative)  Machines with integrated feed chain conveyor.....	35
Annex ZA (informative) Relationship between this European Standard and the Essential Requirements of EU Directive 98/37/EC, amended by Directive 98/79/EC.....	38
Bibliography.....	39

Foreword

This document (EN 13525:2005+A1:2007) has been prepared by Technical Committee CEN/TC 144 "Tractors and machinery for agriculture and forestry", the secretariat of which is held by AFNOR.

This European Standard shall be given the status of a national standard, either by publication of an identical text or by endorsement, at the latest by November 2007 and conflicting national standards shall be withdrawn at the latest by November 2007.

This document includes Amendment 1, approved by CEN on 2007-04-13.

This document supersedes EN 13525:2005.

The start and finish of text introduced or altered by amendment is indicated in the text by tags $\boxed{A_1}$ $\boxed{A_1}$.

This document has been prepared under a mandate given to CEN by the European Commission and the European Free Trade Association, and supports essential requirements of EU Directive(s).

For relationship with EU Directive(s), see informative Annex ZA, which is an integral part of this document.

According to the CEN/CENELEC Internal Regulations, the national standards organizations of the following countries are bound to implement this European Standard: Austria, Belgium, Bulgaria, Cyprus, Czech Republic, Denmark, Estonia, Finland, France, Germany, Greece, Hungary, Iceland, Ireland, Italy, Latvia, Lithuania, Luxembourg, Malta, Netherlands, Norway, Poland, Portugal, Romania, Slovakia, Slovenia, Spain, Sweden, Switzerland and United Kingdom.

TECHNICAL STANDARD PREVIEW
(standards.iteh.ai)
SIST EN 13525:2005+A1:2007
<http://www.iteh.com/catalog/standards/sist/f76226-eba4-4339-bff7-814201e13f40/sist-en-13525-2005a1-2007>

0 Introduction

This document is a type C standard as stated in EN ISO 12100-1.

The machinery concerned and the extent to which hazards, hazardous situations and events are covered are indicated in the scope of this document.

When provisions of this type C standard are different from those, which are stated in type A or B standards, the provisions of this type C standard take precedence over the provisions of the other standards, for machines that have been designed and built according to the provisions of this type C standard.

iTeh STANDARD PREVIEW (standards.iteh.ai)

[SIST EN 13525:2005+A1:2007](https://standards.iteh.ai/catalog/standards/sist/fbf76226-eba4-4339-bff7-814201e13f40/sist-en-13525-2005a1-2007)

<https://standards.iteh.ai/catalog/standards/sist/fbf76226-eba4-4339-bff7-814201e13f40/sist-en-13525-2005a1-2007>

1 Scope

This document specifies safety requirements and their verification for design and construction of transportable, i.e. self-propelled, mounted, semi-mounted and trailed, wood chippers used in forestry, agriculture, horticulture and landscaping.

A1 This document applies to chippers, used when stationary, which are manually loaded with wood through a horizontal or near horizontal infeed chute and where the infeed action is performed by the chipping components acting as infeed components or by separate integrated infeed components such as rollers or chain conveyors integral to the infeed chute. The included wood chippers may be powered either by an external power take-off, hydraulics etc. or by an integral power source such as an internal combustion engine. **A1**

This document does not cover:

- requirements relating to national road regulations arising from transport between work sites;
- hazards arising from any self-propelled function;
- hazards arising from the transmission of power from an external power source – e.g. power take-off drive shafts;
- **A1** any machines where the infeed chute is fitted with an extension table or the integrated chain conveyor is protruding beyond the outermost lower edge of the infeed chute; **A1**
- hazards arising from the engine pull starting of an integral power source;
- hazards arising from mechanical loading;
- vertical infeed chute chippers; [SIST EN 13525:2005+A1:2007
http://www.tech.ai/catalog/standards/sist/fbf76226-eba4-4339-bff7-814201e13f40/sist-en-13525-2005a1-2007](http://www.tech.ai/catalog/standards/sist/fbf76226-eba4-4339-bff7-814201e13f40/sist-en-13525-2005a1-2007)
- electromagnetic aspects of the chippers;
- shredders/chippers to be covered by EN 13683;
- **A1** any machines where the infeed chute is fitted with a belt type conveyor;
- mechanical discharge systems. **A1**

This document deals with all significant hazards, hazardous situations and events relevant to wood chippers, when they are used as intended and under the conditions foreseen by the manufacturer (see Annex A).

In addition, it specifies the type of information to be provided by the manufacturer on the safe use of these machines.

It is not applicable to environmental hazards (except noise).

This document is not applicable to wood chippers which are manufactured before the date of publication of this document by CEN.

2 Normative references

The following referenced documents are indispensable for the application of this document. For dated references, only the edition cited applies. For undated references, the latest edition of the referenced document (including any amendments) applies.

EN 294:1992, *Safety of machinery – Safety distance to prevent danger zones being reached by the upper limbs*

EN 563:1994, *Safety of machinery – Temperatures of touchable surfaces – Ergonomics data to establish temperature limit values for hot surfaces*

EN 811:1996, *Safety of machinery – Safety distances to prevent danger zones being reached by the lower limbs*

EN 953:1997, *Safety of machinery – Guards – General requirements for the design and construction of fixed and movable guards*

EN 954-1:1996, *Safety of machinery – Safety-related parts of control systems – Part 1: General principles for design*

EN 982:1996, *Safety of machinery – Safety requirements for fluid power systems and their components – Hydraulics*

EN 1175-2:1998, *Safety of industrial trucks – Electrical requirements – Part 2: General requirements of internal combustion engine powered trucks*

EN 10025-2:2004, *Hot rolled products of structural steels – Part 2: Technical delivery conditions for non-alloy structural steels*

EN 60204-1:1997, *Safety of machinery – Electrical equipment of machines – Part 1: General requirements (IEC 60204-1:1997)*

EN 60529:1991, *Degrees of protection provided by enclosures (IP Code) (IEC 60529:1989)*

EN 60947-5-1:2004, *Low-voltage switchgear and controlgear – Part 5-1: Control circuit devices and switching elements – Electromechanical control circuit devices (IEC 60947-5-1:2003)*

EN ISO 3744:1995, *Acoustics – Determination of sound power levels of noise sources using sound pressure - Engineering method in an essentially free field over a reflecting plane (ISO 3744:1994)*

EN ISO 4871:1996, *Acoustics – Declaration and verification of noise emission values of machinery and equipment (ISO 4871:1996)*

EN ISO 9614-1:1995, *Acoustics – Determination of sound power levels of noise sources using sound intensity – Part 1: Measurements at discrete points (ISO 9614-1:1993)*

EN ISO 9614-2:1996, *Acoustics - Determination of sound power levels of noise sources using sound intensity - Part 2: Measurement by scanning (ISO 9614-2:1996)*

EN ISO 11201:1995, *Acoustics – Noise emitted by machinery and equipment – Measurement of emission sound pressure levels at a work station and at other specified positions – Engineering method in an essentially free field over a reflecting plane (ISO 11201:1995)*

EN ISO 11204:1995, *Acoustics – Noise emitted by machinery and equipment – Measurement of emission sound pressure levels at a work station and at other specified positions – Method requiring environmental corrections (ISO 11204:1995)*

EN ISO 11688-1:1998, *Acoustics — Recommended practice for the design of low-noise machinery and equipment — Part 1: Planning (ISO/TR 11688-1:1995)*

EN ISO 12100-1:2003, *Safety of machinery – Basic concepts, general principles for design – Part 1: Basic terminology, methodology (ISO 12100-1:2003)*

EN ISO 12100-2:2003, *Safety of machinery – Basic concepts, general principles for design – Part 2: Technical principles (ISO 12100-2:2003)*

ISO 4413:1998, *Hydraulic fluid power – General rules relating to systems*

ISO 11684:1995, *Tractors, machinery for agriculture and forestry, powered lawn and garden equipment – Safety signs and hazard pictorials – General principles*

IEC 60245-1:2003, *Rubber insulated cables – Rated voltages up to and including 450/750 V – Part 1: General requirements*

3 Terms and definitions

For the purposes of this document, the terms and definitions given in EN ISO 12100-1:2003 and the following apply.

3.1

wood chipper

machine designed to reduce wood into chips

3.2

chipping components

rotating disc or drum or similar device with cutting tools or screw arrangement that performs the chipping operation and may perform also the infeed operation

3.3

infeed components

rollers and/or conveyors which feed wood into the chipping components

3.4

loading

method of presenting wood to the machine

3.4.1

horizontal loading

method where the wood is presented to the machine from its side in a horizontal direction

3.4.2

manual loading

method where the wood is presented to the machine is done manually by the operator

3.5

infeed chute

device through which wood is fed and guided to the chipping components and which may also provide the required safety distances

A1 3.6

integrated chain conveyor

transporting system integral to the infeed chute using chain(s), which presents wood to the infeed components or to the chipping components A1

3.7

discharge chute

device through which the chipped material is guided away from the chipping components and which may also provide the required safety distances

3.8

run down time

time elapsed from the actuation of the stop control device until the chipping and/or infeed components come to a complete stop

3.9

reference plane

vertical imaginary plane (a) normal to the feed direction, at a point nearest to the operator (b) during the action of infeeding, where the distance between the infeed components is 25 mm or where the separation of the infeed components is at its minimum if this is greater than 25 mm or where the infeed is achieved by the chipping components alone, the point nearest the operator where the chipping components are accessible

3.10

type A machines

machines where, on level ground and with the infeed chute in its designated working position, the outermost lower edge of the infeed chute is 600 mm or more from the ground, see Figure 2

3.11

type B machines

machines where, on level ground and with the infeed chute in its designated working position, the outermost lower edge of the infeed chute is less than 600 mm from the ground, see Figure 3

3.12

tool tip circle

path described by the outermost point of the cutting tools when rotating around their axis

[SIST EN 13525:2005+A1:2007](https://standards.iteh.ai/catalog/standards/sist/f176226-eba4-4339-bf17-814201e13f40/sist-en-13525-2005a1-2007)

3.13

[https://standards.iteh.ai/catalog/standards/sist/f176226-eba4-4339-bf17-](https://standards.iteh.ai/catalog/standards/sist/f176226-eba4-4339-bf17-814201e13f40/sist-en-13525-2005a1-2007)

mechanical discharge system

[814201e13f40/sist-en-13525-2005a1-2007](https://standards.iteh.ai/catalog/standards/sist/f176226-eba4-4339-bf17-814201e13f40/sist-en-13525-2005a1-2007)

system that transports the chips away from the chipping mechanism (e.g. a belt conveyor or an auger) ^{A1}

Dimensions in millimetres

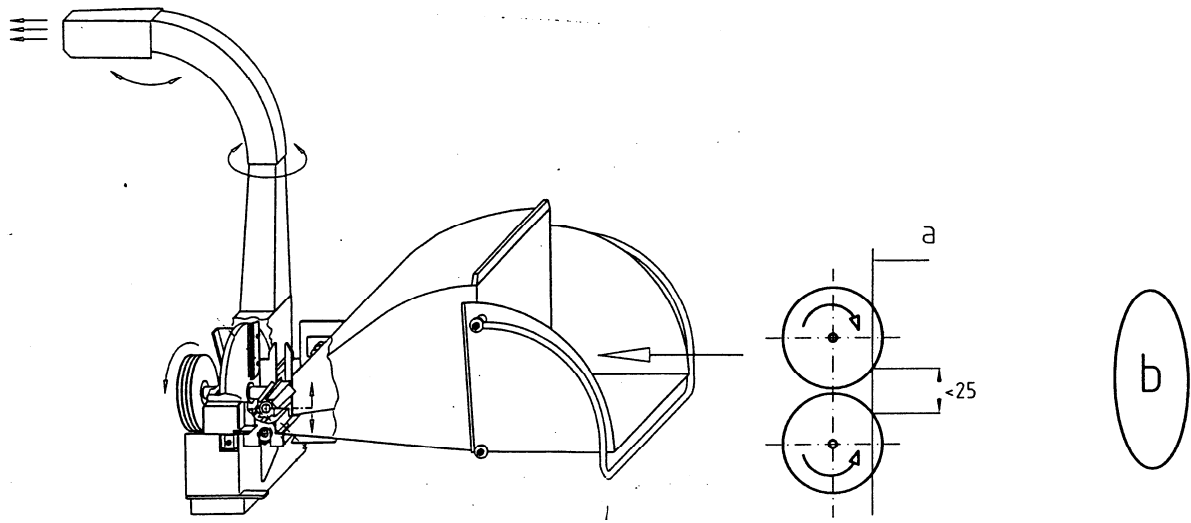
**Key**

a Reference plane

b Operator

NOTE This example is a functional representation of a wood chipper and does not illustrate the safety measures required by this document.

Figure 1 – Example of wood chipper and reference plane

4 Safety requirements and/or measures

SIST EN 13525:2005+A1:2007
<https://standards.iteh.ai/catalog/standards/sist/fbf76226-eba4-4339-bff7-814201e13f40/sist-en-13525-2005a1-2007>

4.1 General

Machines shall comply with the safety requirements and/or protective measures of this clause. In addition, the machine shall be designed according to the principles of EN ISO 12100 for hazards relevant but not significant, which are not dealt with by this document (e.g. sharp edges).

Unless otherwise specified in this document all opening and safety distances shall comply with Tables 1, 3, 4 and 6 of EN 294:1992 and other aspects shall comply with the relevant parts of EN ISO 12100.

4.2 Operator controls

4.2.1 General

All machines shall have separate controls for starting/stopping the chipping components and for starting/stopping the infeed action meeting the requirements given below in 4.2.2, 4.2.3, 4.2.4. The safety and reliability of control system shall meet the requirements given in 4.2.5. Controls for stopping the chipping components shall also stop the infeed action.

4.2.2 Starting the machine

4.2.2.1 Where the machine is powered by an external power source, e.g. a tractor power take-off or a hydraulic system, the tractor power-take-off start control or hydraulic system control is regarded as the operator's control for starting the chipping components, infeed components and integral conveyors (where fitted).

4.2.2.2 Where the machine is powered by an integral power source, e.g. an internal combustion engine or an electric motor, the engine or motor start is regarded as the operator's control for starting the chipping components, infeed components and integral conveyors (where fitted).

4.2.2.3 Where an electric starter is used to start the integral power source, unauthorised activation of the starter shall be avoided by using one or more of the following methods:

- a key operated ignition or starting switch;
- a lockable cover for the ignition or starting switch;
- a security ignition or starting lock;
- a lockable battery disconnection switch.

4.2.3 Stopping the machine

4.2.3.1 Where the machine is powered by an external power source, e.g. tractor power take-off or hydraulic system, the external power source stopping controls such as the tractors engine stop control, the tractor power take-off control or hydraulic system control are regarded as the operator's control for stopping the machine.

4.2.3.2 Where the machine is powered by an integral power source, e.g. an internal combustion engine or electric motor, the engine or motor stop is regarded as the operator's control for stopping the machine.

4.2.3.3 Where integral power source is an internal combustion engine, the engine stop control shall not require sustained manual pressure for its operation and when once actuated it shall not be possible to restart the engine unless the control has been reset.

4.2.4 Infeed stop control

[SIST EN 13525:2005+A1:2007
https://standards.iteh.ai/catalog/standards/sist/fbf76226-eba4-4339-bff7-814201e13f40/sist-en-13525-2005a1-2007](https://standards.iteh.ai/catalog/standards/sist/fbf76226-eba4-4339-bff7-814201e13f40/sist-en-13525-2005a1-2007)

4.2.4.1 General

All machines shall have an infeed stop control. The design, position and function of the infeed stop control shall allow the operator when in the designated operating position, if entangled in the wood being fed into the machine, to stop the infeed action. The operator shall be able to engage the infeed stop control, in the direction of infeed, by using parts of the body other than just the hands (e.g. shoulder, elbow, torso, hip, legs etc.). To achieve this, it shall meet the positional requirements given in 4.2.4.2 and functional requirements in 4.2.4.3.

Whilst these requirements shall be fulfilled, the design, position and function of the infeed stop control shall seek to minimise inadvertent activation (nuisance tripping) by wood and branches as they are fed into the machine; and opportunities for the operator to remove, disconnect, disable, defeat, or jam the control.

4.2.4.2 Positional requirements

4.2.4.2.1 The infeed stop control shall be located in accordance with either 4.2.4.2.2, see Figure 2 or 4.2.4.2.3, see Figure 3, as appropriate to the height of the outermost lower edge of the infeed chute. At the infeed chute vertical edges, the infeed stop control shall cover a minimum of 0,75 x h. At the relevant horizontal edge, top or bottom, the infeed stop control shall cover the entire width of the edge.

4.2.4.2.2 For type A machines, the infeed stop control shall be located at the sides and at the lower edge of the chute, see Figure 2.

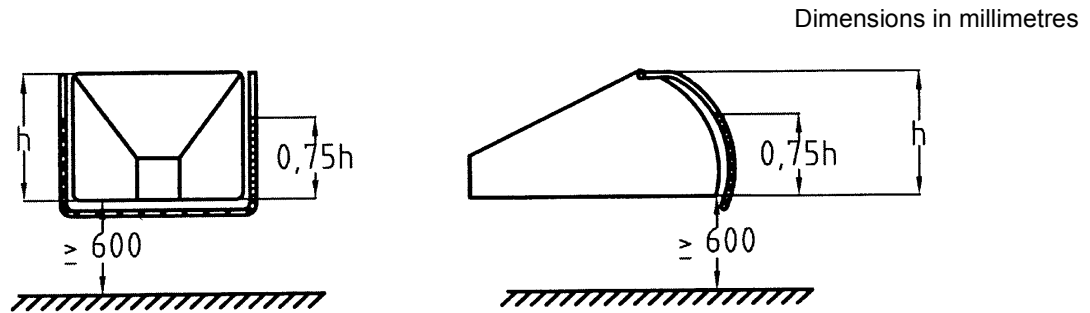
**Key**

h Height of the chute side

Figure 2 – Location and coverage of the infeed stop control on type A machines

4.2.4.2.3 For type B machines, the infeed stop control shall be located at the sides and at the upper edge of the chute, see Figure 3.

Dimensions in millimetres

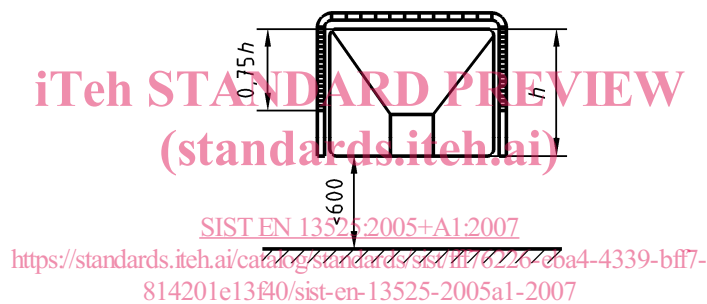
**Key**

h Height of the chute side

Figure 3 – Location and coverage of the infeed stop control on type B machines

4.2.4.2.4 In either location, the position of the infeed stop control in relation to the outermost edge of the infeed chute shall be in accordance with the appropriate Figure 4 or Figure 5 such that:

- all positions of the infeed stop control that allow or cause infeed action are in front of the outermost edge of the infeed chute, i.e. zone B;
- from those positions, the infeed stop control shall be able to be moved to a position known as the 'emergency stop position', i.e. position C; and
- this emergency stop position is in the position closest to the outermost edge of infeed chute but sufficiently in front of that edge for the emergency stop position to be successfully engaged, i.e. the respective operation completed, by the operator in the manner described in 4.2.4.1 in the event of entanglement.

4.2.4.2.5 The positions/functions of the infeed stop control shall be clearly indicated on both sides of the infeed chute and also in the instruction handbook. The colour of the infeed stop control shall be preferably red or yellow. Where other colours are used, they shall be bright and in contrast to the background colour of the infeed chute.