



SLOVENSKI STANDARD SIST EN 12350-4:2009

01-julij-2009

BUXca Yý U
SIST EN 12350-4:2001

DfYg_i ýUb^Y'gj YýY[UVYrcbU!(' "XY.'Grcdb^Un[cy Ybcgh]

Testing fresh concrete - Part 4: Degree of compactability

Prüfung von Frischbeton - Teil 4: Verdichtungsmaß

Essai pour béton frais - Partie 4 : Degré de compactabilité

iTeh STANDARD PREVIEW
(standards.iteh.ai)

Ta slovenski standard je istoveten z: EN 12350-4:2009

<https://standards.iteh.ai/catalog/standards/sist/c72a6c98-acfd-4ab6-aa45-cc72e0fad4a/sist-en-12350-4-2009>

ICS:

91.100.30 Beton in betonski izdelki Concrete and concrete products

SIST EN 12350-4:2009

en,fr

iTeh STANDARD PREVIEW
(standards.iteh.ai)

[SIST EN 12350-4:2009](#)

<https://standards.iteh.ai/catalog/standards/sist/c72a6c98-acfd-4ab6-aa45-cc72cf0fad4a/sist-en-12350-4-2009>

EUROPEAN STANDARD
NORME EUROPÉENNE
EUROPÄISCHE NORM

EN 12350-4

March 2009

ICS 91.100.30

Supersedes EN 12350-4:1999

English Version

Testing fresh concrete - Part 4: Degree of compactability

Essais pour béton frais - Partie 4 : Indice de serrage

Prüfung von Frischbeton - Teil 4: Verdichtungsmaß

This European Standard was approved by CEN on 20 January 2009.

CEN members are bound to comply with the CEN/CENELEC Internal Regulations which stipulate the conditions for giving this European Standard the status of a national standard without any alteration. Up-to-date lists and bibliographical references concerning such national standards may be obtained on application to the CEN Management Centre or to any CEN member.

This European Standard exists in three official versions (English, French, German). A version in any other language made by translation under the responsibility of a CEN member into its own language and notified to the CEN Management Centre has the same status as the official versions.

CEN members are the national standards bodies of Austria, Belgium, Bulgaria, Cyprus, Czech Republic, Denmark, Estonia, Finland, France, Germany, Greece, Hungary, Iceland, Ireland, Italy, Latvia, Lithuania, Luxembourg, Malta, Netherlands, Norway, Poland, Portugal, Romania, Slovakia, Slovenia, Spain, Sweden, Switzerland and United Kingdom.

(standards.iteh.ai)

SIST EN 12350-4:2009

<https://standards.iteh.ai/catalog/standards/sist/c72a6c98-acfd-4ab6-aa45-cc72cf0fad4a/sist-en-12350-4-2009>



EUROPEAN COMMITTEE FOR STANDARDIZATION
COMITÉ EUROPÉEN DE NORMALISATION
EUROPÄISCHES KOMITEE FÜR NORMUNG

Management Centre: Avenue Marnix 17, B-1000 Brussels

Contents

Page

Foreword.....	3
1 Scope	5
2 Normative references	5
3 Principle	5
4 Apparatus	5
5 Sampling	7
6 Procedure	7
7 Expression of results	7
8 Test report	8
9 Precision	8

iTeh STANDARD PREVIEW
(standards.iteh.ai)

[SIST EN 12350-4:2009](https://standards.iteh.ai/catalog/standards/sist/c72a6c98-acfd-4ab6-aa45-cc72cf0fad4a/sist-en-12350-4-2009)

<https://standards.iteh.ai/catalog/standards/sist/c72a6c98-acfd-4ab6-aa45-cc72cf0fad4a/sist-en-12350-4-2009>

Foreword

This document (EN 12350-4:2009) has been prepared by Technical Committee CEN/TC 104 “Concrete and related products”, the secretariat of which is held by DIN.

This European Standard shall be given the status of a national standard, either by publication of an identical text or by endorsement, at the latest by September 2009, and conflicting national standards shall be withdrawn at the latest by September 2009.

Attention is drawn to the possibility that some of the elements of this document may be the subject of patent rights. CEN [and/or CENELEC] shall not be held responsible for identifying any or all such patent rights.

This document supersedes EN 12350-4:1999.

This standard is one of a series concerned with testing concrete.

This series EN 12350 includes the following parts.

Part 1: Sampling;

Part 2: Slump-test;

Part 3: Vebe test;

Part 4: Degree of compactability;

Part 5: Flow table test;

Part 6: Density;

Part 7: Air content - Pressure methods;

Part 8: Self-compacting concrete - Slump-flow test (in preparation);

Part 9: Self-compacting concrete - V-funnel test (in preparation);

Part 10: Self-compacting concrete - L-box test (in preparation);

Part 11: Self-compacting concrete - Sieve segregation test (in preparation);

Part 12: Self-compacting concrete - J-ring test (in preparation).

CAUTION — When cement is mixed with water, alkali is released. Take precautions to avoid dry cement entering the eyes, mouth and nose whilst mixing concrete. Prevent skin contact with wet cement or concrete by wearing suitable protective clothing. If cement or concrete enters the eye, immediately wash it out thoroughly with clean water and seek medical treatment without delay. Wash wet concrete off the skin immediately.

iTeh STANDARD PREVIEW
(standards.iteh.ai)

[SIST EN 12350-4:2009](https://standards.iteh.ai/catalog/standards/sist/c72a6c98-acfd-4ab6-aa45-cc72cf0fad4a/sist-en-12350-4-2009)

<https://standards.iteh.ai/catalog/standards/sist/c72a6c98-acfd-4ab6-aa45-cc72cf0fad4a/sist-en-12350-4-2009>

EN 12350-4:2009 (E)

The following amendments have been made to the 1999-04 edition of this standard:

- editorial revision
- correcting the minimum frequency of the vibrating table from 2400 cycles per second into 2400 cycles per minute.

According to the CEN/CENELEC Internal Regulations, the national standards organizations of the following countries are bound to implement this European Standard: Austria, Belgium, Bulgaria, Cyprus, Czech Republic, Denmark, Estonia, Finland, France, Germany, Greece, Hungary, Iceland, Ireland, Italy, Latvia, Lithuania, Luxembourg, Malta, Netherlands, Norway, Poland, Portugal, Romania, Slovakia, Slovenia, Spain, Sweden, Switzerland and the United Kingdom.

iTeh STANDARD PREVIEW (standards.iteh.ai)

SIST EN 12350-4:2009

<https://standards.iteh.ai/catalog/standards/sist/c72a6c98-acfd-4ab6-aa45-cc72cf0fad4a/sist-en-12350-4-2009>

1 Scope

This European standard specifies a method for determining the consistence of fresh concrete by determining the degree of compactability.

It is not applicable to concrete of which the maximum size of aggregate exceeds 63 mm.

If the degree of compactability is less than 1,04 or more than 1,46, the concrete has a consistence for which the degree of compactability test is not suitable.

2 Normative references

The following referenced documents are indispensable for the application of this document. For dated references, only the edition cited applies. For undated references, the latest edition of the referenced document (including any amendments) applies.

EN 12350-1, *Testing fresh concrete — Part 1: Sampling*

3 Principle

Carefully place the fresh concrete in a container using a trowel, avoiding any compaction the concrete. When the container is full, the top surface is struck off level with the top of the container. The concrete is compacted by vibration and the distance from the surface of the compacted concrete to the upper edge of the container is used to determine the degree of compactability.

iTeh STANDARD PREVIEW
(standards.iteh.ai)
SIST EN 12350-4:2009
<https://standards.iteh.ai/catalog/standards/sist/c72a6c98-acfd-4ab6-aa45-cc72cf0fad4a/sist-en-12350-4-2009>

4 Apparatus

4.1 Container, made of metal not readily attacked by cement paste. The internal dimensions of the container shall be:

- base: (200 ± 2) mm \times (200 ± 2) mm;
- height: (400 ± 2) mm.

The thickness of the base and walls shall be at least 1,5 mm.

NOTE The bottom of the container may be perforated to facilitate emptying. A suitable plastic plate to cover the bottom has then to be placed inside the container.

4.2 Trowel, with a flat blade (see Figure 1).

Dimensions in millimetres

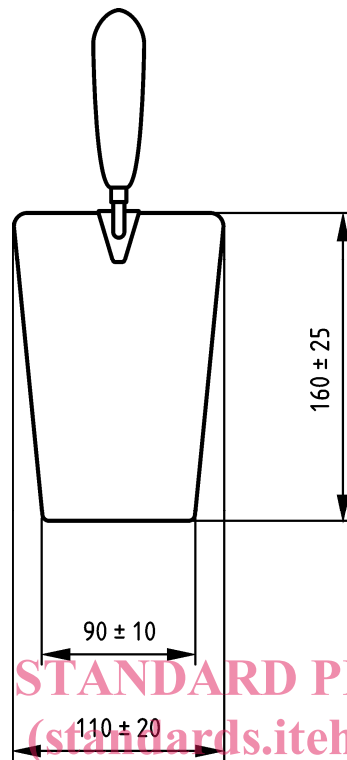

SIST EN 12350-4:2009
<https://standards.iteh.ai/catalog/standards/sist/c72a6c98-acfd-4ab6-aa45-cc72cf0fad4a/sist-en-12350-4-2009>
Figure 1 — Trowel

4.3 Means of compacting the concrete, which shall be one of the following:

- internal vibrator: with a minimum frequency of approximately 120 Hz (7 200 cycles per minute). The diameter of the internal vibrator shall not exceed one-quarter of the smallest dimension of the container;
- vibrating table: with a minimum frequency of approximately 40 Hz (2 400 cycles per minute).

The use of a vibrating table shall be the reference method.

4.4 Remixing container, flat tray of rigid construction and made from a non-absorbent material not readily attacked by cement paste. It shall be of appropriate dimensions such that the concrete can be thoroughly re-mixed, using the square-mouthed shovel.

4.5 Shovel, with square mouth.

NOTE The square mouth is required to ensure proper mixing of material on the remixing container.

4.6 Straight edged scraper, more than 200 mm in length

4.7 Rule, graduated from 0 mm to 300 mm, at intervals not exceeding 5 mm, the zero mark being at the extreme end of the rule.

4.8 Moist cloth.

5 Sampling

The sample shall be obtained in accordance with EN 12350-1.

The sample shall be re-mixed before carrying out the test.

NOTE Alternative sampling procedures may be given in national standards or provisions in the place of use of concrete.

6 Procedure

Clean the container and moisten the inner surfaces using a damp cloth.

Fill the container, without tamping it, by tilting the trowel sideways from each of all four upper edges of the container in turn. When the container is filled, remove all concrete above the upper edges, using the straight edged scraper with a sawing action, in such a way as to avoid any compacting effect.

Compact the concrete by means of a vibrating table or by the use of an internal vibrator, until no further reduction in volume is determinable. During compaction avoid loss of concrete through splashing, or leakage.

NOTE 1 Great care is recommended if loss of entrained air is to be avoided when using an internal vibrator.

After compaction, determine the value of s (see Figure 2), i.e.: the mean value of the distance between the surface of the compacted concrete and the upper edge of the container to the nearest millimetre. Obtain this value by measuring at the middle of each side of the container.

NOTE 2 The consistence of a concrete mix changes with time, due to hydration of the cement and, possibly, loss of moisture. Tests on different samples should, therefore, be carded out at a constant time interval after mixing, if strictly comparable results are to be obtained.

7 Expression of results

The degree of compactability c is given by the formula:

$$c = \frac{h}{h - s}$$

where

h is the internal height of the container, in millimetres;

s is the mean value, to the nearest millimetre, of the four distances from the surface of the compacted concrete to the upper edges of the container.

The result shall be reported to the nearest 0.01.