



**SLOVENSKI STANDARD**  
**SIST EN 13567:2002+A1:2007**  
**01-november-2007**

---

**Varovalna obleka - Varovala dlani, rok, prsnega koša, trebuha, nog, spolovil in obraza sabljačev - Zahteve in preskusne metode**

Protective clothing - Hand, arm, chest, abdomen, leg, genital and face protectors for fencers - Requirements and test methods

Schutzkleidung - Hand-, Arm-, Brustkorb-, Unterleibs-, Bein-, Genital- und Gesichtsschützer für Fechter - Anforderungen und Prüfverfahren

Vêtements de protection - Protection des mains, des bras, de la poitrine, de l'abdomen, des jambes, génitales et de la face pour les escrimeurs - Exigences et méthodes d'essai

<https://standards.iteh.ai/catalog/standards/sist/daba0528-c7a4-4921-8b05-a2d92bf93d32/sist-en-13567-2002+a1-2007>

**Ta slovenski standard je istoveten z: EN 13567:2002+A1:2007**

---

**ICS:**

13.340.10	Varovalna obleka	Protective clothing
97.220.30	Oprema za dvoranske športe	Indoor sports equipment

**SIST EN 13567:2002+A1:2007**                      **en,fr,de**

**iTeh STANDARD PREVIEW**  
**(standards.iteh.ai)**

[SIST EN 13567:2002+A1:2007](#)

<https://standards.iteh.ai/catalog/standards/sist/daba0528-c7a4-4921-8b05-a2d92bf93d32/sist-en-13567-2002a1-2007>

EUROPEAN STANDARD  
NORME EUROPÉENNE  
EUROPÄISCHE NORM

**EN 13567:2002+A1**

June 2007

ICS 13.340.10

Supersedes EN 13567:2002

English Version

**Protective clothing - Hand, arm, chest, abdomen, leg, genital  
and face protectors for fencers - Requirements and test  
methods**

Vêtements de protection - Protection des mains, des bras,  
de la poitrine, de l'abdomen, des jambes, génitales et de la  
face pour les escrimeurs - Exigences et méthodes d'essai

Schutzkleidung - Hand-, Arm-, Brustkorb-, Unterleibs-,  
Bein-, Genital- und Gesichtsschützer für Fechter -  
Anforderungen und Prüfverfahren

This European Standard was approved by CEN on 25 March 2002 and includes Amendment 1 approved by CEN on 10 May 2007.

CEN members are bound to comply with the CEN/CENELEC Internal Regulations which stipulate the conditions for giving this European Standard the status of a national standard without any alteration. Up-to-date lists and bibliographical references concerning such national standards may be obtained on application to the CEN Management Centre or to any CEN member.

This European Standard exists in three official versions (English, French, German). A version in any other language made by translation under the responsibility of a CEN member into its own language and notified to the CEN Management Centre has the same status as the official versions.

CEN members are the national standards bodies of Austria, Belgium, Bulgaria, Cyprus, Czech Republic, Denmark, Estonia, Finland, France, Germany, Greece, Hungary, Iceland, Ireland, Italy, Latvia, Lithuania, Luxembourg, Malta, Netherlands, Norway, Poland, Portugal, Romania, Slovakia, Slovenia, Spain, Sweden, Switzerland and United Kingdom.

<https://standards.iteh.ai/catalog/standards/sist/daba0528-c7a4-4921-8b05-a2d92bf93d32/sist-en-13567-2002a1-2007>



EUROPEAN COMMITTEE FOR STANDARDIZATION  
COMITÉ EUROPÉEN DE NORMALISATION  
EUROPÄISCHES KOMITEE FÜR NORMUNG

Management Centre: rue de Stassart, 36 B-1050 Brussels

## Contents

	page
Foreword.....	3
Introduction .....	4
1 Scope .....	4
2 Normative references .....	4
3 Terms and definitions .....	5
4 Requirements .....	9
4.1 General.....	9
4.2 Innocuousness.....	9
4.3 Ergonomic requirements .....	9
4.4 Restraint requirements .....	9
4.5 Sizing .....	9
4.6 Minimum dimensions of zones of protection .....	10
4.7 Construction materials and construction details.....	18
4.8 Penetration resistance.....	20
4.9 Burst strength of seams .....	22
5 Test methods.....	22
5.1 Instruments .....	22
5.2 Products for testing.....	22
5.3 Conditioning of products.....	23
5.4 Innocuousness.....	23
5.5 Ergonomic testing .....	23
5.6 Sizing .....	24
5.7 Examination of zones of protection.....	24
5.8 Restraint testing of masks.....	24
5.9 Bib attachment testing .....	25
5.10 Penetration testing .....	26
5.11 Burst testing.....	35
6 Marking .....	36
7 Information to be supplied by the manufacturer.....	36
Annex A (informative) Information about determining the chemical innocuousness of protective clothing and equipment .....	38
A.1 General.....	38
A.2 Evidence of innocuousness .....	38
A.3 Possible specific innocuousness testing .....	38
Annex B (informative) Levels of protection .....	40
B.1 Performance levels .....	40
B.2 Performance of combinations .....	40
B.3 Fencing jackets, breeches and underpants.....	40
B.4 Masks - bibs .....	41
Annex C (informative) Visors and masks made of material other than steel wire mesh .....	42
Annex ZA (informative) Clauses of this European Standard addressing essential requirements or other provisions of EU Directives.....	43
Bibliography .....	44

## Foreword

This document (EN 13567:2002+A1:2007) has been prepared by Technical Committee CEN/TC 162 "Protective clothing including hand and arm protection and lifejackets", the secretariat of which is held by DIN.

This document shall be given the status of a national standard, either by publication of an identical text or by endorsement, at the latest by December 2007 and conflicting national standards shall be withdrawn at the latest by December 2007.

This document includes Amendment 1, approved by CEN on 2007-05-10.

This document supersedes EN 13567:2002.

The start and finish of text introduced or altered by amendment is indicated in the text by tags A1 and A1.

This document has been prepared under a mandate given to CEN by the European Commission and the European Free Trade Association, and supports essential requirements of EU Directive(s).

For relationship with EU Directive(s), see informative Annex ZA, which is an integral part of this document.

According to the CEN/CENELEC Internal Regulations, the national standards organizations of the following countries are bound to implement this European Standard: Austria, Belgium, Bulgaria, Cyprus, Czech Republic, Denmark, Estonia, Finland, France, Germany, Greece, Hungary, Iceland, Ireland, Italy, Latvia, Lithuania, Luxembourg, Malta, Netherlands, Norway, Poland, Portugal, Romania, Slovakia, Slovenia, Spain, Sweden, Switzerland and United Kingdom.

## Introduction

Fencing by virtue of being a combat sport in which body contact by the weapon occasionally (but usually inadvertently) occurs outside the zones of protection, is by its nature dangerous. Protective clothing and equipment for fencers is intended as far as possible to prevent injuries, or in the worst cases to reduce the severity of injuries, particularly by the point of the weapon.

Broken blades pose a particular threat. The circumstances of the breakage of blades may result in high tip velocities and consequent high energy impacts by the broken blade. Broken blades have been known to penetrate protective equipment with fatal consequences. No practical clothing is capable of withstanding all broken blade impacts.

In this standard the concept of the 'optimum level of protection' has been taken into account. This concept is that the level of protection specified should be as high as it can be, without causing such unacceptable discomfort or impediment to fencing movements that fencers would not use the protective clothing.

The clothing specified in this standard provides two levels of protection perceived by the organisers and participants in the sport to be appropriate. Its use is expected to reduce risks of injuries to fencers to a tolerable level.

## 1 Scope

This European Standard specifies the general requirements for ergonomics, sizing, coverage and performance of protective clothing and equipment for use in the sport of fencing. Requirements for the marking of clothing and equipment and the information to be supplied by the manufacturer are given. Test methods are described and performance levels are defined.

**iTeh STANDARD PREVIEW**  
(standards.iteh.ai)  
[SIST EN 13567:2002+A1:2007  
https://standards.iteh.ai/catalog/standards/sist/daba0528-c7a4-4921-8b05-a2d92bf93d32/sist-en-13567-2002a1-2007](https://standards.iteh.ai/catalog/standards/sist/daba0528-c7a4-4921-8b05-a2d92bf93d32/sist-en-13567-2002a1-2007)

## 2 Normative references

This European Standard incorporates by dated or undated reference, provisions from other publications. These normative references are cited at the appropriate places in the text, and the publications are listed hereafter. For dated references, subsequent amendments to or revisions of any of these publications apply to this European Standard only when incorporated in it by amendment or revision. For undated references the latest edition of the publication referred to applies (including amendments).

EN 166:2001, *Personal eye-protection — Specifications*.

EN 388, *Protective gloves against mechanical risks*.

EN 420, *General requirements for gloves*.

EN 1082-1:1996, *Protective clothing — Gloves and arm guards protecting against cuts and stabs by hand knives — Part 1: Chain mail gloves and arm guards*.

EN ISO 5084:1996, *Textiles — Determination of thickness of textiles and textile products (ISO 5084:1996)*.

EN 13546:2002, *Protective clothing — Hand, arm, chest, abdomen, leg, foot and genital protectors for field hockey goal keepers, and shin protectors for field players — Requirements and test methods*.

EN 13595-3:2002, *Protective clothing for professional motorcycle riders — Jackets, trousers and one-piece or divided suits — Part 3: Test method for determination of burst strength*.

EN ISO 13938-1:1999, *Textiles — Bursting properties of fabrics — Part 1: Hydraulic method for determination of bursting strength and bursting distension (ISO 13938-1:1999)*.

EN ISO 13938-2:1999, *Textiles — Bursting properties of fabrics — Part 2: Pneumatic method for determination of bursting strength and bursting distension (ISO 13938-2:1999)*.

**A1** deleted text **A1**

ISO 3758, *Care labelling code using symbols*.

ISO 6330:2000, *Textiles — Domestic washing and drying procedures for textile testing*.

ISO 7500-1:1999, *Metallic materials — Verification of static uniaxial testing machines — Part 1: Torsion/compression testing machines – Verification and calibration of the force-measuring system*.

ISO 8559:1989, *Garment construction and anthropometric surveys — Body dimensions*.

### 3 Terms and definitions

For the purposes of this European Standard, the following terms and definitions apply.

#### 3.1

##### **protective clothing and equipment**

clothing and specific devices worn on the body, arms, hands and legs and over the face and neck, that are intended to reduce the severity of injuries from fencing weapons

#### 3.2

##### **zone of protection**

area of protective equipment that is intended to provide protection, and is subject to specific testing

#### 3.3

##### **coverage**

area of the fencer's body covered by the whole item of protective clothing or equipment and its attachments

#### 3.4

##### **garment**

unit of clothing which itself has an integral zone of protection replacing or in addition to an article of non-protective clothing

#### 3.5

##### **handedness**

designs and the markings on equipment that relate to its intended use by fencers holding their weapons in the right hands or left hands or whether the equipment is for ambidextrous use by right or left handed fencers

#### 3.6

##### **performance level**

number designating the level of the protection that it is intended the product should provide. This number is used in designating the test severity to which the product is to be subjected. For non-normative guidance on performance levels and the choice of equipment see annex B

#### 3.7

##### **fencing**

International and Olympic sport based on European duelling with swords and embracing disciplines characterised by the relevant weapons

#### 3.8

##### **weapon**

collective term covering the following specific swords used in fencing

**EN 13567:2002+A1:2007 (E)****3.8.1****foil**

rectangular section blade conventional duelling weapon with which hits are scored with the point only. The target is the anterior of the torso including the abdomen and the posterior torso down to the waist. The head, arms and legs are excluded, but are often hit

**3.8.2****epee**

traditional duelling weapon of V section blade with which hits are scored only with the point, and for which the target is the whole body, including the head and feet

**3.8.3****sabre**

weapon derived from the Cavalry sabre with a blunt cutting edge. Hits are scored with any part of the blade. The target is the whole body above the waist with the exception of the hands

**3.9****point**

expanded and/or flattened end of the blade of a weapon so designed as to reduce the possibility of the perforation of the protective clothing

**3.10****fencing mask**

protective device covering the face and sides of the head and the front of the neck. The parts are illustrated in

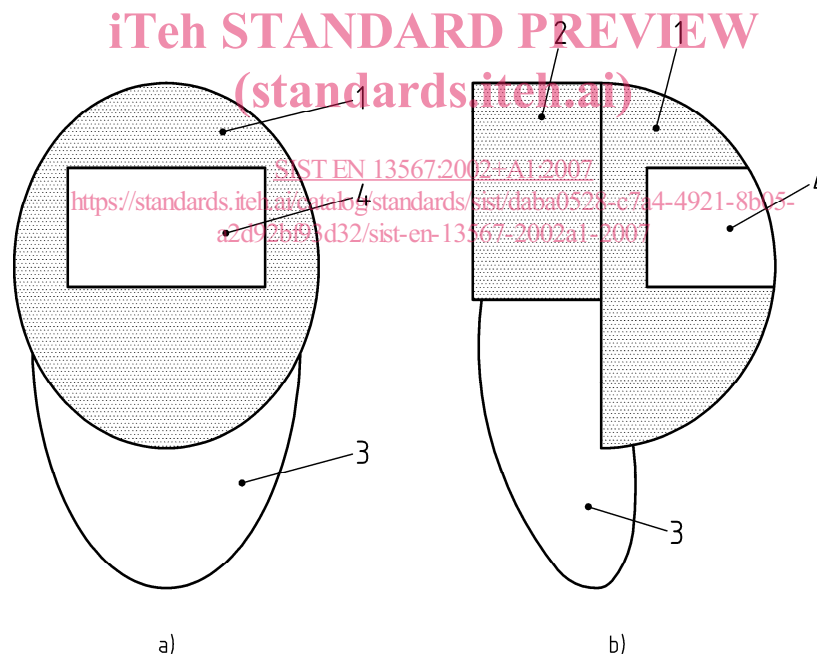
**Key**

a) Front view

b) Side view



1 Hard shell

2 Lateral protection

3 Bib

4 Visor (optional)

**Figure 1 — Component parts of a fencing mask**



**3.10.1****hard shell**

framework, part of which is see-through covering the face of the head

**3.10.2****lateral protection**

framework, part of which can be see-through covering the sides of the head and meeting over the top of the head

**3.10.3****mask bib**

protective element covering the front of the neck

**3.10.4****visor**

optional transparent area of the mask replacing part or all of the hard shell

**3.10.5****join**

any junction between the hard shell and visor, or hard shell or visor and the lateral protection

**3.10.6****see-through area**

region of the hard shell through which a fencer is able to see their opponent

**3.11****fencing clothing**

clothing designed specifically for the sport of fencing

iTeh STANDARD PREVIEW  
(standards.iteh.ai)

**3.11.1****fencing jacket**

garment covering the full length of both arms from the wrist to the shoulder, the chest and at least the upper part of the abdomen

SIST EN 13567:2002+A1:2007  
<https://standards.iteh.ai/catalog/standards/sist/daba0528-c7a4-4921-8b05-a2d92bf93d32/sist-en-13567-2002a1-2007>

**3.11.2****fencing breeches (trousers)**

garment covering the abdomen, thighs and knees (and occasionally the lower leg)

**3.11.3****fencing underpants**

protective garment covering the abdomen and upper half of the thigh. If used, this garment is worn inside the trousers

**3.11.4****(fencing) under plastron**

one armed garment worn under a jacket covering at least part of the weapon arm, the axilla (armpit) of the weapon arm and part of the chest wall on the same side

NOTE There are two-armed under plastrons which cover both of the fencer's arms. These are generally used by sabre fencers to reduce bruising.

**3.11.5****fencing gloves**

clothing covering the hand, wrist and part of the forearm of the fencer

**3.11.6****long fencing socks**

garments covering the feet and the lower part of the leg to just above the knee

**EN 13567:2002+A1:2007 (E)****3.12****fencing breast protector**

device worn over the breasts by lady fencers. The devices may be in one part or may consist of two, or may be elements for fitting into the inside of the front of the jacket or into the brassiere, or other garment

**3.13****genital protector**

device worn inside the trousers to protect the genitalia

**3.14****body dimensions****3.14.1****stature (height)**

vertical distance between the crown of the head and the ground measured with the subject standing upright without shoes and with their feet together

**3.14.2****chest girth**

maximum horizontal girth measured during normal breathing with the subject standing upright and the tape measure passed over the scapulae under the arm pits and across the chest

**3.14.3****bust girth**

maximum horizontal girth measured during normal breathing with the subject standing upright and the tape-measure passed over the scapulae under the armpits and across the breasts: normal underclothing to be worn

**3.14.4****under bust girth**

horizontal girth of the body immediately below the breasts measured as for the bust girth

**3.14.5****waist girth**

maximum horizontal girth measured during normal breathing with the subject standing upright and the tape-measure passed around the body in the plane of the waist, 50 mm above the supra-cristal plane which is at the level of the highest points of the iliac crests. The dimension 50 mm refers to a subject of 1 780 mm tall and should be scaled pro-rata with the height of the actual subject

**3.14.6****outside leg length**

distance from the waist to the ground, measured with the tape-measure following the contour of the hip

**A<sub>1</sub> 3.14.7****vertical circumference of the head**

circumference of the head measured with the measuring tape from the crown of the head, past the front of the ears and the rear of the jaw bone to meet underneath the jaw at the point where it joins the throat

NOTE See Figure 2.



Figure 2 — Illustration of the circumference of the head A<sub>1</sub>

## 4 Requirements

### 4.1 General

Protective clothing and equipment for fencers shall meet a general requirement that the product is safe to use and fit for its purpose and shall also meet the following specific requirements.

### 4.2 Innocuousness

Protective clothing and equipment for fencers shall be designed and manufactured to provide protection when used according to the manufacturer's instructions, without endangering the user or other players. There shall not be hard or sharp edges, seams, buckles or other items on the surfaces of the products that could harm the user or other players during normal use. Examination shall be made according to 5.4.

Construction materials and incorporated substances shall not harm those coming into contact with them. The manufacturer shall list in the information supplied with the product, the substances used in the main components of the product, and shall label any product containing substances or preparations generally known to be hazardous. Information about determining the chemical innocuousness of protective clothing and equipment is given in informative annex A.

### 4.3 Ergonomic requirements

Fencers' protective equipment shall be designed to minimise discomfort and impediment while wearing it. Fabrics in contact with the skin shall be wettable and not impermeable. The designs should permit normal fencing movements. The mask and visor shall not unduly distort the view of the user. The bib shall not cause the mask to be displaced when the user flexes their neck. The equipment shall be assessed according to 5.5.

### 4.4 Restraint requirements

Fencers' protective equipment shall be designed so that it should remain in place during normal use and during impacts. This restraint may be achieved using integral straps with buckles, touch and close fasteners, separate 'harness' or other items of protective equipment or clothing. The manufacturer shall give details of how adequate restraint of the equipment may be achieved in the information supplied by the manufacturer, see clause 7.

Fencers' masks shall not be pulled off a test subject's head when a force of 20 N is applied as described in 5.8, nor brought into contact with a test subject's face when tested with a force of 50 N as described in 5.8.

### 4.5 Sizing

Protective equipment shall be marked with its size (see clause 6). The size shall be related to the body dimensions of the fencers the equipment should fit, and this shall be explained in the information supplied by the manufacturer (see clause 7). The following body dimensions shall be used in sizing the protective equipment. Other dimensions may be used in addition. Definitions of some body dimensions are given in [A1](#) 3.14 [A1](#); others shall be determined by reference to ISO 8559:1989.

Jackets and under plastrons shall be sized against the users' chest or bust girth and stature.

Breeches and fencing underpants shall be sized against the users' waist girth and stature or outside leg measurement.

Gloves shall be sized against the users' hand length and hand breadth as described in EN 1082-1:1996, annex B, Table B1.

Socks shall be sized against the users' shoe size.

Breast protectors shall be sized according to brassiere and brassiere cup sizes as defined in ISO 8559, or against the user's bust girth or under bust girth.

**EN 13567:2002+A1:2007 (E)**

Fencing masks shall be sized according to their circumference as specified in Table 1 and measured according to 5.7.

Genital protectors shall be sized as specified in EN 13546:2002 for hard genital protectors.

**4.6 Minimum dimensions of zones of protection****4.6.1 General**

All protective equipment shall have a zone or zones, of protection, the dimensions of which shall be related to the size of the user. The dimensions and position of the zones of protection relative to the coverage provided by the whole equipment shall be given in the information supplied by the manufacturer (see clause 7). Where the dimensions of the coverage exceed those of the zone of protection by more than 15 mm in any direction, the outline of the zone of protection shall be clearly displayed. This may be by a line or a colour boundary on the inside or the outside of the equipment, or by a pictogram permanently attached to the equipment. It shall be possible to display the extent of the zone of protection where the garment is offered for sale.

**iTeh STANDARD PREVIEW**  
**(standards.iteh.ai)**

[SIST EN 13567:2002+A1:2007](https://standards.iteh.ai/catalog/standards/sist/daba0528-c7a4-4921-8b05-a2d92bf93d32/sist-en-13567-2002a1-2007)

<https://standards.iteh.ai/catalog/standards/sist/daba0528-c7a4-4921-8b05-a2d92bf93d32/sist-en-13567-2002a1-2007>

The dimensions of the zones of protection of clothing and equipment shall be measured as described in 5.7.

#### 4.6.2 Masks

Fencing masks shall have dimensions as shown in Table 1, and illustrated in Figure  $\boxed{A_1}$  3  $\langle A_1 \rangle$ . If a transparent visor is fitted there shall be a height of at least 40 mm of transparent material above the horizontal plane through the hard shell at the level of the mid point of dimension  $B$ , and at least 30mm of transparent material below this plane.

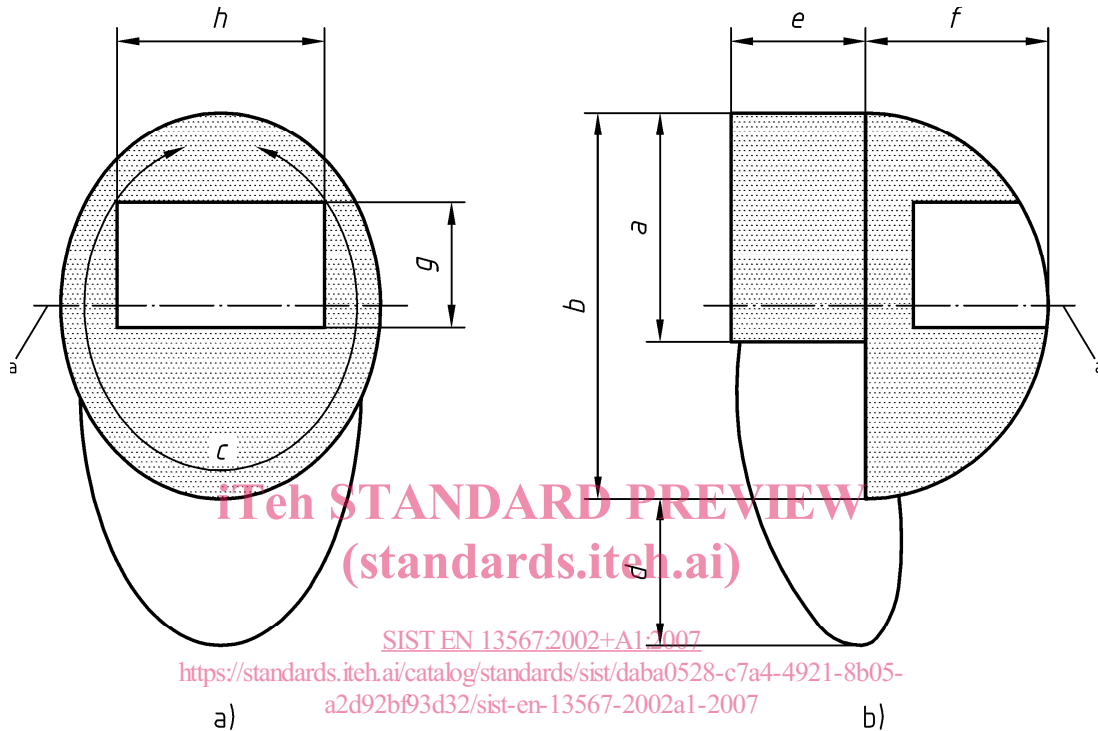

#### Key

$\boxed{A_1}$

a) Front view

b) Side view

$\langle A_1 \rangle$

$a/b$  The ratio of the vertical height of the lateral protection to the vertical height of the hard shell

$a$  Horizontal plane at the level of the mid point of dimension  $B$

$c$  The internal circumference of the hard shell measured on the inner surface of the padding

$d$  The depth of the bib

$e$  The width of the lateral protection

$f$  The front to back internal depth of the hard shell

$g$  The minimum vertical height of the transparent area of a visor if present

$h$  The minimum horizontal width of the transparent area of a visor if present

$\boxed{A_1}$  *deleted text*  $\langle A_1 \rangle$

Figure  $\boxed{A_1}$  3  $\langle A_1 \rangle$  — Fencing mask - Dimensions of component parts