CdfYa UĚ_jgYi dcfUV^UnUdf]dfUj c`d]fbYj cXYj`ghUj VU`!`AY Ubg_j]q]fj]!`&^XY.
:]f]nU]n`c]hYj`XYWj`n]j Y]_cght`cX`%±a`Xc`, \$`±a`Ě`NU hYj`Y`nUXYcj Ub^Z
j Ufbcgh]b`dfYg_i`yUb^Y

Water conditioning equipment inside buildings - Mechanical filters - Part 2: Particle rating
1 µm to less than 80 µm - Requirements for performance, safety and testing

Anlagen zur Behandlung von Trinkwasser innerhalb von Gebäuden - Mechanisch
wirkende Filter - Teil 2: Filterfeinheit 1 µm bis 80 µm - Anforderungen an Ausführung,
Sicherheit und Prüfung

Appareils de traitement d'eau a l'intérieur des bâtiments - Filtres mécaniques - Partie 2:
Particules de taille 1 µm a 80 µm - Exigences de performances, de sécurité et essais

Ta slovenski standard je istoveten z: EN 13443-2:2005+A1:2007

ICS:

13.060.20	Pitna voda	Drinking water
91.140.60	Sistemi za oskrbo z vodo	Water supply systems

SIST EN 13443-2:2005+A1:2007 en

iTeh STANDARD PREVIEW
(standards.iteh.ai)

SIST EN 13443-2:2005+A1:2007

<https://standards.iteh.ai/catalog/standards/sist/92a3c1bc-b9bd-4549-b1d2-e2d61fa3d258/sist-en-13443-2-2005a1-2007>

English Version

Water conditioning equipment inside buildings - Mechanical
filters - Part 2: Particle rating 1 μm to less than 80 μm -
Requirements for performance, safety and testing

Appareils de traitement d'eau à l'intérieur des bâtiments -
Filtres mécaniques - Partie 2: Particules de taille 1 μm à 80
 μm - Exigences de performances, de sécurité et essais

Anlagen zur Behandlung von Trinkwasser innerhalb von
Gebäuden - Mechanisch wirkende Filter - Teil 2:
Filterfeinheit 1 μm bis 80 μm - Anforderungen an
Ausführung, Sicherheit und Prüfung

This European Standard was approved by CEN on 24 December 2004 and includes Amendment 1 approved by CEN on 10 May 2007.

CEN members are bound to comply with the CEN/CENELEC Internal Regulations which stipulate the conditions for giving this European Standard the status of a national standard without any alteration. Up-to-date lists and bibliographical references concerning such national standards may be obtained on application to the CEN Management Centre or to any CEN member.

This European Standard exists in three official versions (English, French, German). A version in any other language made by translation under the responsibility of a CEN member into its own language and notified to the CEN Management Centre has the same status as the official versions.

CEN members are the national standards bodies of Austria, Belgium, Bulgaria, Cyprus, Czech Republic, Denmark, Estonia, Finland, France, Germany, Greece, Hungary, Iceland, Ireland, Italy, Latvia, Lithuania, Luxembourg, Malta, Netherlands, Norway, Poland, Portugal, Romania, Slovakia, Slovenia, Spain, Sweden, Switzerland and United Kingdom.



EUROPEAN COMMITTEE FOR STANDARDIZATION
COMITÉ EUROPÉEN DE NORMALISATION
EUROPÄISCHES KOMITEE FÜR NORMUNG

Management Centre: rue de Stassart, 36 B-1050 Brussels

Contents		Page
Foreword		3
1	Scope	4
2	Normative references	4
3	Terms and definitions	4
4	Symbols and abbreviations	8
5	Design requirements	9
6	Performance requirements	10
7	Test procedures	11
8	Technical documents, labelling and marking	38
Annex A (informative) Typical test reports		40
Annex B (informative) Typical graphical representation of test results		46
Annex C (normative) Integrity inspection and measurement of first bubble point		50
Annex D (normative)  Installation, operation and maintenance		53
Bibliography		57

[SIST EN 13443-2:2005+A1:2007
https://standards.iteh.ai/catalog/standards/sist/92a3c1bc-b9bd-4549-b1d2-e2d61fa3d258/sist-en-13443-2-2005a1-2007](https://standards.iteh.ai/catalog/standards/sist/92a3c1bc-b9bd-4549-b1d2-e2d61fa3d258/sist-en-13443-2-2005a1-2007)

Foreword

This document (EN 13443-2:2005+A1:2007) has been prepared by Technical Committee CEN/TC 164 "Water supply", the secretariat of which is held by AFNOR.

This document shall be given the status of a national standard, either by publication of an identical text or by endorsement, at the latest by December 2007 and conflicting national standards shall be withdrawn at the latest by December 2007.

This document includes Amendment 1, approved by CEN on 2007-05-10.

This document supersedes EN 13443-2:2005.

The start and finish of text introduced or altered by amendment is indicated in the text by tags $\boxed{A1}$ $\boxed{A1}$.

- a) this document provides no information as to whether the product may be used without restriction in any of the Member States.
- b) it should be noted that, while awaiting the adoption of verifiable European criteria, existing national regulation concerning the use and/or the characteristics of this product remain in force.

This is the second part of the two-part standard for mechanical filters. Part 1 is concerned with mechanical filters with a particle size rating from 80 μm to 150 μm .

According to the CEN/CENELEC Internal Regulations, the national standards organizations of the following countries are bound to implement this European Standard: Austria, Belgium, Bulgaria, Cyprus, Czech Republic, Denmark, Estonia, Finland, France, Germany, Greece, Hungary, Iceland, Ireland, Italy, Latvia, Lithuania, Luxembourg, Malta, Netherlands, Norway, Poland, Portugal, Romania, Slovakia, Slovenia, Spain, Sweden, Switzerland and United Kingdom.

1 Scope

This document specifies requirements relating to the construction, performance and methods of testing for mechanical filters for the removal of suspended matter in drinking water installations inside buildings. It applies to filters with a filtration rating from 1 μm up to less than 80 μm and which are intended for use in systems with a minimum pressure rating of PN 6, connections between DN 15 and DN 100 and service temperature of less than 30 °C.

This document is applicable to back-washable filters, integral filters and those designed for replaceable cartridges. It only concerns units that are permanently connected to the mains supply at point of entry or point of use.

Part 1 of this standard (EN 13443-1) is a separate document and deals with filters with a particle rating between 80 μm and 150 μm .

2 Normative references

The following referenced documents are indispensable for the application of this document. For dated references, only the edition cited applies. For undated references, the latest edition of the referenced document (including any amendments) applies.

EN 872, *Water quality — Determination of suspended solids — Method by filtration through glass fibre filters*

EN 1717, *Protection against pollution of potable water in water installations and general requirements of devices to prevent pollution by backflow*

EN 13443-1:2002, *Water conditioning equipment inside buildings — Mechanical filters — Part 1: Particle rating 80 μm to 150 μm — Requirements for performances, safety and testing*

ISO 304, *Surface active agents — Determination of surface tension by drawing up liquid films*

ISO 1219-1, *Fluid power systems and components — Graphic symbols and circuit diagrams — Part 1: Graphic symbols*

ISO 4021, *Hydraulic fluid power — Particulate contamination analysis — Extraction of fluid samples from lines of an operating system*

ISO 12103-1, *Road vehicles — Test dust for filter evaluation — Part 1: Arizona test dust*

3 Terms and definitions

For the purposes of this document, the following terms and definitions apply.

3.1

average pore diameter (DMP)

value, in μm , of the pore diameter which corresponds to the mode of the relative frequency of pore diameter distribution of a filter media determined by air porosimetry

3.2

backwashable filter

filter unit which is equipped with facilities, manual or automatic, to enable the periodic, in situ cleaning of the filter element by reversing the flow of water through the element

3.3

bubble point

lowest air pressure at which a stream of bubbles appears at a point of the filter media surface when immersed under air pressure in a wetting liquid in accordance with Annex C

4

3.4**cartridge filter**

filter unit comprising a housing and replaceable element

3.5**collapse pressure (ΔP_c)**

80 % of the differential pressure at the inflexion point

3.6**counting threshold**

electronic threshold for detecting particles of a given size

3.7**cumulative mean filtration efficiency per period (Ed_p)**

cumulative efficiency calculated from the total numbers of particles greater than size d counted upstream and downstream of a filter during the period p

3.8**cumulative overall mean filtration efficiency (Ed_g)**

cumulative efficiency calculated from the total number of particles greater than size d counted upstream and downstream of a filter during the whole test

3.9**depth filter**

filter element, comprising a thick porous barrier, with a pore size larger than the particles to be removed, such that the particles are trapped mainly within the depth of the element as water passes through it

3.10**differential pressure (dP)**

pressure difference between the inlet and outlet of the filter unit measured under predetermined conditions. The differential pressure generated by the complete filter is equal to the sum of the differential pressures generated by the housing and by the filter element

3.11**differential pressure at the inflexion point (dP_i)**

differential pressure across the filter unit including the cartridge at the inflexion point, minus the differential pressure generated by the test container alone (see Figure B.4)

3.12**drinking water**

water intended for human consumption as defined by Council Directive 98/83/EC (see [1])

3.13**fibre**

particle which is larger than 50 μm and for which the ratio of length to width is at least 10

3.14**filter cartridge**

replaceable filter element (spun, wound, pleated, ...)

3.15**filter element**

that part of a mechanical filter designed to retain particulate matter

3.16**filter housing**

pressure vessel which contains and seals the filter element and usually comprises the head, which usually embodies the connection, and the sump or body, which contains the element

3.17

filter system

complete installation comprising the filter housing, isolation valves, pressure gauges, pipework, etc.

3.18

final differential pressure (dP_F)

differential pressure of the filter element at the end of testing

3.19

inflexion point

point of discontinuity on a graph of pressure drop against solids loading curve, indicating deformation of the cartridge and potential solids break-through (see Figure B.4)

3.20

integral filter

complete filter for which the filter element and housing are inseparable

3.21

ISO Coarse Test Dust (ISO CTD)

siliceous test powder having a particle size distribution by convention between 0 μm and 200 μm in accordance with ISO 12103-1

NOTE It may also be referred to as ISO 12103-1 A4 dust.

3.22

ISO Medium Test Dust (ISO MTD)

siliceous test powder having a particle size distribution by convention between 0 μm and 80 μm in accordance with ISO 12103-1

NOTE It may also be referred to as ISO 12103-1 A3 dust.

3.23

mechanical filter

appliance designed to remove particulate matter from water by passage of the water through a porous medium

3.24

net differential pressure (dP_N)

difference between the final differential pressure of the clogged filter element and the differential pressure across the clean filter element (see 3.8)

3.25

nominal flow rate

flow rate for the filter specified by the manufacturer or, in the absence of this specification, the flow rate through the clean filter element at which the pressure drop across the filter element is 20 kPa

3.26

particle shedding

release of particles of the filter element construction material into the filtered water

3.27

reference filtration rating (S)

dimension, in μm , of the ISO MTD or ISO CTD particles at which the overall mean cumulative filtration efficiency of a filtering cartridge tested in accordance with the procedure described in this document, is greater than or equal to 99,8 %

3.28

retention capacity (C_R)

mass of ISO MTD or ISO CTD effectively retained by the filter element when the final standard differential pressure of 250 kPa is reached (C_{R250}) or a specific one of x kPa (C_{Rx}), calculated by subtraction of the mass of contaminant in the filtrate from the injected mass

3.29

surface filter

filter element comprising a thin permeable material, with a pore size smaller than the particles to be removed, such that the particles are trapped mainly on the surface of the material as the water passes through it

3.30

total mass of injected contaminant (M_i)

mass of ISO MTD or ISO CTD injected into the test circuit up to the point when the specified final differential pressure is reached

iTeh STANDARD PREVIEW
(standards.iteh.ai)

[SIST EN 13443-2:2005+A1:2007](https://standards.iteh.ai/catalog/standards/sist/92a3c1bc-b9bd-4549-b1d2-e2d61fa3d258/sist-en-13443-2-2005a1-2007)

<https://standards.iteh.ai/catalog/standards/sist/92a3c1bc-b9bd-4549-b1d2-e2d61fa3d258/sist-en-13443-2-2005a1-2007>

4 Symbols and abbreviations

The generic symbols and abbreviations used in this document are given in Table 1.

Table 1 — Symbols and abbreviations

Symbol or abbreviation	Parameter	Unit
C_e	Test concentration	mg/l
C_i	Injection concentration	mg/l
$C_{R2\ 500}$	Retention capacity at 2 500 kPa	g
C_{Rx}	Retention capacity at x kPa	g
CTD	Coarse Test Dust	-
ΔP	Differential pressure	kPa
ΔP_F	Final differential pressure	kPa
d	Size of the particle	μm
dP_c	Loss of pressure due to the test housing alone	kPa
dP_{eo}	Loss of pressure due to the clean filter alone	kPa
dP_F	Loss of pressure at the end of the test	kPa
dP_i	Loss of pressure at the point of inflexion	kPa
dP_o	Loss of pressure due to the test housing	kPa
dP_s	Loss of specific pressure	kPa
Ed	Cumulative filtration efficiency at the size greater than d μm	%
$E[d_1; d_2]$	Differential filtration efficiency (between the sizes d_1 and d_2)	%
M	Mass of contaminant necessary for the test	g
M_i	Total mass of injected contaminant	g
M_{NR}	Mass of non retained contaminant	g
MTD	Medium Test Dust	-
N_d	Number of particles having a dimension greater than or equal to d	-
$N[d_1; d_2]$	Number of particles having a dimension greater than or equal to d_1 and less than d_2	-
ΔP_N	Net differential pressure	kPa
Q_e	Test flow rate	l/min
Q_i	Injection flow rate	l/h
Q_{sensors}	Flow rate through the sensors	l/h
S	Reference filtration rating	μm
T_F	End of test time	min
V_i	Injection circuit fluid volume	l
V_{iM}	Injection circuit maximum fluid volume	l
V_F	Final fluid volume in test circuit	l
Δt_{100}	Time duration of a 100 mg/l period	min
P_T	Number of clogging periods (at 100 mg/l)	

The graphic symbols used conform to the requirements of ISO 1219-1.

5 Design requirements

5.1 Materials

The quality of the drinking water, after treatment by the filter, shall not be modified, by normal or accidental contact with the filter system materials or coatings, such that the treated water fails to comply with the Directive 98/83/EC, or the relevant national drinking water regulations, up to the design temperature of the filter.

5.2 Filter housings

Some cartridges are supplied separately from the housing as a universal fitting suitable for a number of different housings. The performance of a cartridge filter (cartridge and housing), particularly its particle rating, will be dependent upon the quality of the seal of the cartridge mount. Therefore, if the cartridge is supplied independently from the housing, the manufacturer, for compliance with this document, shall identify the housing, or range of housings, for which the cartridge is suitable.

5.3 Back-washable filters

Back-washable filters shall be capable of being cleaned, without the aid of tools and the cleaning mechanism shall meet the requirements of 5.1. After back-washing, the manufacturer's filtration rating and clean pressure drop shall be restored. Action to be taken in the event of irrecoverable deterioration in the performance of the filter should be defined in the manufacturer's instructions.

Back-washable filters shall be fitted with a free drain outlet in accordance with EN 1717.

Back-washable filters shall be designed so that there shall be no interruption of the water supply during the backwash operation.

5.4 Cartridge filters

Cartridge filters shall be designed such that the filter cartridge can be replaced with minimum risk of contamination of the drinking water supply.

Any tools used in this operation shall not come into contact with the drinking water and shall be provided by the filter manufacturer.

The cartridge sealing arrangement shall be designed to accommodate regular cartridge change without wear of the housing which could cause degradation of the efficiency of the filter over its lifetime.

Replacement cartridges shall be individually wrapped to prevent contamination in transport and storage.

NOTE It is recommended, particularly for point of use filters, that a device should be provided to warn the end-user when the cartridge has become fouled.

5.5 Integral filters

Integral filters shall be designed such that the filter unit can be changed without the use of special tools. They shall be installed allowing adequate access for the routine filter change operation.

5.6 Design temperature

The complete filter system shall be designed for continuous operation at a maximum ambient and water temperature of at least 30 °C.

5.7 Backflow prevention

Backflow prevention shall be provided in accordance with the national implementation of EN 1717.

6 Performance requirements

6.1 Reference filtration rating

The filter system or cartridge, when tested in the manufacturer's recommended housing, shall demonstrate a filtration efficiency of at least 99,8 % at the manufacturer's designated particle rating for the cartridge, and at the manufacturer's recommended maximum pressure drop, when tested in accordance with the method defined in 7.1.

6.2 Retention capacity

The retention capacity shall be not less than the manufacturer's declared value (if any), and tested in accordance with 7.2. This requirement is not applicable to back-washable filters.

6.3 Clean pressure drop

The manufacturer of the filter element shall identify in the appropriate documentation, the pressure drop through a clean cartridge at the manufacturer's recommended flow rate or the maximum acceptable pressure drop after backwash at the manufacturer's recommended flow rate (see Clause 8). The method for measurement of the clean pressure drop shall be in accordance with 7.3.

6.4 Maximum pressure drop

The manufacturer of the filter element shall specify in the appropriate documentation and/or on the filter element and/or on the filter housing, the maximum pressure drop at which it is recommended that the cartridge be changed.

6.5 Cartridge collapse pressure (standards.iteh.ai)

When subjected to continuous and progressive blinding, up to a pressure drop equivalent to 80 % of the nominal pressure rating of the housing, there shall be no discontinuity in the pressure rise, nor, after careful removal and cleaning, any visible damage to the cartridge, when tested in accordance with 7.4.

6.6 Cartridge cyclic differential pressure resistance

When subjected to a cyclic flow of water sufficient to generate a peak pressure drop of 200 kPa, or greater, at a cycle frequency of 0,05 Hz, for 500 cycles (see 7.5):

- a) the pressure drop at the peak flow rate, shall not fall off during the test,
- b) there shall be no visible evidence of damage to the filter cartridge and
- c) the bubble point for the cartridge after the test shall not differ from that measured before the test, by more than 15 %. The bubble point shall be measured in accordance with Annex C.

6.7 Particle shedding

When subjected to the manufacturer's recommended flow rate, a new cartridge, after preconditioning in accordance with the manufacturer's instructions (see Clause 8), shall show no increase in particle count when compared to the background particle count of the test rig, when tested in accordance with 7.6.

6.8 Housing resistance to static pressure

When subjected to a static pressure test as defined in EN 13443-1:2002, 7.2, the filter housing shall show no permanent, visible signs of leakage, permanent deformation, fissures or ruptures.

6.9 Housing resistance to cyclic pressure

When subjected to a cyclic pressure test as defined in EN 13443-1:2002, 7.4, the filter housing shall show no permanent, visible signs of leakage, permanent deformation, fissures or ruptures.

7 Test procedures

7.1 Reference filtration rating

7.1.1 Principle

The performance of the filter to be tested is determined by measuring its hydraulic and separative properties when subjected to a constant flow rate of water conveying a known quantity of contaminant. The test is performed with the water recycled after passage through a decontamination filter. The test is conducted in a succession of periods during which the concentration of the test contaminant upstream of the filter is alternated between 5 mg/l and 100 mg/l. The filtration efficiency and ratio are calculated from automatic, on line, particle counts upstream and downstream of the element during the low (5 mg/l) concentration periods. The retention capacity is determined from the mass of contaminant required for obtaining a predetermined differential pressure. Several operating parameters are specified as a function of the type of filter under test, e.g. the standard flow rate of 15 l/min is recommended for testing a standard 250 mm long cartridge.

iTeh STANDARD PREVIEW (standards.iteh.ai)

SIST EN 13443-2:2005+A1:2007

<https://standards.iteh.ai/catalog/standards/sist/92a3c1bc-b9bd-4549-b1d2-e2d61fa3d258/sist-en-13443-2-2005a1-2007>

7.1.2 Test equipment and materials

7.1.2.1 Test stand

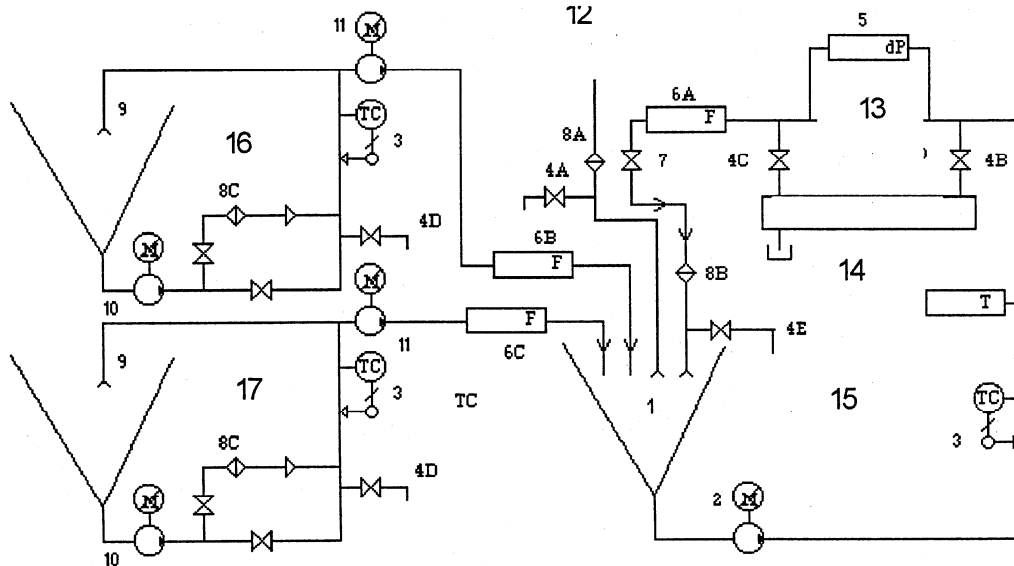

iTeh STANDARD PREVIEW
(standards.iteh.ai)

Key

- | | |
|----------------------------------|--------------------------------|
| 1 Main reservoir | 10 Recirculation pump |
| 2 Main pump | 11 Injection pump |
| 3 Temperature sensor regulator | 12 Micro-filtered water supply |
| 4 Sampling valve | 13 Filter to be tested |
| 5 Differential pressure gauge | 14 On line counts |
| 6 Flow meter | 15 Main circuit |
| 7 Counter pressure control valve | 16 Injection circuit n° 1 |
| 8 Decontamination filters | 17 Injection circuit n° 2 |
| 9 Injection reservoir | |

Figure 1 — Diagram of filtration efficiency and retention capacity test rig

7.1.2.1.1 Filter test circuit

The filter test circuit is designed in order to permit the recycling of the fluid being filtered. The return line is equipped with a decontamination filter that retains all of the test particles that have passed through the test filter.

The test circuit comprises:

- a) conical bottom reservoir having a recommended cone angle less than or equal to 90°. It shall have a retention time of 30 s and an aspect ratio of 2 to 3. The recycled water return line penetrates beneath the free face so as to avoid the risk of air entrainment;
- b) circulation pump which ensures a constant, non pulsed flow rate throughout the test duration, particularly when the filter is clogged. It shall be resistant to the test contaminant and it shall not modify its particle size distribution;
- c) decontamination filter to restore the level of the test fluid's particulate contamination to less than 300 particles greater than 5 µm per 100 ml. It shall be fitted with bypass and isolation valves;

- d) instruments for measuring the flow rate, the temperature, the relative and differential pressures at the filter connections. The pressure tappings are of the spur type;
- e) sampling devices in accordance with ISO 4021 are placed upstream and downstream of the filter in order to ensure representative sampling of the water and contaminant;
- f) interconnecting pipe and fittings, dimensioned and selected so as to ensure a turbulent flow throughout the whole circuit, thereby preventing the formation of traps, segregation and quiescent zones. The length of the piping shall be reduced to the minimum;
- g) clean water level control device in the test reservoir, which regulates the level to within 5 %;
- h) temperature regulator which controls the temperature at the specified value of (23 ± 2) °C.

7.1.2.1.2 Contaminant injection circuits

There are two injection circuits; one is allocated to 5 mg/l injection (injection circuit N° 1), the other to 100 mg/l injection (injection circuit N° 2).

Each injection circuit includes the following equipment:

- a) conical bottom reservoir having a recommended cone angle less than or equal to 90°. Its height is preferably between twice or three times its diameter. It is equipped with a level indicator. The recycled water returns beneath the free face;
- b) recirculation pump which generates a sufficient flow rate to ensure perfect mixing under all circumstances. It shall be resistant to the test contaminant and it shall not modify its particle size distribution. An additional stirrer can be used to ensure more perfect mixing and suspension of the ISO CTD;
- c) temperature regulation device to control the water temperature at that specified for the test;
- d) decontamination filter, installed so as to by-pass the injection loop, which allows the water to be restored to less than 1 200 particles greater than 5 µm per 100 ml;
- e) contaminant injection pump which draws the concentrated contaminant into the recirculation system at a point where the flow is turbulent and discharges it via a flexible pipe into the main pump suction or into the tank of the main circuit. It shall not generate any excessive flow rate pulsation and shall have no effect on the contaminant. The injection flow rate shall be sufficient to prevent segregation of the test dust;
- f) sampling device conforming to ISO 4021;
- g) device for measuring the injection flow rate, insensitive to the contaminant and without effect on its particle size distribution at the concentrations scheduled for the test.

7.1.2.2 Automatic particle counting devices

These devices comprise one or two counters and two optical units.

These devices operate on the principle of the absorption of a beam of white light or of a laser beam or on the laser diffusion principle; they have to be properly calibrated using certified monosized latex spheres.

Ascertain that the high and low detection limits for the device are compatible with the counting thresholds specified in 7.1.4.1.2.1, Table 3.