



Standard Test Method for Sulfur in Liquefied Petroleum Gases (Oxy-Hydrogen Burner or Lamp)¹

This standard is issued under the fixed designation D 2784; the number immediately following the designation indicates the year of original adoption or, in the case of revision, the year of last revision. A number in parentheses indicates the year of last reapproval. A superscript epsilon (ϵ) indicates an editorial change since the last revision or reapproval.

^{e1} NOTE—Warning notes were editorially moved into the standard text in July 2003.

1. Scope

1.1 This test method covers the determination of total sulfur in liquefied petroleum gases containing more than 1 $\mu\text{g/g}$. Specimens should not contain more than 100 $\mu\text{g/g}$ of halogens.

1.2 To attain the quantitative detectability that the method is capable of, stringent techniques must be employed and all possible sources of sulfur contamination must be eliminated. In particular, cleaning agents, such as common household detergents which contain sulfates, should be avoided.

1.3 The values stated in SI units are to be regarded as the standard. The values given in parentheses are for information only.

1.4 *This standard does not purport to address all of the safety concerns, if any, associated with its use. It is the responsibility of the user of this standard to establish appropriate safety and health practices and determine the applicability of regulatory limitations prior to use.*

2. Referenced Documents

2.1 ASTM Standards:

- D 156 Test Method for Saybolt Color of Petroleum Products (Saybolt Chromometer Method)²
- D 1193 Specification for Reagent Water³
- D 1265 Practice for Sampling Liquefied Petroleum (LP) Gases (Manual Method)²
- D 1266 Test Method for Sulfur in Petroleum Products (Lamp Method)²
- D 1657 Test Method for Density or Relative Density of Light Hydrocarbons by Pressure Hydrometer²
- E 11 Specification for Wire Cloth and Sieves for Testing Purposes⁴

¹ This test method is under the jurisdiction of ASTM Committee D02 on Petroleum Products and Lubricants and is the direct responsibility of Subcommittee D02.03 on Elemental Analysis.

Current edition approved May 10, 2003. Published July 2003. Originally approved in 1969. Last previous edition approved in 1998 as D 2784–98.

² *Annual Book of ASTM Standards*, Vol 05.01.

³ *Annual Book of ASTM Standards*, Vol 11.01.

⁴ *Annual Book of ASTM Standards*, Vol 14.02.

2.2 Institute of Petroleum Standard:⁵

IP 181 Sampling Petroleum Gases, Including Liquefied Petroleum Gases

3. Summary of Test Method

3.1 The sample is burned in an oxy-hydrogen burner, or in a lamp in a closed system in a carbon dioxide-oxygen atmosphere. The latter is not recommended for trace quantities of sulfur due to the inordinately long combustion times needed. The oxides of sulfur are absorbed and oxidized to sulfuric acid in a hydrogen peroxide solution. The sulfate ions are then determined by either of the following finishes:

3.1.1 *Barium Perchlorate Titration*—The sulfate is titrated with barium perchlorate using a thiorin-methylene blue mixed indicator.

3.1.2 *Turbidimetric*—The sulfate is precipitated as barium sulfate and the turbidity of a suspension of the precipitate is measured with a photometer.

4. Significance and Use

4.1 It is important to have the sulfur content of liquefied petroleum gases at low enough concentration to meet government regulations. The presence of sulfur can result in corrosion of metal surfaces. Sulfur can be poisonous to catalysts in subsequent processing.

5. Apparatus

5.1 *Oxy-Hydrogen Combustion Assembly*— The two types listed below are recommended. Any combustion apparatus giving equivalent results, however, is satisfactory.

5.1.1 *Wickbold-Type Combustion Apparatus*, as shown in Fig. 1.

5.1.2 *Modified Beckman Burner-Type Apparatus*,^{6,7} as shown in Fig. 2. Each of the above types of apparatus shall

⁵ Available from American National Standards Institute (ANSI), 25 W. 43rd St., 4th Floor, New York, NY 10036.

⁶ The sole source of supply of the apparatus known to the committee at this time is Scientific Glassblowing Co., P.O. Box 18353, Houston, TX 77023.

⁷ If you are aware of alternative suppliers, please provide this information to ASTM International Headquarters. Your comments will receive careful consideration at a meeting of the responsible technical committee⁷, which you may attend.

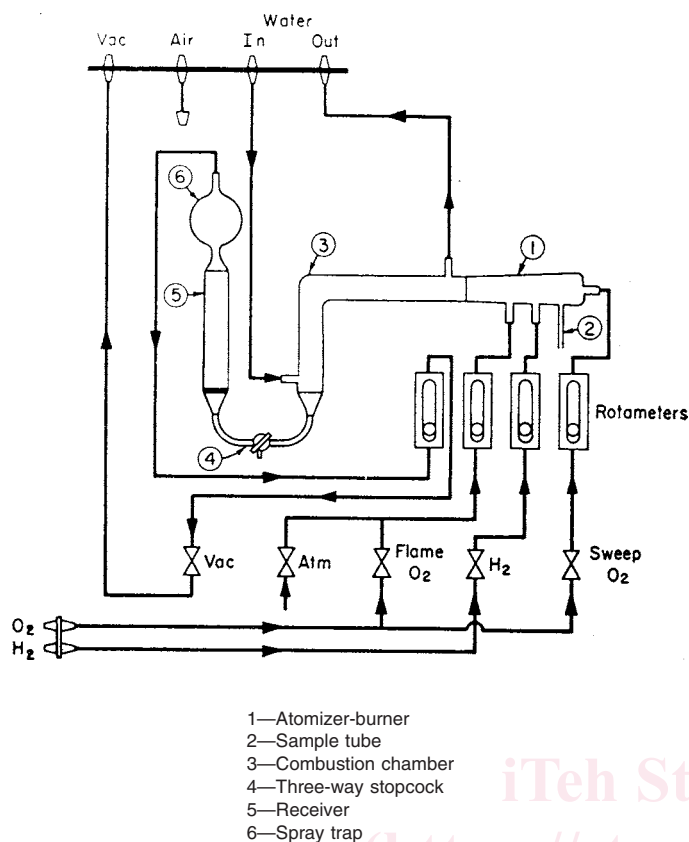

FIG. 1 Flow Diagram of a Typical Oxy-Hydrogen Combustion Apparatus

consist of three parts: atomizer-burner, combustion chamber, and absorber with spray trap. A blowout safety port in the combustion chamber is desirable. The remainder of the apparatus shall consist of a suitable support stand with the necessary needle valves and flow meters for precise control of oxygen, hydrogen, and vacuum.

5.1.3 *Safety Shield*—A transparent shield shall be used to protect the operator in the event an explosive mixture is formed in the combustion chamber.

5.2 *Apparatus for Lamp Combustion:*

5.2.1 *Absorbers, Chimneys, and Spray Traps*, as required are described in detail in Annex A3 of Test Method D 1266.

5.2.2 *Manifold System*, consisting of a vacuum manifold with regulating device, valves, etc. (Fig. 2 of Test Method D 1266) and a dual manifold (burner and chimney) supplying a gas mixture of approximately 70 % carbon dioxide (CO₂) and 30 % oxygen (O₂) at regulated pressures. The gas mixture in the chimney manifold shall be maintained at a nearly constant pressure of 1 to 2 cm of water and the burner manifold at approximately 20 cm of water. A suitable arrangement is shown in Fig. 2 of Test Method D 1266 and described in A3.6 of Annex A3 of Test Method D 1266, but any other similar system giving equivalent results can be used.

5.2.3 *Blast Type Gas Burner*, having dimensions given in Fig. 3.

5.3 *Vacuum Source*, having a capacity of at least 1200 L/h. If a vacuum pump is used, it should be protected by a suitable trap.

5.4 *Corrosion-Resistant Metal Cylinder, 75-mL*—It shall be tested at a pressure of 600 psig (4.14 MPa gage) and shall show no leaks when filled with air or nitrogen to this pressure and submerged in water. It shall be fitted with a needle valve for connection to the burner assembly.

5.5 *Variable Transformer, 0–120 V, 750-W.*

5.6 *Carbon Dioxide Pressure Regulator*— This regulator should be of a type that eliminates the refrigeration difficulties occurring with the pressure reduction of carbon dioxide.^{7,8}

6. Reagents and Materials

6.1 *Purity of Reagents*—Reagent grade chemicals shall be used in all tests. Unless otherwise indicated, it is intended that all reagents shall conform to the specifications of the Committee on Analytical Reagents of the American Chemical Society, where such specifications are available.⁹ Other grades may be used, provided it is first ascertained that the reagent is of sufficiently high purity to permit its use without lessening the accuracy of the determination.

6.2 *Purity of Water*—Unless otherwise indicated, references to water shall be understood to mean reagent water as defined by Types II or III of Specification D 1193. Water conforming to the following specification is required. Sulfate-free deionized water prepared by percolation of water through a column of mixed anion and cation exchange resins.

NOTE 1—A means for determining when to replace the exchange resins should be provided. Use of a simple electrical conductivity meter has been found satisfactory for this purpose.

6.3 *Standard Sulfate Solution (1 mL = 100 µg S)*—Dilute 6.24 ± 0.01 mL of 1 N sulfuric acid (H₂SO₄) with water to exactly 1 L. Check the dilution by titration against standard NaOH solution of about the same normality and adjust the concentration, if necessary, so that each millilitre of this solution is equivalent to 100 µg of sulfur.

6.4 *Hydrogen (Warning—Extremely flammable), Carbon Dioxide (Warning—Gas may reduce oxygen available for breathing), and Oxygen (Warning—Oxygen accelerates combustion)*, meeting the requirement in Note 12.

6.5 *Scavenger-Rinse*—Mix equal volumes of low-sulfur acetone and isopropanol.

6.6 *Hydrogen Peroxide Solution (1.5 %) (1 + 19)* —Mix 1 volume of concentrated hydrogen peroxide (H₂O₂ = 30 %) with 19 volumes of water. Store in a dark-colored, glass-stoppered bottle.

6.7 *Quality Control (QC) Sample(s)*, preferably are portions of one or more liquefied petroleum gas materials or product standards of known sulfur content that were not used in the generation of the instrument calibration curve. These (QC) samples are to be used to check the validity of the testing

⁸ The sole source of supply of the Victor Type SR 300 regulator known to the committee at this time is Victor Equipment Co., Controls Division, 2336 Auburn Blvd., Sacramento, CA 95821.

⁹ *Reagent Chemicals, American Chemical Society Specifications*, American Chemical Society, Washington, DC. For suggestions on the testing of reagents not listed by the American Chemical Society, see *Annual Standards for Laboratory Chemicals*, BDH Ltd., Poole, Dorset, U.K., and the *United States Pharmacopeia and National Formulary*, U.S. Pharmacopeial Convention, Inc. (USPC), Rockville, MD.

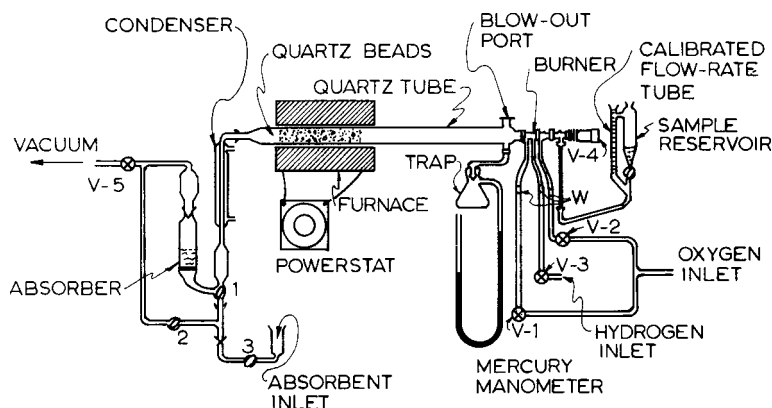
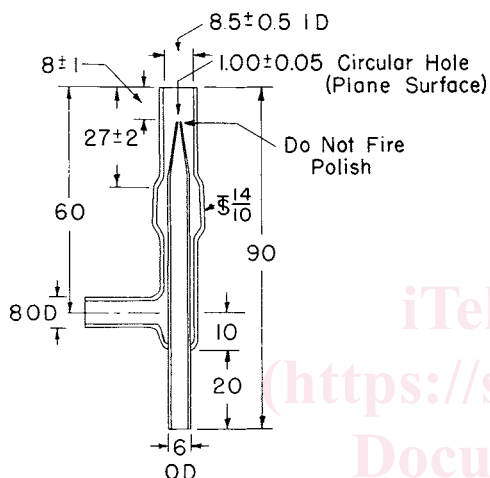

FIG. 2 Trace Sulfur Apparatus Flow Diagram



All dimensions in millimetres

FIG. 3 Blast-Type Gas Burner

NOTE 3—If the weight of liquefied petroleum gas is maintained below 45 g in a 75-mL container, the container cannot become full of liquid at room temperature.

8. Procedure for Combustion of Sample

8.1 Connect the sample cylinder with stainless steel tubing to the gas expansion valve. Attach to this another section of stainless steel tubing which runs to the vicinity of the burner. Make the final connection to the burner with sulfur-free rubber tubing. Wrap the expansion valve with heating tape and connect this to a variable transformer. Insert a thermometer between the heating tape and expansion valve so that the thermometer bulb is in contact with the valve body. See Fig. 4.

8.2 Turn on the variable transformer and allow the expansion valve to reach 43°C (110°F). Alternatively the expansion valve may be placed in a suitable metal beaker and covered with water maintained at 110°F.

8.3 *Oxy-Hydrogen Combustion*—Assemble the apparatus according to the manufacturer's directions (see also 14.1). Add to the absorber 25 mL of the hydrogen peroxide solution. (**Warning**—Before attempting subsequent operations, the operator should (1) be aware of the various hazards that can exist through the improper use of hydrogen as a fuel, and (2) have the safety shield in place.)

8.3.1 Light the burner and insert into the combustion chamber. If necessary, readjust gas flows. Open the bottom valve of the sample cylinder. Slowly open the expansion valve until an optimum burning rate is achieved.

8.4 *Lamp Combustion*—Add to the absorber 25 mL of hydrogen peroxide solution. Assemble the chimney, absorber, and spray trap and connect to the CO₂-O₂ and vacuum manifold. Make the necessary vacuum adjustments (see 5.1 of Test Method D 1266). Set up a control blank absorber as in 5.3 of Test Method D 1266.

8.4.1 Open the bottom valve of the sample cylinder. Slowly crack the gas expansion valve. Light the burner with an alcohol lamp, and insert the burner into the combustion chamber (chimney).

8.5 Burn a quantity of sample in accordance with Table 1.

NOTE 4—In burning materials with sulfur concentrations greater than 50 µg/g, restrict sample sizes to give quantities that will not contain more than 250 µg of sulfur for the turbidimetric finish or more than 150 µg for the barium perchlorate finish. Alternatively, aliquots of the absorber solutions which do not contain more than these maximums can be used.

process as described in Section 16 An ample supply of QC sample material shall be available for the intended period of use, and must be homogeneous and stable under the anticipated storage conditions.

7. Sampling Test Specimens and Test Units

7.1 Obtain the test unit in a container by the method conforming to the recommendations in Practice D 1265, or IP Method 181.

7.2 Evacuate a clean, dry 75-mL cylinder and weigh to the nearest 0.05 g. Connect the container to the inverted supply cylinder and introduce 24 to 40 g of the liquefied gas, taking care that the container does not become full of liquid. To prevent this, bleed off a small amount of the liquid phase of the material after filling but before reweighing. Reweigh the cylinder to 0.05 g.

NOTE 2—The 75-mL, corrosion-resistant metal vessel can be cleaned as follows: Remove the needle valve. Wash the interior of the vessel and valve, first with a sulfur-free hydrocarbon, such as *n*-pentane, and then wash with acetone. Dry the interior of the vessel with clean compressed air and rinse it with HCl (1 + 10). Rinse the interior with water until the wash water is neutral to a pH test paper. Wash the vessel with acetone and allow to drain at least 10 min. Dry the vessel with a stream of clean, compressed air and reassemble.