Immersion suits —

**Part 3:
Test methods**

Combinaisons de protection thermique en cas d'immersion —

Partie 3: Méthodes d'essai

iTeh STANDARD PREVIEW
(standards.iteh.ai)

ISO 15027-3:2002

<https://standards.iteh.ai/catalog/standards/sist/77895518-54ff-43bd-9dd8-ac74ba4677a5/iso-15027-3-2002>



PDF disclaimer

This PDF file may contain embedded typefaces. In accordance with Adobe's licensing policy, this file may be printed or viewed but shall not be edited unless the typefaces which are embedded are licensed to and installed on the computer performing the editing. In downloading this file, parties accept therein the responsibility of not infringing Adobe's licensing policy. The ISO Central Secretariat accepts no liability in this area.

Adobe is a trademark of Adobe Systems Incorporated.

Details of the software products used to create this PDF file can be found in the General Info relative to the file; the PDF-creation parameters were optimized for printing. Every care has been taken to ensure that the file is suitable for use by ISO member bodies. In the unlikely event that a problem relating to it is found, please inform the Central Secretariat at the address given below.

iTeh STANDARD PREVIEW
(standards.iteh.ai)

ISO 15027-3:2002

<https://standards.iteh.ai/catalog/standards/sist/77895518-54ff-43bd-9dd8-ac74ba4677a5/iso-15027-3-2002>

© ISO 2002

All rights reserved. Unless otherwise specified, no part of this publication may be reproduced or utilized in any form or by any means, electronic or mechanical, including photocopying and microfilm, without permission in writing from either ISO at the address below or ISO's member body in the country of the requester.

ISO copyright office
Case postale 56 • CH-1211 Geneva 20
Tel. + 41 22 749 01 11
Fax + 41 22 749 09 47
E-mail copyright@iso.ch
Web www.iso.ch

Printed in Switzerland

Foreword

ISO (the International Organization for Standardization) is a worldwide federation of national standards bodies (ISO member bodies). The work of preparing International Standards is normally carried out through ISO technical committees. Each member body interested in a subject for which a technical committee has been established has the right to be represented on that committee. International organizations, governmental and non-governmental, in liaison with ISO, also take part in the work. ISO collaborates closely with the International Electrotechnical Commission (IEC) on all matters of electrotechnical standardization.

International Standards are drafted in accordance with the rules given in the ISO/IEC Directives, Part 3.

The main task of technical committees is to prepare International Standards. Draft International Standards adopted by the technical committees are circulated to the member bodies for voting. Publication as an International Standard requires approval by at least 75 % of the member bodies casting a vote.

Attention is drawn to the possibility that some of the elements of this part of ISO 15027 may be the subject of patent rights. ISO shall not be held responsible for identifying any or all such patent rights.

ISO 15027-3 was prepared by the European Committee for Standardization (CEN) in collaboration with Technical Committee ISO/TC 188, *Small craft*, in accordance with the Agreement on technical cooperation between ISO and CEN (Vienna Agreement).

Throughout the text of this document, read "this European Standard..." to mean "...this International Standard...".

ISO 15027 consists of the following parts, under the general title *Immersion suits*:

- *Part 1: Constant wear suits, requirements including safety*
- *Part 2: Abandonment suits, requirements including safety*
- *Part 3: Test methods*

Annex A forms a normative part of this part of ISO 15027.

Annex ZZ provides a list of corresponding International and European Standards for which equivalents are not given in the text.

For the purposes of this part of ISO 15027, the CEN annex regarding fulfilment of European Council Directives has been removed.

| Contents | Page |
|--|------|
| Foreword..... | v |
| 1 Scope | 1 |
| 2 Normative references | 1 |
| 3 Testing of the device | 1 |
| 3.1 General..... | 1 |
| 3.2 Sampling..... | 1 |
| 3.3 Test subjects | 1 |
| 3.4 Fuel resistance test | 2 |
| 3.5 Flammability test..... | 2 |
| 3.6 Rotating shock bin testing..... | 4 |
| 3.7 Leakage measurement | 5 |
| 3.8 Thermal test..... | 6 |
| 3.9 Temperature cycling testing | 9 |
| 3.10 Performance testing | 10 |
| 3.11 Ergonomic factors | 10 |
| 3.12 Test method for compressibility of inherently buoyant material..... | 15 |
| 3.13 Test method for thermal stability of inherently buoyant material | 15 |
| Annex A (normative) Test results – Uncertainty of measurement | 16 |
| Annex ZZ (informative) Corresponding International and European Standards for which equivalents are not given in the text..... | 17 |
| Bibliography | 18 |

<https://standards.iteh.ai/catalog/standards/sist/77895518-54ff-43bd-9dd8-ac74ba4677a5/iso-15027-3-2002>

Foreword

This document (EN ISO 15027-3:2002) has been prepared by Technical Committee CEN/TC 162 "Protective clothing including hand and arm protection and lifejackets", the secretariat of which is held by DIN, in collaboration with Technical Committee ISO/TC 188 "Small craft".

This European Standard shall be given the status of a national standard, either by publication of an identical text or by endorsement, at the latest by September 2002, and conflicting national standards shall be withdrawn at the latest by September 2002.

This document has been prepared under a mandate given to CEN by the European Commission and the European Free Trade Association, and supports essential requirements of EU Directive(s).

Annex A is normative.

This standard includes a bibliography.

According to the CEN/CENELEC Internal Regulations, the national standards organizations of the following countries are bound to implement this European Standard : Austria, Belgium, Czech Republic, Denmark, Finland, France, Germany, Greece, Iceland, Ireland, Italy, Luxembourg, Malta, Netherlands, Norway, Portugal, Spain, Sweden, Switzerland and the United Kingdom.

ITEH STANDARD PREVIEW
(standards.iteh.ai)

[ISO 15027-3:2002](https://standards.iteh.ai/catalog/standards/sist/77895518-54ff-43bd-9dd8-ac74ba4677a5/iso-15027-3-2002)

<https://standards.iteh.ai/catalog/standards/sist/77895518-54ff-43bd-9dd8-ac74ba4677a5/iso-15027-3-2002>

iTeh STANDARD PREVIEW
(standards.iteh.ai)

ISO 15027-3:2002

<https://standards.iteh.ai/catalog/standards/sist/77895518-54ff-43bd-9dd8-ac74ba4677a5/iso-15027-3-2002>

1 Scope

This standard specifies the test methods for immersion suits.

This standard is applicable to constant wear suits and abandonment suits.

For requirements for constant wear suits see EN ISO 15027-1 and for requirements for abandonment suits see EN ISO 15027-2.

2 Normative references

This European Standard incorporates by dated or undated reference, provisions from other publications. These normative references are cited at the appropriate places in the text and the publications are listed hereafter. For dated references, subsequent amendments to or revisions of any of these publications apply to this European Standard only when incorporated in it by amendment or revision. For undated references the latest edition of the publication referred to applies (including amendments).

EN ISO 15027-1:2002, *Immersion suits — Part 1: Constant wear suits, requirements including safety (ISO 15027-1:2002)*.

EN ISO 15027-2:2002, *Immersion suits — Part 2: Abandonment suits, requirements including safety (ISO 15027-2:2002)*.

3 Testing of the device

3.1 General

Requirements, for which no special test methods are given in this standard shall be tested in one of the following ways:

- a) by tests referred to in EN ISO 15027-1 and EN ISO 15027-2; or
- b) by measurement; or
- c) by visual assessment; or
- d) by functional test.

Prior to testing materials and components shall be conditioned for $(24 \pm 0,1)$ h under standard atmosphere.

3.2 Sampling

Materials and components common to a range of samples may be presented as one sample of each item to be tested according to test methods given in 4.13 of EN ISO 15027-2:2002, if not specified otherwise by the related test procedure.

3.3 Test subjects

3.3.1 Instruction and selection

All test persons shall be familiar with the test procedures and the use of the suit under test. They shall be informed and instructed on the problematic of the tests. The subjects shall have a medical check-up to prove their qualification for the tests. The tests and a reasonable pre-treatment and follow-up shall be witnessed by a physician. All essential body functions shall be monitored and reported during the tests.

NOTE Attention is drawn to the principles of the Declaration of Helsinki (World Medical Association, 1964) as amended at Edinburgh 2000 and to national rules and regulations such as supervision of the tests by a national ethic commission.

ISO 15027-3:2002(E)

3.3.2 Subject sizes

Where tests call for the use of human subjects at least 6 people shall be used, each wearing a suit of a size category suitable for their build. Their body sizes shall be within the heights and weights shown in Table 1, unless otherwise specified.

Table 1 — Subject sizes

| Height m | Weight kg |
|-------------------|---------------------------------------|
| 1,40 to 1,60 | 1 person under 60 1 person over 60 |
| over 1,60 to 1,80 | 1 person under 70 1 person over 70 |
| over 1,80 | 1 person under 80 1 person over 80 |

3.3.3 Sex of subjects

Not more than $\frac{2}{3}$ of the test subjects shall be of any one sex.

3.3.4 Fitness of subjects

The persons complying with the criteria of 3.3.1 should be capable of relaxing when in water out of their depth, be able to swim for 20 min and cover a distance of 350 m with the aid of a lifejacket approved to a relevant EN and, after sufficient rest, board the platform specified in 3.11.6.2.

3.3.5 Dress of subjects

Throughout the following tests, unless otherwise specified, the test clothing described in 3.8.1.2 shall be worn by each subject.

3.3.6 Pass/fail criteria

All samples shall pass all objective tests for the entire device to meet the requirements of EN ISO 15027-1 or EN ISO 15027-2. However, due to the high variability between subjects and the difficulty in assessing some subjective measures, it is permitted that a device does not completely meet the requirements of the following subjective tests in a single example and in no more than in one test subject. In these circumstances, two other subjects within the same weight category and with the same sex, should be subjected to the same test and before the same test panel as at 3.10.3. If this additional test is still not clearly passed as required in EN ISO 15027-1 or EN ISO 15027-2, then the device shall be deemed to have failed, whilst if it is clearly passed, the test panel may deem that the device has passed the test overall.

3.4 Fuel resistance test

Place representative samples of all exterior fabrics, typical seams, apertures and components in a suitable container and submerge them under a 100 mm head of engine fuel at a temperature of (20 ± 2) °C for 24 h. After removal from the container, remove the surface oil by wiping. Subject the samples to a hydrostatic test with a 1 000 mm water head and a tensile seam strength of at least 150 N without damage.

Note any damage to the fabric or the seams.

3.5 Flammability test

3.5.1 Principle

The test suit is passed over a test pan with burning test fuel. It shall be noted if the suit burns or continues to melt after removal.

3.5.2 Apparatus

Test pan (460 × 350 × 60) mm.

Test fuel: engine fuel.

3.5.3 Sampling

One suit system shall be subjected to the fire test.

3.5.4 Procedure

Place the test pan in a draught-free area so that the suit, which is folded, so that the neck part and feet are even, travels freely across the 578 mm distance of the test pan.

Fill the test pan with water to a depth of 10 mm, followed by enough petrol to make a minimum total depth of 40 mm.

Ignite the petrol and allow to burn freely for 30 s.

Drape the suit over a suitable hanger, folded at the waist with the front outward. The bottom of the suit shall be (250 ± 20) mm from the top edge of the test pan, see Figure 1. Secure loose parts above the lower part of the suit.

Then move the suit with a constant speed through the flames for 2 s. The suit shall start and finish the test 2 m away from the closest edge of the test pan.

3.5.5 Evaluation

It shall be reported whether the suit sustains burning or continues melting 6 s after being removed from the flames.

iTeh STANDARD PREVIEW
(standards.iteh.ai)
ISO 15027-3:2002
<https://standards.iteh.ai/catalog/standards/sist/77895518-54ff-43bd-9dd8-ac74ba4677a5/iso-15027-3-2002>

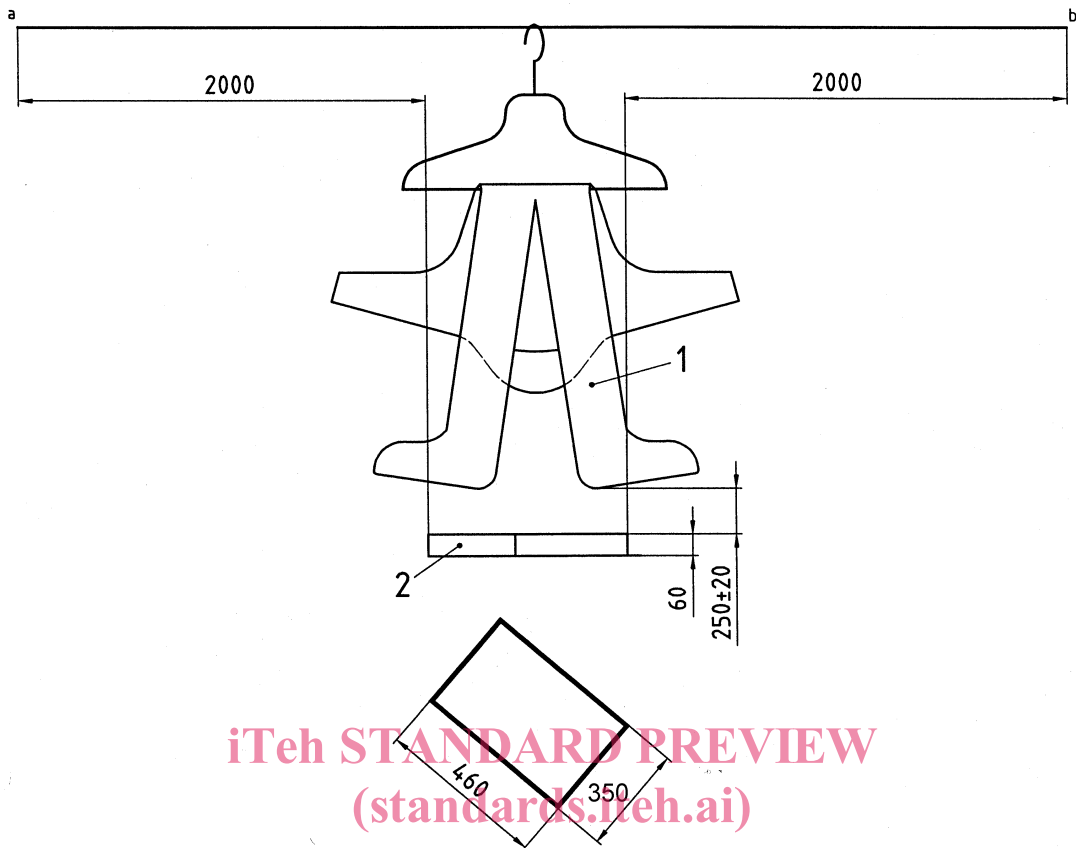

iTeh STANDARD PREVIEW
(standards.iteh.ai)

ISO 15027-3:2002

<https://standards.iteh.ai/catalog/standards/sist/77895518-54ff-43bd-9dd8-ac74ba4677a5/iso-15027-3-2002>

Key

- a Start
- b Finish
- 1 Suit
- 2 Test pan

Figure 1 — Flammability test

3.6 Rotating shock bin testing

3.6.1 Apparatus

The equipment used shall be that shown in Figure 2, consisting of a box of specific design made from plywood board, the inside surface of which shall be coated with hard plastic laminate or similar. The bearing of the bin shall be in the centre of the mass and permit the bin to be rotated freely. This rotation can be effected mechanically, either manually or using a motor.

3.6.2 Procedure

Place the test sample in the bin through a flush panel in one of the bin's faces, then close and secure it. The bin shall be rotated for a total of 150 revolutions at a steady rate of 6 revolutions per minute.

3.6.3 Evaluation

On completion of the rotations, the test sample shall be removed from the bin and examined by the panel for functional integrity.

If any doubts appear further functional testing shall be performed.

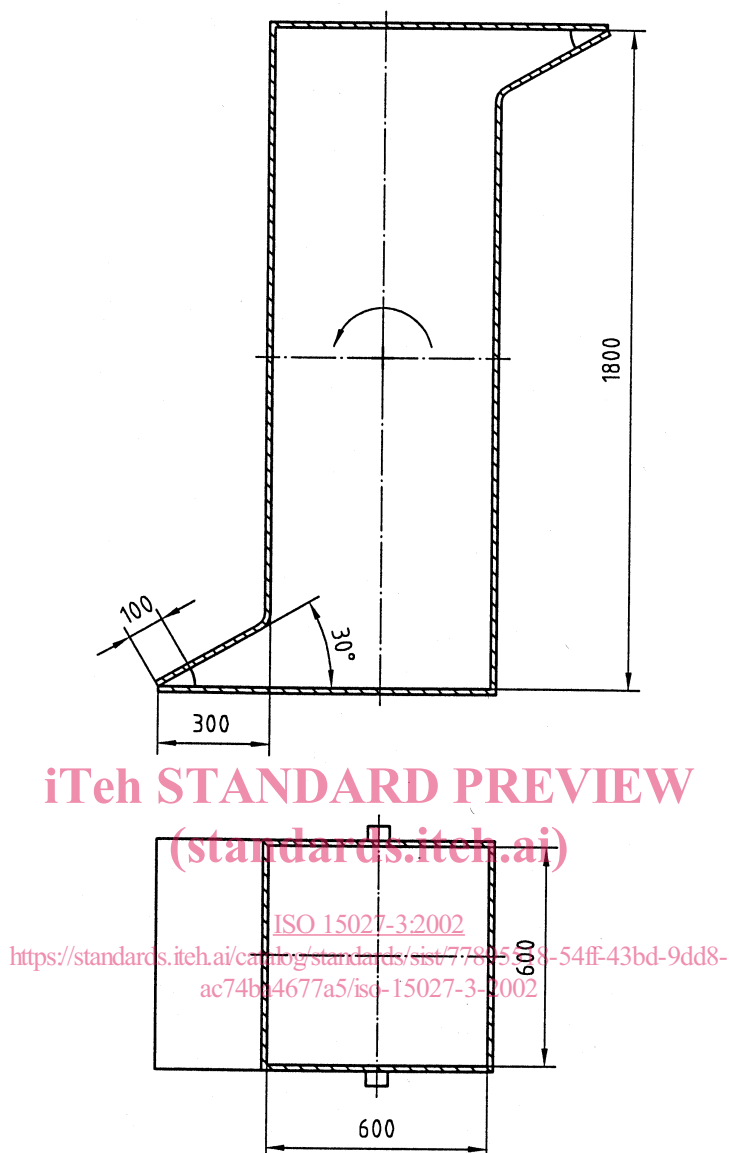

Figure 2 — Design of rotation shock bin apparatus

3.7 Leakage measurement

3.7.1 Clean the suit to condition it prior to leakage measurement and thermal testing. The test sample shall undergo 5 cleaning cycles according to the specification of the manufacturer.

NOTE The amount of leakage will be used as the threshold value for the thermal test.

3.7.2 Each test subject, wearing test clothing, the suit system and a lifejacket if required, shall enter the pool and remain there for 2 min in order to completely pre-wet the suit. Where necessary the suit shall be vented of excess air prior to this test.

3.7.3 The subject shall then climb out and stand for 1 min to permit excess water to run off the exterior of the suit and to remove the water from all trapped areas. The subject shall then be weighed in order to establish the subject's gross weight before the leak tests starts.

3.7.4 Immediately after the "pre-wetting" and weighing, cross one arm over the top of the lifejacket and cover the mouth and nose with the other hand and then jump vertically, feet first, into the pool from a minimum height of $(4,5^{+0,5}_0)$ m. The lifejacket, if needed, shall be inflated prior to this test. The suit shall not be damaged or dislodged in any way by the jump.