**Mechanical vibration — Evaluation of
machine vibration by measurements on
non-rotating parts —**

Part 2:

**Land-based steam turbines and generators
in excess of 50 MW with normal operating
speeds of 1 500 r/min, 1 800 r/min,
3 000 r/min and 3 600 r/min**

[ISO 10816-2:2001](https://standards.iteh.ai/standards/ISO/10816-2:2001)

<https://standards.iteh.ai/standards/ISO/10816-2:2001> *Vibrations mécaniques — Évaluation des vibrations des machines par mesurages sur les parties non tournantes —*

Partie 2: Turbines à vapeur et alternateurs installés sur fondation radier, excédant 50 MW avec des vitesses normales de fonctionnement de 1 500 r/min, 1 800 r/min, 3 000 r/min et 3 600 r/min



PDF disclaimer

This PDF file may contain embedded typefaces. In accordance with Adobe's licensing policy, this file may be printed or viewed but shall not be edited unless the typefaces which are embedded are licensed to and installed on the computer performing the editing. In downloading this file, parties accept therein the responsibility of not infringing Adobe's licensing policy. The ISO Central Secretariat accepts no liability in this area.

Adobe is a trademark of Adobe Systems Incorporated.

Details of the software products used to create this PDF file can be found in the General Info relative to the file; the PDF-creation parameters were optimized for printing. Every care has been taken to ensure that the file is suitable for use by ISO member bodies. In the unlikely event that a problem relating to it is found, please inform the Central Secretariat at the address given below.

iTeh STANDARD PREVIEW
(standards.iteh.ai)

[ISO 10816-2:2001](https://standards.iteh.ai/catalog/standards/sist/129d3ba6-7c13-4bdc-adbf-a9b3c1e0a98c/iso-10816-2-2001)

<https://standards.iteh.ai/catalog/standards/sist/129d3ba6-7c13-4bdc-adbf-a9b3c1e0a98c/iso-10816-2-2001>

© ISO 2001

All rights reserved. Unless otherwise specified, no part of this publication may be reproduced or utilized in any form or by any means, electronic or mechanical, including photocopying and microfilm, without permission in writing from either ISO at the address below or ISO's member body in the country of the requester.

ISO copyright office
Case postale 56 • CH-1211 Geneva 20
Tel. + 41 22 749 01 11
Fax + 41 22 749 09 47
E-mail copyright@iso.ch
Web www.iso.ch

Printed in Switzerland

Foreword

ISO (the International Organization for Standardization) is a worldwide federation of national standards bodies (ISO member bodies). The work of preparing International Standards is normally carried out through ISO technical committees. Each member body interested in a subject for which a technical committee has been established has the right to be represented on that committee. International organizations, governmental and non-governmental, in liaison with ISO, also take part in the work. ISO collaborates closely with the International Electrotechnical Commission (IEC) on all matters of electrotechnical standardization.

International Standards are drafted in accordance with the rules given in the ISO/IEC Directives, Part 3.

Draft International Standards adopted by the technical committees are circulated to the member bodies for voting. Publication as an International Standard requires approval by at least 75 % of the member bodies casting a vote.

Attention is drawn to the possibility that some of the elements of this part of ISO 10816 may be the subject of patent rights. ISO shall not be held responsible for identifying any or all such patent rights.

International Standard ISO 10816-2 was prepared by Technical Committee ISO/TC 108, *Mechanical vibration and shock*, Subcommittee SC 2, *Measurement and evaluation of mechanical vibration and shock as applied to machines, vehicles and structures*.

This second edition cancels and replaces the first edition (ISO 10816-2:1996), which has been technically revised. Criteria for transient operating conditions, such as run up and run down, have been included.

ISO 10816 consists of the following parts, under the general title *Mechanical vibration — Evaluation of machine vibration by measurements on non-rotating parts*: [ISO 10816-2:2001](https://standards.iteh.ai/catalog/standards/sist/129d3ba6-7c13-4bdc-adbf-a9b3c1e0a98c/iso-10816-2-2001)

- *Part 1: General guidelines*
- *Part 2: Land-based steam turbines and generators in excess of 50 MW with normal operating speeds of 1 500 r/min, 1 800 r/min, 3 000 r/min and 3 600 r/min*
- *Part 3: Industrial machines with nominal power above 15 kW and nominal speeds between 120 r/min and 15 000 r/min when measured in situ*
- *Part 4: Gas turbine driven sets excluding aircraft derivatives*
- *Part 5: Machine sets in hydraulic power generating and pumping plants*
- *Part 6: Reciprocating machines with power ratings above 100 kW*

Annex A forms a normative part of this part of ISO 10816. Annex B is for information only.

Introduction

ISO 10816-1 is the basic document which describes the general requirements for measurement and evaluation of the vibration of various machine types when the vibration measurements are made on non-rotating parts. This part of ISO 10816 applies to steam turbines and generators.

Evaluation criteria, based on previous experience, are presented which may be used as guidelines for assessing the vibratory condition of such machines. It must be recognized that these criteria do not form the only basis for judging the severity of vibration. For steam turbines and generators, it is common practice also to judge the vibration based on measurements taken on rotating shafts. Requirements and evaluation criteria for measurements on rotating shafts are addressed in separate standards, ISO 7919-1 and ISO 7919-2.

The evaluation procedures presented in this part of ISO 10816 are based on broad-band measurements. However, it is important to note that because of advances in technology, the use of narrow-band measurements or spectral analysis has become increasingly widespread, particularly for the purposes of vibration evaluation, condition monitoring and diagnostics. The specification of criteria for such measurements is beyond the present scope of this part of ISO 10816. They will be dealt with in ISO 13373-1 for vibration condition monitoring of machines. Further parts of this series are currently under development.

iTeh STANDARD PREVIEW (standards.iteh.ai)

[ISO 10816-2:2001](https://standards.iteh.ai/catalog/standards/sist/129d3ba6-7c13-4bdc-adbf-a9b3c1e0a98c/iso-10816-2-2001)

<https://standards.iteh.ai/catalog/standards/sist/129d3ba6-7c13-4bdc-adbf-a9b3c1e0a98c/iso-10816-2-2001>

Mechanical vibration — Evaluation of machine vibration by measurements on non-rotating parts —

Part 2:

Land-based steam turbines and generators in excess of 50 MW with normal operating speeds of 1 500 r/min, 1 800 r/min, 3 000 r/min and 3 600 r/min

1 Scope

This part of ISO 10816 gives specific guidance for evaluating the severity of vibration measured on the bearings of steam turbines and generators. Guidelines are presented for *in situ*, broad-band vibration measurements taken in the radial direction on the bearings in terms of:

- vibration under normal steady-state operating conditions;
- vibration during transient operation, including passage through resonant speeds during run up or run down;
- changes in vibration which can occur during normal steady-state operation.

The guidelines also apply to axial vibration measured on thrust bearings.

[ISO 10816-2:2001](http://standards.iteh.ai/ISO/10816-2:2001)

This part of ISO 10816 is applicable to land-based steam turbines and generators with a normal operating speed of 1 500 r/min, 1 800 r/min, 3 000 r/min or 3 600 r/min, and power outputs greater than 50 MW. It also includes steam turbines and/or generators which are directly coupled to a gas turbine (such as for combined cycle applications). In such cases the criteria of this part of ISO 10816 apply only to the steam turbine and the generator. Evaluation of the gas turbine vibration should be carried out in accordance with ISO 7919-4 and ISO 10816-4.

2 Normative references

The following normative documents contain provisions which, through reference in this text, constitute provisions of this part of ISO 10816. For dated references, subsequent amendments to, or revisions of, any of these publications do not apply. However, parties to agreements based on this part of ISO 10816 are encouraged to investigate the possibility of applying the most recent editions of the normative documents indicated below. For undated references, the latest edition of the normative document referred to applies. Members of ISO and IEC maintain registers of currently valid International Standards.

ISO 7919-2, *Mechanical vibration — Evaluation of machine vibration by measurements on rotating shafts — Part 2: Land-based steam turbines and generators in excess of 50 MW with normal operating speeds of 1 500 r/min, 1 800 r/min, 3 000 r/min and 3 600 r/min*

ISO 10816-1, *Mechanical vibration — Evaluation of machine vibration by measurements on non-rotating parts — Part 1: General guidelines*

3 Measurement procedures

The measurement procedures to be followed and the instrumentation to be used shall be as described in ISO 10816-1.

The measurement system shall be capable of measuring broad-band vibration over a frequency range from 10 Hz to at least 500 Hz. If, however, the instrumentation is also to be used for diagnostic purposes, or monitoring during machine run up, run down or overspeed, a wider frequency range may be necessary. Furthermore, in special cases where significant low-frequency vibration can be transmitted to the machine (e.g. in earthquake regions), it may be necessary to attenuate the low-frequency response of the instrumentation.

The transducers for vibration measurements shall be mounted on a rigid part of the structure such that they provide adequate sensitivity to the dynamic forces of the machine. Typically, this will require measuring in two orthogonal radial directions on each bearing, as shown in Figure 1. Although the transducers may be placed at any angular location on the bearings, vertical and horizontal directions are usually preferred.

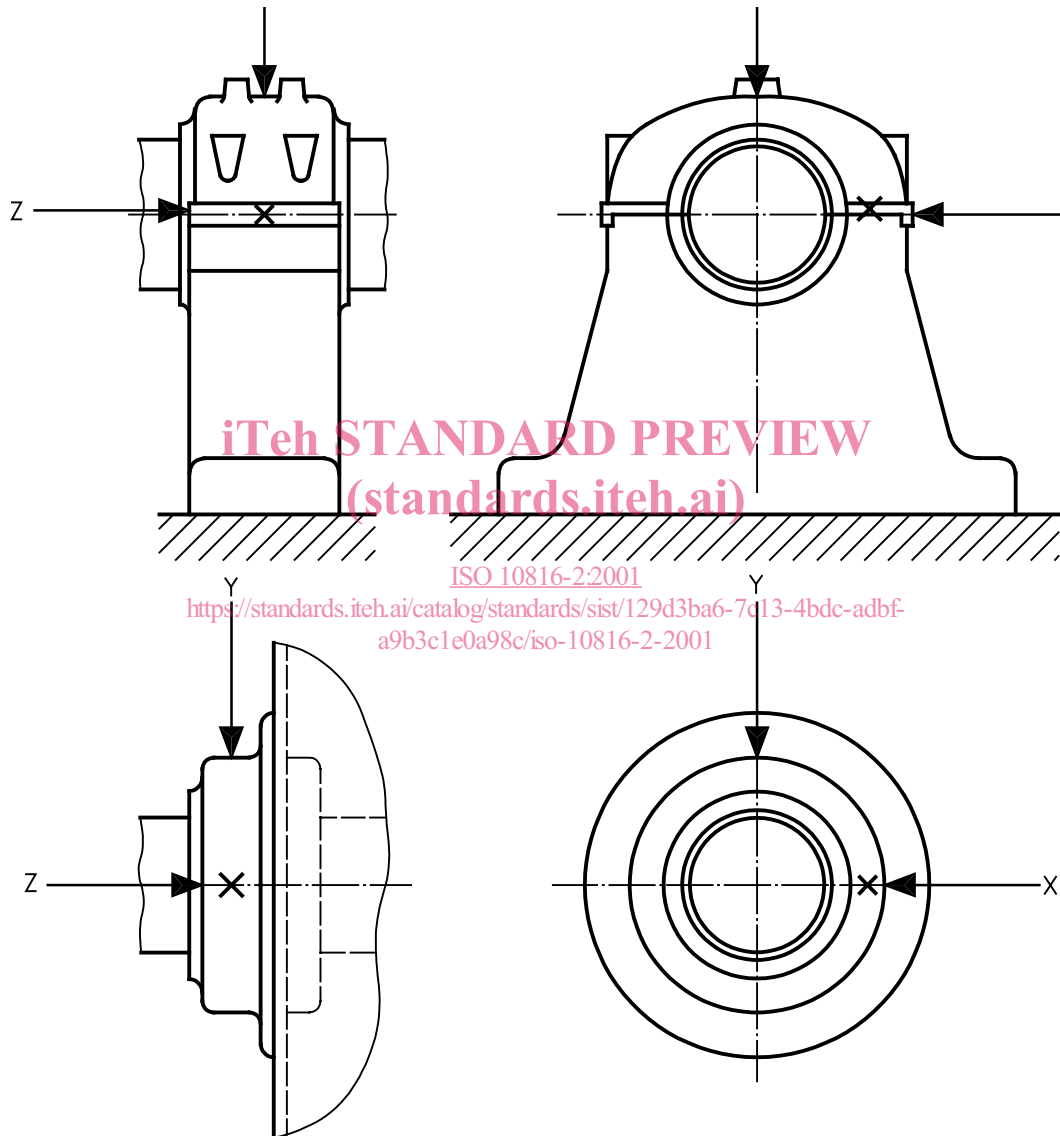

NOTE Evaluation criteria in this part of ISO 10816 apply to radial vibration measurements on all bearings and to axial vibration measurements on thrust bearings.

Figure 1 — Recommended locations of vibration measurements on bearings

A single radial transducer may be used on a bearing in place of the more typical pair of orthogonal transducers if it is known to provide adequate information on the magnitude of the machine vibration. In general, however, caution should be observed in evaluating vibration from a single transducer at a measurement plane since it may not be oriented to provide a reasonable approximation of the maximum value at that plane.

It is not common practice to measure axial vibration on main radial load-carrying bearings of steam turbines and generators for continuous operational monitoring. Such axial measurements are used primarily during periodic vibration surveys, or for diagnostic purposes. Axial vibration criteria are not provided in this part of ISO 10816. However, when axial vibration is measured at thrust bearings, the severity may be judged using the same criteria as for radial vibration.

4 Evaluation criteria

4.1 General

ISO 10816-1 provides a general description of the two evaluation criteria used to assess vibration severity on various classes of machines. One criterion considers the magnitude of observed broad-band vibration; the second considers changes in magnitude, irrespective of whether they are increases or decreases.

Criteria are presented for steady-state operating conditions at the specified rated speed and load ranges, including the normal slow changes in electrical load of the generator. Alternative values of vibration magnitude are also provided for transient operation.

4.2 Criterion I: Vibration magnitude

STANDARD PREVIEW
(standards.iteh.ai)

4.2.1 General

This criterion is concerned with defining limits for absolute vibration magnitude consistent with acceptable dynamic loads on the bearings and acceptable vibration transmission into the support structure and foundation.

4.2.2 Vibration magnitude at rated speed under normal steady-state operating conditions

4.2.2.1 General

The maximum vibration magnitude observed at each bearing or pedestal is assessed against four evaluation zones established from international experience. The maximum magnitude of vibration measured is defined as the vibration severity.

4.2.2.2 Evaluation zones

The following evaluation zones are defined to permit a qualitative assessment of the vibration of a given machine and to provide guidelines on possible actions.

Zone A: The vibration of newly commissioned machines would normally fall within this zone.

Zone B: Machines with vibration within this zone are normally considered acceptable for unrestricted long-term operation.

Zone C: Machines with vibration within this zone are normally considered unsatisfactory for long-term continuous operation. Generally, the machine may be operated for a limited period in this condition until a suitable opportunity arises for remedial action.

Zone D: Vibration values within this zone are normally considered to be of sufficient severity to cause damage to the machine.

NOTE The evaluation zones defined above are relevant to normal steady-state operation at rated speed. Subclause 4.2.4 provides guidelines for transient operation.

4.2.2.3 Evaluation zone boundaries

Recommended values for the zone boundaries are given in annex A. They apply to radial vibration measurements on all bearings and to axial vibration measurements on thrust bearings when taken under steady-state operating conditions at rated speed. The zone boundary values were established from representative data provided by manufacturers and users. Since the data show significant spread, the zone boundary values should be considered only as guidelines. They are not intended to serve as acceptance specifications, which shall be subject to agreement between the machine manufacturer and customer. However, these values provide guidelines for ensuring that gross deficiencies or unrealistic requirements are avoided.

In most cases the values given in Table A.1 are consistent with ensuring that the dynamic loads transmitted to the bearing support structure and foundation are acceptable. However, in certain cases, specific features or available experience associated with a particular machine type may require different zone boundaries to be used (lower or higher). Examples are as follows.

- a) For comparatively lightly loaded bearings (e.g. exciter rotor steady bearings) or other more flexible bearings, other criteria based on the detailed machine design may be necessary.
- b) For some machine designs, where the rotor and bearings are supported on a compliant base/support structure, the magnitudes of (absolute) bearing vibration might be higher than those for steam turbines and generators that have more rigid bearing support structures. It may then be acceptable, based on demonstrated satisfactory operating history, for the zone boundary values given in annex A to be increased.

See also 4.2.3.2 and annex B with regard to setting limits for machines having bearings with different support stiffness.

ITeC STANDARD PREVIEW
(standards.iteh.ai)

In general when higher zone boundary values are used, it might be necessary for technical justification to be provided to confirm that the machine reliability will not be compromised by operating with higher vibration magnitudes. This could be based, for example, on successful operating experience with machines of similar structural design and support. Higher values may also be tolerated during transient conditions, such as run up and run down (see 4.2.4).

This part of ISO 10816 does not provide different evaluation zone values for steam turbines and generators mounted on rigid and flexible foundations. This is consistent with ISO 7919-2 which deals with shaft vibration for the same class of machines. However, this part of ISO 10816 and ISO 7919-2 might be revised in the future to give different criteria for steam turbines and generators mounted on massive concrete foundations and those mounted on lighter, tuned steel foundations, if additional analysis of survey data on such machines shows this to be warranted.

The common measurement parameter for assessing machine vibration severity is velocity. Table A.1 presents the evaluation zone boundaries based on broad-band r.m.s. (root-mean-square) velocity measurements. In many cases, however, it was customary to measure vibration with instruments scaled to read peak rather than r.m.s. vibration velocity values. If the vibration wave form is basically sinusoidal, a simple relationship exists between the peak and r.m.s. values and the zone boundaries of Table A.1 may be readily expressed in peak values.

For steam turbines and generators, it is common for the vibration to be predominantly at the running frequency of the machine. For such cases and when peak rather than r.m.s. values of vibration are being measured, a table equivalent to Table A.1 can be constructed. The zone boundaries of Table A.1 are multiplied by a factor of $\sqrt{2}$ to produce such an equivalent table for assessing peak vibration severity. Alternatively, the measured peak vibration values may be divided by $\sqrt{2}$ and judged against the r.m.s. criteria of Table A.1.

A different factor may be required if instrumentation measuring true peak values is used.

4.2.3 Operational limits for steady-state operation

4.2.3.1 General

For long-term steady-state operation, it is common practice to establish operational vibration limits. These limits take the form of ALARMS and TRIPS.

ALARMS: To provide a warning that a defined value of vibration has been reached or a significant change has occurred, at which remedial action may be necessary. In general, if an ALARM situation occurs, operation can continue for a period whilst investigations are carried out to identify the reason for the change in vibration and define any remedial action.

TRIPS: To specify the magnitude of vibration beyond which further operation of the machine may cause damage. If the TRIP value is exceeded, immediate action should be taken to reduce the vibration or the machine should be shut down.

Different operational limits, reflecting differences in dynamic loading and support stiffness, may be specified for different measurement positions and directions.

4.2.3.2 Setting of ALARMS

The ALARM values may vary for individual machines. The values chosen will normally be set relative to a baseline value determined from experience for the measurement position or direction for that particular machine.

It is recommended that the ALARM value be set higher than the baseline by an amount equal to 25 % of the zone boundary B/C. If the baseline is low, the ALARM may be below zone C (see the example in annex B).

Where there is no established baseline (for example with a new machine) the initial ALARM setting should be based either on experience with other similar machines or relative to agreed acceptance values. After a period of time, the steady-state baseline value will be established and the ALARM setting should be adjusted accordingly.

Where the baseline signal is non-steady and non-repetitive, some method of time averaging of the signal is required. This could be achieved with the aid of a computer.

It is recommended that the ALARM value should not normally exceed 1,25 times the zone boundary B/C.

If the steady-state baseline changes (for example after a machine overhaul), the ALARM setting should be revised accordingly. Different operational ALARM settings may then exist for different bearings on the machine, reflecting differences in dynamic loading and bearing support stiffnesses.

An example of establishing ALARM values is given in annex B.

4.2.3.3 Setting of TRIPS

The TRIP values will generally relate to the mechanical integrity of the machine and be dependent on any specific design features which have been introduced to enable the machine to withstand abnormal dynamic forces. The values used will, therefore, generally be the same for all machines of similar design and would not normally be related to the steady-state baseline value used for setting ALARMS.

There may, however, be differences for machines of different design and it is not possible to give more precise guidelines for absolute TRIP values. In general, the TRIP value will be within zone C or D, but it is recommended that the TRIP value should not exceed 1,25 times the zone boundary C/D.