



**SLOVENSKI STANDARD**  
**SIST EN 14516:2006+A1:2010**  
**01-oktober-2010**

---

**Kopalne kadi za domačo uporabo**

Baths for domestic purposes

Badewannen für den Hausgebrauch

Baignoires à usage domestique

**Ta slovenski standard je istoveten z: EN 14516:2006+A1:2010**

**ITEH STANDARD PREVIEW**  
**(standards.iteh.ai)**  
[SIST EN 14516:2006+A1:2010](https://standards.iteh.ai/catalog/standards/sist/dcf903a-7cda-4ecc-9c3f-bbb7d708f42e/sist-en-14516-2006a1-2010)  
<https://standards.iteh.ai/catalog/standards/sist/dcf903a-7cda-4ecc-9c3f-bbb7d708f42e/sist-en-14516-2006a1-2010>

**ICS:**

91.140.70      Sanitarne naprave      Sanitary installations

**SIST EN 14516:2006+A1:2010**      **en,fr,de**

**iTeh STANDARD PREVIEW**  
**(standards.iteh.ai)**

SIST EN 14516:2006+A1:2010

<https://standards.iteh.ai/catalog/standards/sist/dcf903a-7cda-4eec-9c3f-bbb7d708f42e/sist-en-14516-2006a1-2010>

EUROPEAN STANDARD  
NORME EUROPÉENNE  
EUROPÄISCHE NORM

**EN 14516:2006+A1**

July 2010

ICS 91.140.70

Supersedes EN 14516:2006

English Version

## Baths for domestic purposes

Baignoires à usage domestique

Badewannen für den Hausgebrauch

This European Standard was approved by CEN on 14 December 2005 and includes Amendment 1 approved by CEN on 19 June 2010.

CEN members are bound to comply with the CEN/CENELEC Internal Regulations which stipulate the conditions for giving this European Standard the status of a national standard without any alteration. Up-to-date lists and bibliographical references concerning such national standards may be obtained on application to the CEN Management Centre or to any CEN member.

This European Standard exists in three official versions (English, French, German). A version in any other language made by translation under the responsibility of a CEN member into its own language and notified to the CEN Management Centre has the same status as the official versions.

CEN members are the national standards bodies of Austria, Belgium, Bulgaria, Croatia, Cyprus, Czech Republic, Denmark, Estonia, Finland, France, Germany, Greece, Hungary, Iceland, Ireland, Italy, Latvia, Lithuania, Luxembourg, Malta, Netherlands, Norway, Poland, Portugal, Romania, Slovakia, Slovenia, Spain, Sweden, Switzerland and United Kingdom.

(standards.iteh.ai)

[SIST EN 14516:2006+A1:2010](https://standards.iteh.ai/catalog/standards/sist/dcf903a-7cda-4ecc-9c3f-bbb7d708f42e/sist-en-14516-2006a1-2010)

<https://standards.iteh.ai/catalog/standards/sist/dcf903a-7cda-4ecc-9c3f-bbb7d708f42e/sist-en-14516-2006a1-2010>



EUROPEAN COMMITTEE FOR STANDARDIZATION  
COMITÉ EUROPÉEN DE NORMALISATION  
EUROPÄISCHES KOMITEE FÜR NORMUNG

Management Centre: Avenue Marnix 17, B-1000 Brussels

## Contents

	page
Foreword.....	3
1 Scope .....	4
2 Normative references .....	4
3 Terms and definitions .....	4
4 Classification.....	5
5 <b>A1</b> Requirements for class 1 products <b>A1</b> .....	5
5.1 General.....	5
5.2 Cleanability.....	5
5.3 <b>A1</b> Durability <b>A1</b> .....	5
6 Requirements for class 2 products.....	6
7 Dangerous substances .....	7
8 Test methods.....	7
8.1 Stability of the bottom of the bath .....	7
8.2 Resistance to chemicals and staining agents .....	8
8.3 Resistance to temperature changes .....	10
9 Marking, labelling and packaging .....	11
10 Evaluation of conformity.....	12
10.1 General.....	12
10.2 Type testing.....	12
10.3 Factory production control.....	13
Annex A (informative) Materials.....	15
Annex B (informative) Surfaces of baths .....	17
Annex ZA (informative) <b>A1</b> Clauses of this European Standard addressing the provisions of the EU Construction Products Directive <b>A1</b> .....	18
Bibliography .....	23

## Foreword

This document (EN 14516:2006+A1:2010) has been prepared by Technical Committee CEN/TC 163 “Sanitary appliances”, the secretariat of which is held by UNI.

This European Standard shall be given the status of a national standard, either by publication of an identical text or by endorsement, at the latest by January 2011, and conflicting national standards shall be withdrawn at the latest by April 2012.

Attention is drawn to the possibility that some of the elements of this document may be the subject of patent rights. CEN [and/or CENELEC] shall not be held responsible for identifying any or all such patent rights.

This document includes Amendment 1, approved by CEN on 2010-06-19.

This document supersedes EN 14516:2006.

The start and finish of text introduced or altered by amendment is indicated in the text by tags  $\boxed{A_1}$   $\boxed{A_1}$ .

$\boxed{A_1}$  This document has been prepared under a mandate given to CEN by the European Commission and the European Free Trade Association and supports essential requirements of EU Directive(s).  $\boxed{A_1}$

For relationship with EU Directive(s), see informative Annex ZA, which is an integral part of this document.

According to the CEN/CENELEC Internal Regulations, the national standards organizations of the following countries are bound to implement this European Standard: Austria, Belgium, Bulgaria, Croatia, Cyprus, Czech Republic, Denmark, Estonia, Finland, France, Germany, Greece, Hungary, Iceland, Ireland, Italy, Latvia, Lithuania, Luxembourg, Malta, Netherlands, Norway, Poland, Portugal, Romania, Slovakia, Slovenia, Spain, Sweden, Switzerland and United Kingdom.

**EN 14516:2006+A1:2010 (E)****1 Scope**

This document specifies requirements, test methods and procedures for evaluation of conformity for baths used for domestic purposes and personal hygiene, which ensure that the product, when installed and maintained in accordance with the manufacturer's instructions, will satisfy requirements for  $\text{A}_1$  cleanability and durability  $\text{A}_1$ .

This document is applicable to all sizes and shapes of baths.

This document does not cover baths for use with medical provisions.

NOTE 1 For the purpose of this standard the term "domestic purposes" includes use in hotels, accommodation for students, hospitals and similar buildings.

NOTE 2 Annex A lists characteristics of materials commonly used for manufacturing baths.

**2 Normative references**

The following referenced documents are indispensable for the application of this document. For dated references, only the edition cited applies. For undated references, the latest edition of the referenced document (including any amendments) applies.

EN 232, *Baths — Connecting dimensions*

EN ISO 8290, *Vitreous and porcelain enamels — Determination of resistance to sulphuric acid at room temperature (ISO 8290:1998)*

ISO 2722, *Vitreous and porcelain enamels — Determination of resistance to citric acid at room temperature*  
SIST EN 14516:2006+A1:2010

ISO 2742, *Vitreous and porcelain enamels — Determination of resistance to boiling citric acid*  
<http://enr.iteh.ai/enr/standards/sist-en-14516-2006a1-2010/bbb7d708f42e/sist-en-14516-2006a1-2010>

ISO 2744, *Vitreous and porcelain enamels — Determination of resistance to boiling water and water vapour*

ISO 4533, *Vitreous and porcelain enamels — Determination of resistance to hot detergent solutions used for washing textiles*

**3 Terms and definitions**

For the purposes of this document, the following terms and definitions apply.

**3.1****bath**

sanitary appliance used for partial immersion and washing of the human body or parts of it, and for directing water to a waste outlet after use

**3.2****cleanability**

characteristics which allow the surface intended to come into contact with water to be non-absorbent and readily kept visually free from dirt and/or stains when subject to a maintenance regime which may include, when appropriate, specific instructions for use and care specified by the manufacturer

$\text{A}_1$

**3.3****durability**

attributes of materials and their surfaces intended to come into contact with water, which allow the anticipated working life of the product  $\text{A}_1$

Ⓐ

## 4 Classification

Class 1: Products complying with the requirements of Clause 5

Class 2: Products complying with the requirements of Clause 6 Ⓐ

Ⓐ

## 5 Requirements for class 1 products Ⓐ

### 5.1 General

The manufacturer shall provide instructions with each bath covering installation and care.

NOTE Annex B gives advice which manufacturers can include in their instructions.

### 5.2 Cleanability

#### 5.2.1 Appearance of surface

When a bath is inspected under strong and oblique illumination, the surfaces intended to come into contact with water shall be visibly smooth, non-absorbent and free from inaccessible corners that would impair the cleanability.

NOTE Surfaces with cracks, chips, crazing and other similar defects are not considered to be smooth.

#### 5.2.2 Drainage of water

<https://standards.iteh.ai/catalog/standards/sist/dcf903a-7cda-4ecc-9c3f-bbb7d708f42e/sist-en-14516-2006a1-2010>

Baths shall have at least one waste outlet hole. The dimensions of the waste outlet hole shall comply with the requirements of EN 232. Other dimensions are permissible, if the manufacturer provides or recommends a suitable waste fitting.

All water shall empty from the bath unless prevented by surface tension.

Ⓐ

### 5.3 Durability Ⓐ

#### 5.3.1 General

Conformance with the requirements of Ⓐ 5.3.2 to 5.3.4 Ⓐ give an assurance of durability Ⓐ *deleted text* Ⓐ.

#### 5.3.2 Stability of bottom

When tested in accordance with Ⓐ 8.1 Ⓐ, there shall be no permanent distortion or other defects, e.g. cracks, such that the requirements of Ⓐ 5.2.2 Ⓐ are not satisfied.

#### 5.3.3 Resistance to chemicals and staining agents

##### 5.3.3.1 General

When baths, other than those made from the materials specified in Ⓐ 5.3.3.2 Ⓐ, are tested in accordance with Ⓐ 8.2 Ⓐ, the surface finish shall be unaffected by the chemicals and staining agents specified in Table 1, except for superficial surface changes which are removable with water or with water and the specified abrasive agent.

## EN 14516:2006+A1:2010 (E)

Table 1 — Chemicals and staining agents

Family	Product
Acids	Acetic acid (CH <sub>3</sub> COOH), 10 % V/V
Alkalines	Sodium hydroxide (NaOH), 5 % m/m
Alcohols	Ethanol (C <sub>2</sub> H <sub>5</sub> OH), 70 % V/V
Bleaches	Sodium hypochlorite (NaOCl), 5 % active chlorine (Cl <sub>2</sub> ) <sup>a</sup>
Staining agents	Methylene blue, 1 % m/m

<sup>a</sup> The specified bleach may be replaced by sodium percarbonate (2Na<sub>2</sub>CO<sub>3</sub> · 3H<sub>2</sub>O<sub>2</sub>) prepared as follows: Dissolve 1g of a commercial available powdery bleach based on sodium percarbonate containing 15 % to 30 % of the active component in 100 ml deionised water at room temperature.

## 5.3.3.2 Particular requirements for baths made of enamelled steel and enamelled cast iron

Baths made from enamelled steel and enamelled cast iron shall comply with the requirements given in Table 2.

Table 2 — Requirements for baths made of enamelled steel and enamelled cast iron

Requirement	Parameter	Test method
Resistance to boiling water	< 10g/m <sup>2</sup>	ISO 2744
Resistance to cold citric acid	Class 2	ISO 2722
Resistance to boiling citric acid	< 5g/m <sup>2</sup>	ISO 2742
Resistance to cold sulphuric acid	Class 2	EN ISO 8290
Resistance to alkali solutions	< 8 g/m <sup>2</sup>	Test apparatus according to ISO 2742 Test solution according to ISO 4533 Duration of test: 2,5 h

## 5.3.4 Resistance to temperature changes

When tested in accordance with **A1** 8.3 **A1**, all baths shall show no evidence of distortion or other defects, e.g. crazing, which will impair their cleanability.

Experience has shown that baths manufactured from the stainless steel grades listed in Annex A, enamelled steel, enamelled cast iron and glazed ceramics comply with this requirement.

**A1** *deleted text* **A1**

**A1**

## 6 Requirements for class 2 products

## 6.1 General

The manufacturer shall provide instructions with each bath covering installation and care.

NOTE Annex B gives advice which manufacturers can include in their instructions.



## 6.2 Cleanability

### 6.2.1 Appearance of surface

When a bath is inspected under strong and oblique illumination, the surfaces intended to come into contact with water shall be visibly smooth, non-absorbent and free from inaccessible corners that would impair the cleanability.

NOTE Surfaces with cracks, chips, crazing and other similar defects are not considered to be smooth.

### 6.2.2 Drainage of water

Baths shall have at least one waste outlet hole. The dimensions of the waste outlet hole shall comply with the requirements of EN 232. Other dimensions are permissible, if the manufacturer provides or recommends a suitable waste fitting.

All water shall empty from the bath unless prevented by surface tension.

## 6.3 Durability

### 6.3.1 General

Baths shall be readily cleanable for their anticipated working life when normal cleaning and maintenance is carried out.

### 6.3.2 Materials

Experience has shown that baths made from plastics materials, enamelled steel, enamelled cast iron, stainless steel, glazed ceramics or glass and their surfaces intended to come into contact with water have the properties described in 6.3.1. <sup>A1</sup>

**iTeh STANDARD PREVIEW**  
(standards.iteh.ai)

<https://standards.iteh.ai/catalog/standards/sist/dcf903a-7cda-4ecc-9c3f-bbb7d708f42e/sist-en-14516-2006a1-2010>

<sup>A1</sup>

## 7 Dangerous substances

NOTE See Annex ZA, ZA.1 and ZA.3. <sup>A1</sup>

## 8 Test methods

### 8.1 Stability of the bottom of the bath

#### 8.1.1 Test apparatus

— adequate number of reinforced cloth bags each with dimensions of approximately 500 mm x 200 mm filled with lead shot, iron shot or sand of a mass of  $25^{+0,5}_0$  kg or  $12,5^{+0,5}_0$  kg.

#### 8.1.2 Determination of the load

The load to be applied for the test shall comprise:

- adequate number of cloth bags (see <sup>A1</sup> 8.1.1 <sup>A1</sup>) equating to 100 kg for each user intended to use the bath at the same time;
- adequate number of cloth bags (see <sup>A1</sup> 8.1.1 <sup>A1</sup>) to simulate the mass of water that can be contained in the bath.

**EN 14516:2006+A1:2010 (E)**

The load shall equate to the volume of water with an accuracy of  ${}_{0}^{+25}$  kg, if 25 kg bags are used, or  ${}_{0}^{+12,5}$  kg, if 12,5 kg bags are used, when the bath is filled to the overflow. If no overflow is provided the volume to the overspill level shall be used. The volume can be determined by measurement, or values declared in the manufacturer's literature can be used.

**8.1.3 Procedure**

- Install the bath in accordance with the manufacturer's installation instructions.
- Position the bags to simulate the mass of water that can be contained along the bottom of the bath as shown in Figure 1.
- Position the adequate number of bags for each user that can use the bath at the same time in separate piles, as shown in Figure 1.



**Figure 1 – Load application (for each user)**

- Leave the total load for  $10 {}_{0}^{+1}$  min.
- Without moving the bags representing the mass of water that can be contained, move the pile(s) of bags representing a user(s) to a different position(s) along the bottom of the bath and leave again for  $10 {}_{0}^{+1}$  min. When a bath has a clearly indicated position for a user to stand or to sit, e.g. a slip resistant feature or a seating area, carry out one loading test with a pile of bags representing a user, at the approximate centre of any such feature.
- On completion of the tests remove all the bags.
- After  $10 {}_{0}^{+1}$  min verify that the bath complies with  $\text{A}_1$  5.3.2  $\text{A}_1$  by pouring copious amounts of water coloured in contrast with the colour of the bath around all the inner surface of the sides of the bathing area.

**8.2 Resistance to chemicals and staining agents****8.2.1 Principle**

The test is intended to give an indication of the effect of commonly used household chemicals and cleansing agents.

**8.2.2 Test apparatus and chemicals**

- a) chemicals and staining agents

A list of chemicals and staining agents to be used is specified in Table 1. Each chemical solution shall be prepared immediately before use with deionised water, and it shall be applied at a temperature  $(23 \pm 5)$  °C.

- b) borosilicate watch glasses: 40 mm nominal diameter;
- c) pipettes;

d) cleaning device;

A typical cleaning device is shown in Figure 2. It consists of a disc of 75 mm diameter, faced with synthetic flexible open cell foam 15 mm in thickness. The device is driven by means of a square axle which fits loosely into the device. Any device having a mass of  $(1\ 000 \pm 50)$  g can be used.

e) abrasive comprising 12 h-alumina (suspension of aluminium oxide in water)<sup>1)</sup>.

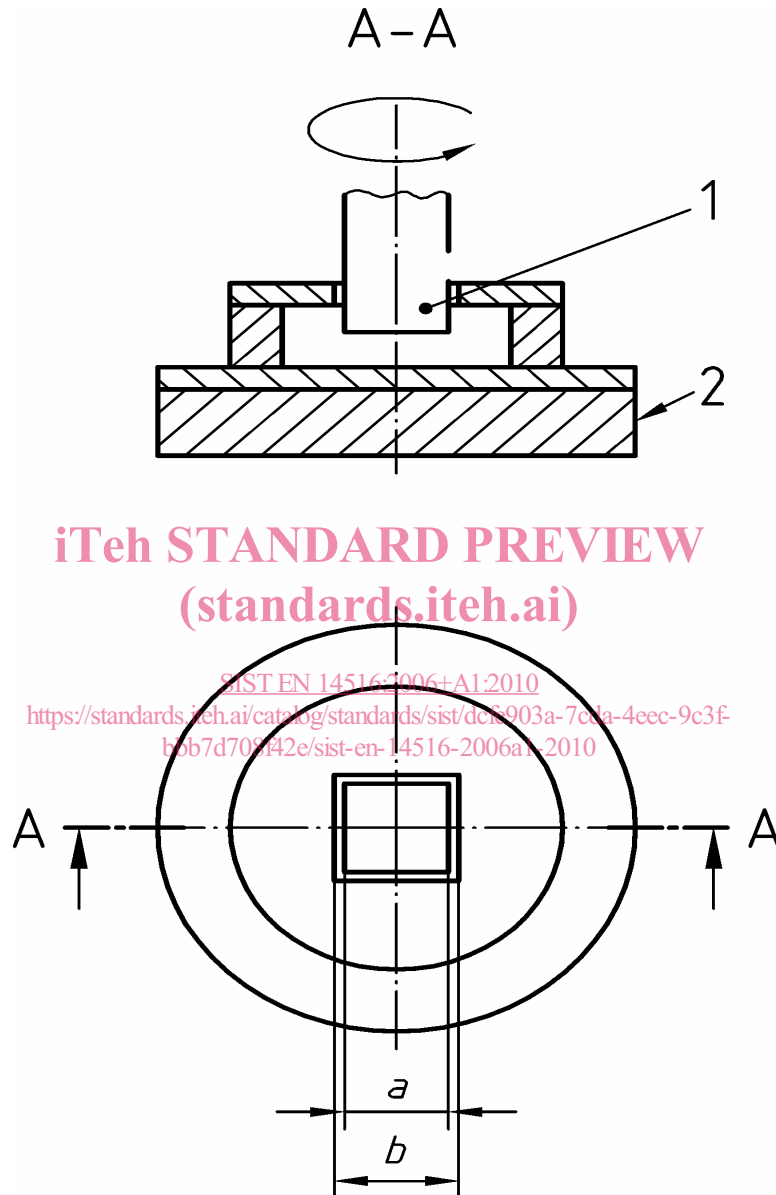

**Key**

- 1 square axle ( $a = b - 1$  mm)  
2 disc faced with foam

**Figure 2 — Cleaning device**

### 8.2.3 Test specimens

Carry out the tests on the bottom, and on a flat part of the wall of the bath or on test specimens cut from these areas.

1) A suitable product is available from MERCK Eurolab-Prolabo, 54 rue Roger Salengro, 94126 Fontenay sous Bois CEDEX, France, as DURMAX™ under product description N° 20993. This information is given for the convenience of users of this standard and does not constitute an endorsement by CEN of these products.