



SLOVENSKI STANDARD
SIST-TS CEN/TS 15405:2010
01-november-2010

Nadomešča:
SIST-TS CEN/TS 15405:2007

Trdna alternativna goriva - Določevanje gostote peletov in briketov

Solid recovered fuels - Determination of density of pellets and briquettes

Feste Sekundärbrennstoffe - Bestimmung der Dichte von Pellets und Briketts

Combustibles solides de récupération - Méthode de détermination de la densité des
granulés et des briquettes **(standards.iteh.ai)**

Ta slovenski standard je istoveten z: CEN/TS 15405:2010
SIST-TS CEN/TS 15405:2010
http://standards.iteh.ai/catalog/standards/cen/ts/15405-2010
da8fed6a0549/sist-ts-cen-ts-15405-2010

ICS:

75.160.10	Trda goriva	Solid fuels
-----------	-------------	-------------

SIST-TS CEN/TS 15405:2010 en,de

iTeh STANDARD PREVIEW
(standards.iteh.ai)

[SIST-TS CEN/TS 15405:2010](https://standards.iteh.ai/catalog/standards/sist/9bd1189a-050d-4045-8f11-da8fed6a0549/sist-ts-cen-ts-15405-2010)

<https://standards.iteh.ai/catalog/standards/sist/9bd1189a-050d-4045-8f11-da8fed6a0549/sist-ts-cen-ts-15405-2010>

TECHNICAL SPECIFICATION
SPÉCIFICATION TECHNIQUE
TECHNISCHE SPEZIFIKATION

CEN/TS 15405

September 2010

ICS 75.160.10

Supersedes CEN/TS 15405:2006

English Version

**Solid recovered fuels - Determination of density of pellets and
briquettes**

Combustibles solides de récupération - Méthode de
détermination de la densité des granulés et des briquettes

Feste Sekundärbrennstoffe - Bestimmung der Dichte von
Pellets und Briquettes

This Technical Specification (CEN/TS) was approved by CEN on 12 June 2010 for provisional application.

The period of validity of this CEN/TS is limited initially to three years. After two years the members of CEN will be requested to submit their comments, particularly on the question whether the CEN/TS can be converted into a European Standard.

CEN members are required to announce the existence of this CEN/TS in the same way as for an EN and to make the CEN/TS available promptly at national level in an appropriate form. It is permissible to keep conflicting national standards in force (in parallel to the CEN/TS) until the final decision about the possible conversion of the CEN/TS into an EN is reached.

CEN members are the national standards bodies of Austria, Belgium, Bulgaria, Croatia, Cyprus, Czech Republic, Denmark, Estonia, Finland, France, Germany, Greece, Hungary, Iceland, Ireland, Italy, Latvia, Lithuania, Luxembourg, Malta, Netherlands, Norway, Poland, Portugal, Romania, Slovakia, Slovenia, Spain, Sweden, Switzerland and United Kingdom.

[SIST-TS CEN/TS 15405:2010](https://standards.iteh.ai/catalog/standards/sist/9bd1189a-050d-4045-8f11-da8fed6a0549/sist-ts-cen-ts-15405-2010)

<https://standards.iteh.ai/catalog/standards/sist/9bd1189a-050d-4045-8f11-da8fed6a0549/sist-ts-cen-ts-15405-2010>



EUROPEAN COMMITTEE FOR STANDARDIZATION
COMITÉ EUROPÉEN DE NORMALISATION
EUROPÄISCHES KOMITEE FÜR NORMUNG

Management Centre: Avenue Marnix 17, B-1000 Brussels

Contents

	Page
Foreword.....	3
Introduction	4
1 Scope	5
2 Normative references	5
3 Terms and definitions	5
4 Principle	5
5 Apparatus	6
6 Sampling and sample preparation	8
7 Procedure	8
8 Calculation.....	9
9 Precision.....	10
10 Test report	10
Annex A (informative) Correction values for the density of water as a function of temperature	11
Annex B (informative) Volume determination of regularly shaped briquettes by stereometry.....	12
Bibliography	14

[SIST-TS CEN/TS 15405:2010](https://standards.iteh.ai/catalog/standards/sist/9bd1189a-050d-4045-8f11-da8fed6a0549/sist-ts-cen-ts-15405-2010)
<https://standards.iteh.ai/catalog/standards/sist/9bd1189a-050d-4045-8f11-da8fed6a0549/sist-ts-cen-ts-15405-2010>

Foreword

This document (CEN/TS 15405:2010) has been prepared by Technical Committee CEN/TC 343 “Solid recovered fuels”, the secretariat of which is held by SFS.

Attention is drawn to the possibility that some of the elements of this document may be the subject of patent rights. CEN [and/or CENELEC] shall not be held responsible for identifying any or all such patent rights.

This document supersedes CEN/TS 15405:2006.

CEN/TS 15405:2006 is not to be converted into a European Standard as the test method specified in this document was not validated (see [1], [2]).

This document differs from CEN/TS 15405:2006 mainly as follows:

- a) number of replicate tests changed to two replications;
- b) whole document editorially revised.

According to the CEN/CENELEC Internal Regulations, the national standards organizations of the following countries are bound to announce this Technical Specification: Austria, Belgium, Bulgaria, Croatia, Cyprus, Czech Republic, Denmark, Estonia, Finland, France, Germany, Greece, Hungary, Iceland, Ireland, Italy, Latvia, Lithuania, Luxembourg, Malta, Netherlands, Norway, Poland, Portugal, Romania, Slovakia, Slovenia, Spain, Sweden, Switzerland and the United Kingdom.

[SIST-TS CEN/TS 15405:2010](https://standards.iteh.ai/catalog/standards/sist/9bd1189a-050d-4045-8f11-da8fed6a0549/sist-ts-cen-ts-15405-2010)

<https://standards.iteh.ai/catalog/standards/sist/9bd1189a-050d-4045-8f11-da8fed6a0549/sist-ts-cen-ts-15405-2010>

CEN/TS 15405:2010 (E)**Introduction**

This Technical Specification specifies a method for the determination of particle density where the required volume is measured by the buoyancy in a liquid. The parameter particle density is not an absolute value, therefore conditions for its determination should be standardised in order to gain comparative measuring results. Practical experience shows that for briquettes, the method specified is also replaceable by a similar measurement applying a gravimetric determination of the volume via the displaced liquid. In this case, the container with the liquid is not positioned underneath the balance as specified in this Technical Specification but is placed onto the balance which would then have to carry a higher total mass (at the same accuracy requirements). For all other requirements (e.g. for the wetting agent), the procedure as outlined in this Technical Specification should be followed, except, that the Equation for density calculation shall be modified accordingly.

This Technical Specification is based on CEN/TS 15150.

**iTeh STANDARD PREVIEW
(standards.iteh.ai)**

SIST-TS CEN/TS 15405:2010

<https://standards.iteh.ai/catalog/standards/sist/9bd1189a-050d-4045-8f11-da8fed6a0549/sist-ts-cen-ts-15405-2010>

1 Scope

This Technical Specification specifies a method for the determination of particle density of irregularly shaped pieces of compressed fuels such as pellets or briquettes. It is not applicable to soft or semi-soft pellets.

NOTE 1 The term soft pellet is defined in CEN/TS 15639.

NOTE 2 Particle density is subject to variation due to the susceptibility of organic material to environmental or technical impacts such as air humidity, vibration, abrasion or biodegradation. Therefore, particle density can vary during time thus the measured values should be regarded as a momentary fuel property.

NOTE 3 At the time of preparing this document, the production of briquettes of solid recovered fuels could not be identified in the European market.

2 Normative references

The following referenced documents are indispensable for the application of this Technical Specification. For dated references, only the edition cited applies. For undated references, the latest edition of the referenced document (including any amendments) applies.

prEN 15357:2008, *Solid recovered fuels — Terminology, definitions and descriptions*

prEN 15442, *Solid recovered fuels — Methods for sampling*

prEN 15443, *Solid recovered fuels — Methods for the preparation of the laboratory sample*

CEN/TS 15359, *Solid recovered fuels — Specifications and classes*

CEN/TS 15414-1, *Solid recovered fuels — Determination of moisture content using the oven dry method — Part 1: Determination of total moisture by a reference method*

CEN/TS 15414-2, *Solid recovered fuels — Determination of moisture content using the oven dry method — Part 2: Determination of total moisture by a simplified procedure*

3 Terms and definitions

For the purposes of this document, the terms and definitions given in prEN 15357:2008 apply.

4 Principle

Both mass and volume of an individual particle or a group of particles are determined. The volume is measured by determining the buoyancy in a liquid. This procedure follows the physical principle that the buoyancy of a body is equal to the mass of the displaced volume of a liquid. The apparent loss in mass between a measurement in air and a subsequent measurement in liquid marks its buoyancy. The volume of the sample body is calculated via the density of the applied liquid.

CEN/TS 15405:2010 (E)

5 Apparatus

5.1 General apparatus requirements

5.1.1 **Thermometer** for liquids, with an accuracy of 1 °C.

5.1.2 **Facilities** for the determination of moisture content in accordance with CEN/TS 15414-2.

5.2 Apparatus for pellet testing

5.2.1 **Balance**, readable to 0,001 g. Due to the high sensitivity of the balance, the test rig shall be placed into a wind protection cabinet to allow undisturbed and immediate reading of the displayed values.

5.2.2 **Beaker glass**, transparent, with a filling volume of about 200 ml.

5.2.3 **Thermometer** for liquids, with an accuracy of 1 °C.

5.2.4 **Rig** for the determination of density, capable of being placed on the balance.

The rig shall be consisted of a bridge which overstretches the weighing plate of the balance in order to prevent the balance from being loaded. The bridge shall be capable of carrying the beaker glass (5.2.2). Through a supporting frame with suspension rods, a weighing dish („submergence dish“) shall be hung into the beaker glass (see Figure 1) which is filled with liquid. The dish shall be able to accommodate four pellets at once. Both the supporting frame and the submergence dish shall be directly loaded on the balance plate. The submergence apparatus (the dish and the suspension) shall be able to be removed for being loaded with pellets. The submergence depth shall always be kept constant through the dish suspension. The bottom of the submergence dish shall be perforated by openings which are smaller in diameter than the diameter of the pellets. This perforation allows the liquid to fill the dish from underneath if it is submerged. If sample material of low density shall be applied ($< 1,0 \text{ g/cm}^3$), a modified suspension with an inverted submergence dish is required; this is to prevent pellets from floating atop of the liquid. For the determination of the mass in air, it is advantageous to use a combined test rig where an additional upper weighing dish is fixed (see Figure 1).

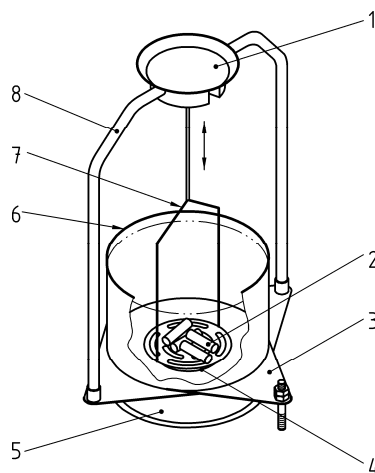

Key

1	weighing dish, for weighing in air	5	weighing plate
2	pellets	6	beaker glass
3	bridge	7	dish suspension
4	perforated submergence dish, for weighing in water	8	supporting frame

Figure 1 — Buoyancy determination rig on a balance (method for pellets)

5.3 Apparatus for briquette testing

5.3.1 Balance, readable to 0,01 g. If briquettes of more than 500 g each shall be tested, the readability of the balance may be reduced to 0,1 g. The balance shall have a connecting point for hanging a weight to its load cell.

5.3.2 Container, transparent, for liquids, with a sufficient filling volume to accommodate the liquid and the submerged briquette.

NOTE A sufficient filling volume is usually achieved when the cross section of the container is about eight times larger than the cross section of the briquette. In this case, any effects by level changes of the liquid caused by submersion of the briquette are negligible. Such deviation would arise due to a larger part of the holding steel string being submerged.

5.3.3 Thin steel string, non absorbent, able to be hung to the connecting point of the balance; the end of the string is equipped with a hook or a ring allowing an easy appending of the sample.

5.3.4 Tripod, for placing the balance on, having a plate with an opening allowing the string to pass through unhindered while hanging to the balance (see Figure 2).

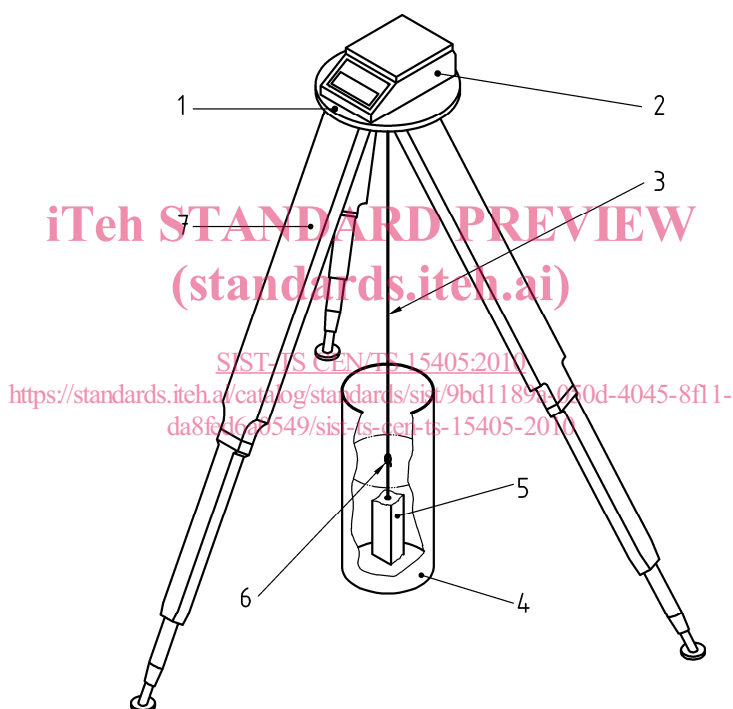

Key

- | | | | |
|---|-----------------------------|---|-------------------------|
| 1 | carrying plate with opening | 5 | test sample (briquette) |
| 2 | balance | 6 | connecting ring or hook |
| 3 | steel string | 7 | tripod |
| 4 | liquid container | | |

Figure 2 — Buoyancy determination rig using a hanging load to a balance (method for briquettes)

5.3.5 Steel support device, e.g. a steel loop, allowing to fix the briquette to the lower connecting point of the string.

5.3.6 Removable weight, in the case of testing a sample material of low density ($< 1,0 \text{ g/cm}^3$), placed onto the sample in a way which prevents the briquette from floating atop of the liquid.