**Wrought aluminium and aluminium alloy
extruded rods/bars, tubes and profiles —**

Part 3:

**Extruded rectangular bars — Tolerances on
shape and dimensions**

iTeh STANDARD PREVIEW

*Barres, tubes et profilés filés en aluminium et alliages d'aluminium
corroyés*

*Partie 3: Barres rectangulaires filées — Tolérances sur dimensions et
forme* [ISO 6362-3:2001](https://standards.iteh.ai/catalog/standards/sist/e314c371-cb07-4c98-a83a-6ef133879e8f/iso-6362-3-2001)

<https://standards.iteh.ai/catalog/standards/sist/e314c371-cb07-4c98-a83a-6ef133879e8f/iso-6362-3-2001>



PDF disclaimer

This PDF file may contain embedded typefaces. In accordance with Adobe's licensing policy, this file may be printed or viewed but shall not be edited unless the typefaces which are embedded are licensed to and installed on the computer performing the editing. In downloading this file, parties accept therein the responsibility of not infringing Adobe's licensing policy. The ISO Central Secretariat accepts no liability in this area.

Adobe is a trademark of Adobe Systems Incorporated.

Details of the software products used to create this PDF file can be found in the General Info relative to the file; the PDF-creation parameters were optimized for printing. Every care has been taken to ensure that the file is suitable for use by ISO member bodies. In the unlikely event that a problem relating to it is found, please inform the Central Secretariat at the address given below.

iTeh STANDARD PREVIEW
(standards.iteh.ai)

ISO 6362-3:2001

<https://standards.iteh.ai/catalog/standards/sist/e314c371-cb07-4c98-a83a-6ef133879e8f/iso-6362-3-2001>

© ISO 2001

All rights reserved. Unless otherwise specified, no part of this publication may be reproduced or utilized in any form or by any means, electronic or mechanical, including photocopying and microfilm, without permission in writing from either ISO at the address below or ISO's member body in the country of the requester.

ISO copyright office
Case postale 56 • CH-1211 Geneva 20
Tel. + 41 22 749 01 11
Fax + 41 22 749 09 47
E-mail copyright@iso.ch
Web www.iso.ch

Printed in Switzerland

Foreword

ISO (the International Organization for Standardization) is a worldwide federation of national standards bodies (ISO member bodies). The work of preparing International Standards is normally carried out through ISO technical committees. Each member body interested in a subject for which a technical committee has been established has the right to be represented on that committee. International organizations, governmental and non-governmental, in liaison with ISO, also take part in the work. ISO collaborates closely with the International Electrotechnical Commission (IEC) on all matters of electrotechnical standardization.

International Standards are drafted in accordance with the rules given in the ISO/IEC Directives, Part 3.

Draft International Standards adopted by the technical committees are circulated to the member bodies for voting. Publication as an International Standard requires approval by at least 75 % of the member bodies casting a vote.

Attention is drawn to the possibility that some of the elements of this part of ISO 6362 may be the subject of patent rights. ISO shall not be held responsible for identifying any or all such patent rights.

International Standard ISO 6362-3 was prepared by Technical Committee ISO/TC 79, *Light metals and their alloys*, Subcommittee SC 6, *Wrought aluminium and aluminium alloys*.

This second edition cancels and replaces the first edition (ISO 6362-3:1990), which has been technically revised.

ISO 6362 consists of the following parts, under the general title *Wrought aluminium and aluminium alloy extruded rods/bars, tubes and profiles*:

- *Part 1: Technical conditions for inspection and delivery*
- *Part 2: Mechanical properties*
- *Part 3: Extruded rectangular bars — Tolerances on shape and dimensions*
- *Part 4: Extruded profiles — Tolerances on shape and dimensions*
- *Part 5: Extruded round, square and hexagonal bars — Tolerances on shape and dimensions*

Annex A of this part of ISO 6362 is for information only.

iTeh STANDARD PREVIEW
(standards.iteh.ai)

ISO 6362-3:2001

<https://standards.iteh.ai/catalog/standards/sist/e314c371-cb07-4c98-a83a-6ef133879e8f/iso-6362-3-2001>

Wrought aluminium and aluminium alloy extruded rods/bars, tubes and profiles —

Part 3: Extruded rectangular bars — Tolerances on shape and dimensions

1 Scope

This part of ISO 6362 specifies the tolerances on dimensions and shape of wrought aluminium and aluminium alloy extruded rectangular bars, having thicknesses in the range from 2 mm up to and including 240 mm and widths in the range from 10 mm up to and including 600 mm.

For rectangular bars, the technical conditions for inspection and delivery and the mechanical properties are as specified in ISO 6362-1 and ISO 6362-2.

iTeh STANDARD PREVIEW
(standards.iteh.ai)

2 Normative references

The following normative documents contain provisions which, through reference in this text, constitute provisions of this part of ISO 6362. For dated references, subsequent amendments to, or revisions of, any of these publications do not apply. However, parties to agreements based on this part of ISO 6362 are encouraged to investigate the possibility of applying the most recent editions of the normative documents indicated below. For undated references, the latest edition of the normative document referred to applies. Members of ISO and IEC maintain registers of currently valid International Standards.

ISO 6362-1:1986, *Wrought aluminium and aluminium alloy extruded rods/bars, tubes and profiles — Part 1: Technical conditions for inspection and delivery.*

ISO 6362-2:1990, *Wrought aluminium and aluminium alloy extruded rods/bars, tubes and profiles — Part 2: Mechanical properties.*

3 Materials

For the purposes of this part of ISO 6362, wrought aluminium and aluminium alloys are divided into two groups which correspond to varying difficulty when manufacturing the products.

The division into Group I and Group II of the most commonly used general engineering alloys is specified in annex A.

4 Tolerances on shape and dimensions

4.1 Dimensional tolerances

4.1.1 Tolerances on width and thickness

Tolerances on width and thickness shall be in accordance with Tables 1 and 2.

Table 1 — Tolerances on width and thickness for alloy group I

Dimensions in millimetres

Width <i>b</i>		Thickness <i>t</i> tolerances for thickness ranges								
Range	Tolerance	$2 \leq t \leq 6$	$6 < t \leq 10$	$10 < t \leq 18$	$18 < t \leq 30$	$30 < t \leq 50$	$50 < t \leq 80$	$80 < t \leq 120$	$120 < t \leq 180$	$180 < t \leq 240$
$10 < b \leq 18$	$\pm 0,25$	$\pm 0,20$	$\pm 0,25$	$\pm 0,25$	—	—	—	—	—	—
$18 < b \leq 30$	$\pm 0,30$	$\pm 0,20$	$\pm 0,25$	$\pm 0,30$	$\pm 0,30$	—	—	—	—	—
$30 < b \leq 50$	$\pm 0,40$	$\pm 0,25$	$\pm 0,25$	$\pm 0,30$	$\pm 0,35$	$\pm 0,40$	—	—	—	—
$50 < b \leq 80$	$\pm 0,60$	$\pm 0,25$	$\pm 0,30$	$\pm 0,35$	$\pm 0,40$	$\pm 0,50$	$\pm 0,60$	—	—	—
$80 < b \leq 120$	$\pm 0,80$	$\pm 0,30$	$\pm 0,35$	$\pm 0,40$	$\pm 0,45$	$\pm 0,60$	$\pm 0,70$	$\pm 0,80$	—	—
$120 < b \leq 180$	$\pm 1,0$	$\pm 0,40$	$\pm 0,45$	$\pm 0,50$	$\pm 0,55$	$\pm 0,60$	$\pm 0,70$	$\pm 0,90$	$\pm 1,0$	—
$180 < b \leq 240$	$\pm 1,4$	—	$\pm 0,55$	$\pm 0,60$	$\pm 0,65$	$\pm 0,70$	$\pm 0,80$	$\pm 1,0$	$\pm 1,2$	$\pm 1,4$
$240 < b \leq 350$	$\pm 1,8$	—	$\pm 0,65$	$\pm 0,70$	$\pm 0,75$	$\pm 0,80$	$\pm 0,90$	$\pm 1,1$	$\pm 1,3$	$\pm 1,5$
$350 < b \leq 450$	$\pm 2,2$	—	—	$\pm 0,80$	$\pm 0,85$	$\pm 0,90$	$\pm 1,0$	$\pm 1,2$	$\pm 1,4$	$\pm 1,6$
$450 < b \leq 600$	$\pm 3,0$	—	—	—	$\pm 0,90$	$\pm 1,0$	$\pm 1,4$	—	—	—

<https://standards.iteh.ai/catalog/standards/sist/e314c371-cb07-4c98-a83a-6ef133879e8f/iso-6362-3-2001>

Table 2 — Tolerances on width and thickness for alloy group II

Dimensions in millimetres

Width <i>b</i>		Thickness <i>t</i> tolerances for thickness ranges								
Range	Tolerance	$2 \leq t \leq 6$	$6 < t \leq 10$	$10 < t \leq 18$	$18 < t \leq 30$	$30 < t \leq 50$	$50 < t \leq 80$	$80 < t \leq 120$	$120 < t \leq 180$	$180 < t \leq 240$
$10 < b \leq 18$	$\pm 0,35$	$\pm 0,25$	$\pm 0,30$	$\pm 0,35$	—	—	—	—	—	—
$18 < b \leq 30$	$\pm 0,40$	$\pm 0,25$	$\pm 0,30$	$\pm 0,40$	$\pm 0,40$	—	—	—	—	—
$30 < b \leq 50$	$\pm 0,50$	$\pm 0,30$	$\pm 0,30$	$\pm 0,40$	$\pm 0,50$	$\pm 0,50$	—	—	—	—
$50 < b \leq 80$	$\pm 0,60$	$\pm 0,30$	$\pm 0,35$	$\pm 0,45$	$\pm 0,60$	$\pm 0,70$	$\pm 0,70$	—	—	—
$80 < b \leq 120$	$\pm 1,0$	$\pm 0,35$	$\pm 0,40$	$\pm 0,50$	$\pm 0,60$	$\pm 0,70$	$\pm 0,80$	$\pm 1,0$	—	—
$120 < b \leq 180$	$\pm 1,4$	$\pm 0,45$	$\pm 0,50$	$\pm 0,55$	$\pm 0,70$	$\pm 0,80$	$\pm 1,0$	$\pm 1,1$	$\pm 1,4$	—
$180 < b \leq 240$	$\pm 1,8$	—	$\pm 0,60$	$\pm 0,65$	$\pm 0,70$	$\pm 0,90$	$\pm 1,1$	$\pm 1,3$	$\pm 1,6$	$\pm 1,8$
$240 < b \leq 350$	$\pm 2,2$	—	$\pm 0,70$	$\pm 0,75$	$\pm 0,80$	$\pm 0,90$	$\pm 1,2$	$\pm 1,4$	$\pm 1,7$	$\pm 1,9$
$350 < b \leq 450$	$\pm 2,8$	—	—	$\pm 0,90$	$\pm 1,0$	$\pm 1,1$	$\pm 1,4$	$\pm 1,8$	$\pm 2,1$	$\pm 2,3$
$450 < b \leq 600$	$\pm 3,5$	—	—	—	—	$\pm 1,2$	$\pm 1,4$	$\pm 1,8$	—	—

4.1.2 Corner radii

Maximum corner radii shall be in accordance with Table 3.

Table 3 — Maximum corner radii

Dimensions in millimetres

Thickness <i>t</i>	Maximum corner radii	
	Alloy Group I	Alloy Group II
$2 < t \leq 10$	0,6	1,0
$10 < t \leq 30$	1,0	1,5
$30 < t \leq 80$	1,8	2,5
$80 < t \leq 120$	2,0	3,0
$120 < t \leq 180$	2,5	4,0
$180 < t \leq 240$	3,5	5,0

4.1.3 Fixed-length tolerances

If fixed lengths are to be supplied, this shall be stated on the order. The permissible tolerances on fixed lengths are given in Table 4.

If no fixed or minimum length is specified in the order, rectangular bars may be delivered in random length. The actual lengths and tolerances on random lengths shall be agreed between purchaser and supplier.

Table 4 — Fixed-length tolerances

Dimensions in millimetres

Width <i>b</i>	Tolerances on fixed length		
	$L \leq 2\,000$	$2\,000 < L \leq 5\,000$	$L > 5\,000$
$b \leq 100$	$\begin{matrix} +5 \\ 0 \end{matrix}$	$\begin{matrix} +7 \\ 0 \end{matrix}$	$\begin{matrix} +10 \\ 0 \end{matrix}$
$100 < b \leq 200$	$\begin{matrix} +7 \\ 0 \end{matrix}$	$\begin{matrix} +9 \\ 0 \end{matrix}$	$\begin{matrix} +12 \\ 0 \end{matrix}$
$200 < b \leq 450$	$\begin{matrix} +8 \\ 0 \end{matrix}$	$\begin{matrix} +11 \\ 0 \end{matrix}$	$\begin{matrix} +14 \\ 0 \end{matrix}$
$450 < b \leq 600$	$\begin{matrix} +9 \\ 0 \end{matrix}$	$\begin{matrix} +12 \\ 0 \end{matrix}$	$\begin{matrix} +16 \\ 0 \end{matrix}$

4.2 Shape tolerances

The shape tolerances specified in 4.2.1 to 4.2.3 apply to all tempers, except tempers O and T×510.

The deviation shall be measured with the bar supported on a horizontal base plate, such that the deviation is minimized by the weight of the bar.

4.2.1 Flatness tolerances

Flatness tolerances shall be in accordance with Table 5.

Table 5 — Flatness tolerances

Dimensions in millimetres

Width <i>b</i>	Tolerance for convexity or concavity <i>e</i>
$10 < b \leq 30$	0,2
$30 < b \leq 50$	0,3
$50 < b \leq 80$	0,4
$80 < b \leq 120$	0,6
$120 < b \leq 180$	0,9
$180 < b \leq 240$	1,2
$240 < b \leq 350$	1,5
$350 < b \leq 450$	2,0
$450 < b \leq 600$	2,5

The deviation from flatness e_f shall be measured in accordance with Figure 1.

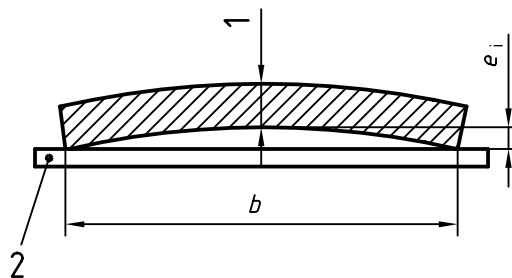

Key

- 1 Thickness
- 2 Base plate

Figure 1 — Measurement of deviation from flatness

4.2.2 Straightness tolerances

For rectangular bars of thickness equal to or greater than 10 mm, the straightness tolerances shall be in accordance with Table 6.

Table 6 — Straightness tolerances

Dimensions in millimetres

Width b	Thickness t		Straightness tolerances	
			per 1 000 mm of length $(l_1) h_1$	in any 300 mm $(l_2) h_2$
$10 < b \leq 80$	≥ 10	≤ 80	2	1
$80 < b \leq 120$	≥ 10	≤ 50	2	1
	> 50	≤ 120	3	1,5
$120 < b \leq 180$	≥ 10	≤ 50	3	1,5
	> 50	≤ 180	4	2
$180 < b \leq 350$	≥ 10	≤ 50	4	2
	> 50	≤ 240	6	4
$350 < b \leq 450$	≥ 10	≤ 240	6	4
$450 < b \leq 600$	30	≤ 120	6	4

<https://standards.iteh.ai/catalog/standards/sist/e314c371-cb07-4c98-a83a-118118118118>

For rectangular bars of thickness less than 10 mm, the straightness tolerances shall be agreed upon between supplier and purchaser.

The deviations from straightness h_{1i} and h_{2i} shall be measured as shown in Figure 2, with the bar placed on a horizontal base plate so that its mass decreases the deviation.

Dimensions in millimetres

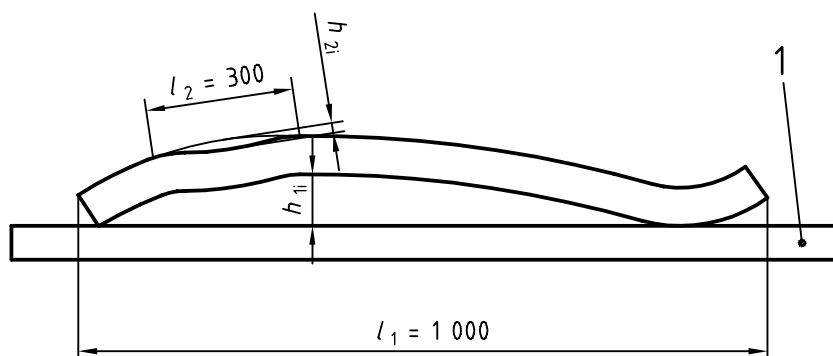

Key

- 1 Base plate

Figure 2 — Measurement of deviation from straightness