



# SLOVENSKI STANDARD

## SIST EN 13301:2010

01-junij-2010

Nadomešča:  
SIST EN 13301:2003

---

### Bitumen in bitumenska veziva - Ugotavljanje izločanja oljne komponente

Bitumen and bituminous binders - Determination of staining tendency of bitumen

Bitumen und bitumenhaltige Bindemittel - Bestimmung der Ausölneigung von Bitumen

Bitumes et liants bitumineux - Determination de la tendance à l'exsudation des bitumes  
**iTeh STANDARD PREVIEW**  
**(standards.iteh.ai)**

**Ta slovenski standard je istoveten z: ~~SIST EN 13301~~ EN 13301:2010**

<https://standards.iteh.ai/catalog/standards/sist/88e72745-d0c9-4760-8468-0962ed8e6e9f/sist-en-13301-2010>

---

#### **ICS:**

75.140	Voski, bitumni in drugi naftni proizvodi	Waxes, bituminous materials and other petroleum products
91.100.50	Veziva. Tesnilni materiali	Binders. Sealing materials

**SIST EN 13301:2010**

**en,fr,de**

**iTeh STANDARD PREVIEW**  
**(standards.iteh.ai)**

SIST EN 13301:2010

<https://standards.iteh.ai/catalog/standards/sist/88e72745-d0c9-4760-8468-0962ed8e6c9f/sist-en-13301-2010>

EUROPEAN STANDARD

**EN 13301**

NORME EUROPÉENNE

EUROPÄISCHE NORM

March 2010

ICS 75.140; 91.100.50

Supersedes EN 13301:2003

English Version

## Bitumen and bituminous binders - Determination of staining tendency of bitumen

Bitumes et liants bitumineux - Détermination de la tendance à l'exsudation des bitumes

Bitumen und bitumenhaltige Bindemittel - Bestimmung der Ausölneigung von Bitumen

This European Standard was approved by CEN on 23 January 2010.

CEN members are bound to comply with the CEN/CENELEC Internal Regulations which stipulate the conditions for giving this European Standard the status of a national standard without any alteration. Up-to-date lists and bibliographical references concerning such national standards may be obtained on application to the CEN Management Centre or to any CEN member.

This European Standard exists in three official versions (English, French, German). A version in any other language made by translation under the responsibility of a CEN member into its own language and notified to the CEN Management Centre has the same status as the official versions.

CEN members are the national standards bodies of Austria, Belgium, Bulgaria, Croatia, Cyprus, Czech Republic, Denmark, Estonia, Finland, France, Germany, Greece, Hungary, Iceland, Ireland, Italy, Latvia, Lithuania, Luxembourg, Malta, Netherlands, Norway, Poland, Portugal, Romania, Slovakia, Slovenia, Spain, Sweden, Switzerland and United Kingdom.

[SIST EN 13301:2010](https://standards.iteh.ai/catalog/standards/sist/88e72745-d0c9-4760-8468-0962ed8e6c9f/sist-en-13301-2010)

<https://standards.iteh.ai/catalog/standards/sist/88e72745-d0c9-4760-8468-0962ed8e6c9f/sist-en-13301-2010>



EUROPEAN COMMITTEE FOR STANDARDIZATION  
COMITÉ EUROPÉEN DE NORMALISATION  
EUROPÄISCHES KOMITEE FÜR NORMUNG

Management Centre: Avenue Marnix 17, B-1000 Brussels

## Contents

Page

Foreword.....	3
1 Scope .....	4
2 Normative references .....	4
3 Terms and definitions .....	4
4 Principle.....	4
5 Apparatus .....	4
6 Sampling.....	6
7 Procedure .....	6
7.1 Sample preparation .....	6
7.2 Filling of the rings.....	6
7.3 Filling of the rings (alternative procedure to 7.2) .....	6
7.4 Oven conditioning and measurement .....	6
8 Calculation.....	7
9 Expression of results.....	7
10 Precision.....	7
10.1 Repeatability.....	7
10.2 Reproducibility.....	7
11 Test report .....	7

iTeh STANDARD PREVIEW  
 (standards.iteh.ai)  
 SIST EN 13301:2010  
<https://standards.iteh.ai/catalog/standards/sist/88e72745-d0c9-4760-8468-0962ed8e6c9f/sist-en-13301-2010>

## Foreword

This document (EN 13301:2010) has been prepared by Technical Committee CEN/TC 336 "Bituminous binders", the secretariat of which is held by AFNOR.

This European Standard shall be given the status of a national standard, either by publication of an identical text or by endorsement, at the latest by September 2010, and conflicting national standards shall be withdrawn at the latest by September 2010.

Attention is drawn to the possibility that some of the elements of this document may be the subject of patent rights. CEN [and/or CENELEC] shall not be held responsible for identifying any or all such patent rights.

This document supersedes EN 13301:2003.

This document contains three significant changes compared to EN 13301:2003:

- 1) The filter paper specified in Clause 5.4 is now described in technical terms, and not by reference to commercial grades of filter paper (like Whatman No. 40).
- 2) Now there exist two procedures of equal standing for filling the rings (Clause 7.2 and Clause 7.3) to be chosen by the individual laboratory.
- 3) Results are rounded to nearest 0,5 mm.

According to the CEN/CENELEC Internal Regulations, the national standards organizations of the following countries are bound to implement this European Standard: Austria, Belgium, Bulgaria, Croatia, Cyprus, Czech Republic, Denmark, Estonia, Finland, France, Germany, Greece, Hungary, Iceland, Ireland, Italy, Latvia, Lithuania, Luxembourg, Malta, Netherlands, Norway, Poland, Portugal, Romania, Slovakia, Slovenia, Spain, Sweden, Switzerland and the United Kingdom.

## EN 13301:2010 (E)

### 1 Scope

This European Standard specifies a method for the determination of the staining tendency of bitumen.

This method is applicable to bitumen having a Ring-and-Ball softening point greater than or equal to 80 °C. For softer bitumen, the test conditions may be modified by agreement between the involved parties.

The procedure described in this document may be used to compare results against a material for which the staining tendency is known.

**NOTE** Staining properties are related to the colloidal stability of the bitumen with higher values indicating lower stability.

**WARNING — The use of this standard can involve hazardous materials, operations and equipment. This standard does not purport to address all of the safety problems associated with its use. It is the responsibility of the user of this standard to establish appropriate safety and health practices and to determine the applicability of regulatory limitations prior to use.**

### 2 Normative references

The following referenced documents are indispensable for the application of this document. For dated references, only the edition cited applies. For undated references, the latest edition of the referenced document (including any amendments) applies.

EN 58, *Bitumen and bituminous binders — Sampling bituminous binders*

EN 1427, *Bitumen and bituminous binders — Determination of softening point — Ring and Ball method*

EN 12594, *Bitumen and bituminous binders — Preparation of test samples*

<https://standards.iteh.ai/catalog/standards/sist/88e72745-d0c9-4760-8468-0962ed8e6c9f/sist-en-13301-2010>

### 3 Terms and definitions

For the purposes of this document, the following terms and definitions apply.

#### 3.1

##### **staining tendency**

tendency of oil components to separate spontaneously from bitumen

**NOTE** The separation of oil components can cause staining in bitumen roofing products and others bituminous products with eventual damage of adjacent materials in storage and use.

### 4 Principle

A retaining ring, filled with molten bitumen on a sheet of filter paper and supported on a flat horizontal plate is heated in an oven at a specified temperature for a specified time. The width of the resulting stained circle around the bitumen is calculated to determine the staining tendency of the bitumen. The staining tendency has the dimension of length and results are rounded to nearest 0,5 mm.

### 5 Apparatus

**5.1 Rings**, square-shouldered as specified in EN 1427 (see Figure 1).

The precision of the method depends upon accurate measurement of the diameter and precise alignment of the face and rim of the ring on a flat surface and it is essential that deformed rings shall not be used.

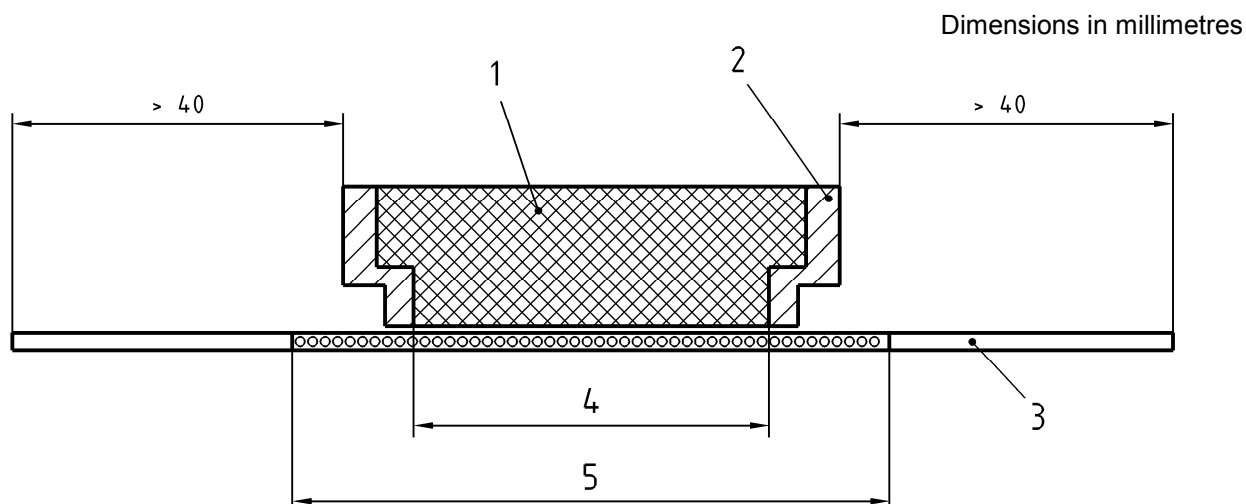
**Key**

- 1 Bitumen
- 2 Ring according to EN 1427
- 3 Filter paper
- 4 Inner diameter of ring
- 5 Diameter of stained circle

STANDARD PREVIEW  
(standards.iteh.ai)

**Figure 1 — Ring**

SIST EN 13301:2010

<https://standards.iteh.ai/catalog/standards/sist/88e72745-d0c9-4760-8468-0962ed8e6c9f/sist-en-13301-2010>

**5.2 Baking paper**, silicone treated paper to be used when casting discs of bitumen in the rings.

**5.3 Release agent**, mixture of glycerol and dextrin or mineral talc, or other commercially available release agent. To prevent adhesion of bituminous binder to the pouring plate when casting discs, the surface of the metal pouring plate shall be thinly coated just before use with the release agent.

NOTE Applying the release agent coating is easier when the plate is warmed to approximately 40 °C.

**5.4 Filter paper**, standard cellulose fibre ashless analytical grade. The filter paper shall be of sufficient area to accommodate the number of samples under test.

A filter paper having a porosity of approximately 8 µm with a thickness of approximately 210 µm or a basis mass of approximately 92 g/m<sup>2</sup> has been found to be suitable.

**5.5 Support plate**, a flat, clean, smooth metal plate approximately 1,5 mm thick and with an area at least sufficient to support the size of filter paper used.

**5.6 Oven**, constant temperature, capable of maintaining a sample temperature of (80 ± 1) °C.

**5.7 Thermometer**, with a reading accuracy of ± 0,1 °C in the required temperature range.

**5.8 Measuring rule or device**, with a reading accuracy of 0,5 mm or better.

**EN 13301:2010 (E)****6 Sampling**

The material under test shall be sampled in accordance with EN 58 and prepared in accordance with EN 12594.

**7 Procedure****7.1 Sample preparation**

The bulk binder sample shall be placed in an oven maintained at a temperature of about 80 °C above the expected ring and ball softening point temperature or at a maximum of 200 °C whichever is the lower.

The container shall be filled to at least 50 % of its volume and shall be covered with a loose lid to protect it against oxidation.

The total heating time shall be within 1 h 15 min to 1 h 45 min for samples of 100 ml to < 500 ml and 1 h 45 min to 2 h 15 min for samples of ≥ 500 ml to < 1 000 ml.

**7.2 Filling of the rings**

Place preheated rings on the baking paper no closer than 40 mm from each other (preheated to a maximum of 90 °C above the softening point). Ensure that the lower face and rim of the ring diameter is clean and that the bitumen disc will completely fill the ring and is flush with the lower face. Ensure that there are no traces of any release agent on the support plate or the ring.

Pour the bitumen sample into a preheated ring, using 2 rings per sample, placed on the baking paper on the support plate.

Allow to cool to ambient temperature and trim off the excess bitumen from the top of the ring as described in EN 1427.

Place the filled rings on the filter paper, placed on the support plate, no closer than 40 mm from the edge of the paper or from another ring.

**NOTE** When the sample is highly viscous, it may be difficult to pour into the rings. If excess bitumen has flown over the ring edge to the filter paper, it may stain the paper before the actual test.

Continue to 7.4.

**7.3 Filling of the rings (alternative procedure to 7.2)**

Place rings no closer than 40 mm from the edge of the filter paper or from another ring, ensuring that the lower face and rim of the ring diameter is clean and that the bitumen disc will completely fill the ring and is flush with the lower face. Ensure that there are no traces of any release agent on the support plate or the ring.

Pour the bitumen sample into a preheated ring (preheated to a maximum of 90 °C above softening point) using 2 rings per sample, placed on the filter paper on the support plate.

Allow to cool to ambient temperature, and trim off the excess bitumen from the top of the ring as described in EN 1427.

**7.4 Oven conditioning and measurement**

Identify each bitumen sample by appropriately marking the filter paper in pencil near its ring.