



Designation: D 5640 – 95 (Reapproved 2003)

Standard Guide for Selection of Weirs and Flumes for Open-Channel Flow Measurement of Water¹

This standard is issued under the fixed designation D 5640; the number immediately following the designation indicates the year of original adoption or, in the case of revision, the year of last revision. A number in parentheses indicates the year of last reapproval. A superscript epsilon (ϵ) indicates an editorial change since the last revision or reapproval.

1. Scope

1.1 This guide covers recommendations for the selection of weirs and flumes for the measurement of the volumetric flow rate of water and wastewater in open channels under a variety of field conditions.

1.2 This guide emphasizes the weirs and flumes for which ASTM standards are available, namely, thin-plate weirs, broad-crested weirs, Parshall flumes, and Palmer-Bowlus (and other long-throated) flumes. However, reference is also made to other measurement devices and methods that may be useful in specific situations.

1.3 *This standard does not purport to address all of the safety concerns, if any, associated with its use. It is the responsibility of the user of this standard to establish appropriate safety and health practices and determine the applicability of regulatory limitations prior to use.*

2. Referenced Documents

2.1 ASTM Standards:

D 1129 Terminology Relating to Water²

D 1941 Test Method for Open Channel Flow Measurement of Water with the Parshall Flume²

D 3858 Test Method for Open-Channel Flow Measurement of Water by Velocity-Area Method²

D 5242 Test Method for Open-Channel Flow Measurement of Water with Thin-Plate Weirs²

D 5389 Test Method for Open-Channel Flow Measurement of Water by Acoustic Velocity Meter Systems²

D 5390 Test Method for Open-Channel Flow Measurement of Water with Palmer-Bowlus Flume²

D 5614 Test Method for Open-Channel Flow Measurement of Water with Broad-Crested Weirs²

2.2 ISO Standard:

ISO 555-1973: Liquid Flow Measurement in Open Channels—Dilution Methods for Measurement of Steady

Flow—Constant-Rate Injection Method³

3. Terminology

3.1 *Definitions*—For definitions of terms used in this guide, refer to Terminology D 1129.

3.2 *Definitions of Terms Specific to This Standard:*

3.2.1 *blackwater*—an increase in the depth of flow upstream of a channel obstruction, in this case a weir or flume.

3.2.2 *contracted weirs*—contractions of thin-plate weirs refer to the widths of weir plate between the notch and the sidewalls of the approach channel. In fully contracted weirs, the ratio of the notch area to the cross-sectional area of the approach channel is small enough for the shape of the channel to have little effect. In suppressed (full-width) rectangular weirs, the contractions are suppressed, and the weir crest extends the full width of the channel.

3.2.3 *crest*—in rectangular thin-plate weirs, the horizontal bottom of the overflow section; in broad-crested weirs and flumes, the plane, level floor of the flow section.

3.2.4 *critical flow*—open-channel flow in which the energy, expressed in terms of depth plus velocity head, is a minimum for a given flow rate and channel.

3.2.4.1 *Discussion*—The Froude number is unity at critical flow.

3.2.5 *Froude number*—a dimensionless number expressing the ratio of inertial to gravity forces in free-surface flow. It is equal to the average velocity divided by the square root of the product of the average depth and the acceleration due to gravity.

3.2.6 *head*—in this context, the depth of flow referenced to the crest of the weir or flume and measured at a specified location; this depth plus the velocity head are often termed the total head or total energy head.

3.2.7 *hydraulic jump*—an abrupt transition from supercritical to subcritical or tranquil flow, accompanied by considerable turbulence or gravity waves, or both.

3.2.8 *long-throated flume*—a flume in which the prismatic throat is long enough, relative to the head, for a region of essentially critical flow to develop on the crest.

¹ This guide is under the jurisdiction of ASTM Committee D19 on Water and is the direct responsibility of Subcommittee D19.07 on Sediments, Geomorphology, and Open-Channel Flow.

Current edition approved June 10, 2003. Published August 2003. Originally approved in 1995. Last previous edition approved in 1999 as D 5640 – 95 (1999).

² *Annual Book of ASTM Standards*, Vol 11.01.

³ Available from American National Standards Institute (ANSI), 25 W. 43rd St., 4th Floor, New York, NY 10036.

3.2.9 *nappe*—the curved sheet or jet of water overfalling a weir.

3.2.10 *notch*—the overflow section of a triangular weir or of a rectangular weir with side contractions.

3.2.11 *primary instrument*—the device (in this case, a weir or flume) that creates a hydrodynamic condition that can be sensed by the secondary instrument.

3.2.12 *rangeability*—the spread between the maximum, Q_{max} , and minimum, Q_{min} , flow rates that a measuring instrument can usefully and reliably accommodate; this may be described as the ratio Q_{max}/Q_{min} .

3.2.13 *secondary instrument*—in this case, a device that measures the head on the weir or flume; it may also convert this measured head to an indicated flowrate or could totalize the flow.

3.2.14 *subcritical flow*—open-channel flow that is deeper and at a lower velocity than critical flow for the same flow rate; sometimes called tranquil flow.

3.2.14.1 *Discussion*—The Froude number is less than unity for this flow.

3.2.15 *submergence*—the ratio of downstream head to upstream head on a weir or flume. Submergence greater than a critical value affects the discharge for a given upstream head.

3.2.16 *supercritical flow*—open-channel flow that is shallower and at higher velocity than critical flow for the same flow rate.

3.2.16.1 *Discussion*—The Froude number is greater than unity for this flow.

3.2.17 *throat*—the constricted portion of a flume.

3.2.18 *velocity head*—the square of the average velocity divided by twice the acceleration due to gravity.

4. Significance and Use

4.1 Each type of weir and flume possesses advantages and disadvantages relative to the other types when it is considered for a specific application; consequently, the selection process often involves reaching a compromise among several features. This guide is intended to assist the user in making a selection that is hydraulically, structurally, and economically appropriate for the purpose.

4.2 It is recognized that not all open-channel situations are amenable to flow measurement by weirs and flumes and that in some cases, particularly in large streams, discharges may best be determined by other means. (See 6.2.2.)

5. Weirs and Flumes

5.1 Weirs:

5.1.1 Weirs are overflow structures of specified geometries for which the volumetric flow rate is a unique function of a single measured upstream head, the other elements in the head-discharge relation having been experimentally or analytically determined. Details of the individual weirs may be found in the ASTM standards cited as follows:

5.1.2 *Standard Weirs*—The following weirs, for which ASTM standards are available, are considered in this guide:

5.1.2.1 Thin-plate weirs (see Test Method D 5242).

(1) Rectangular weirs (see Fig. 1).

(2) Triangular (V-notch) weirs (see Fig. 2).

5.1.2.2 Broad-crested weirs (see Test Method D 5614).

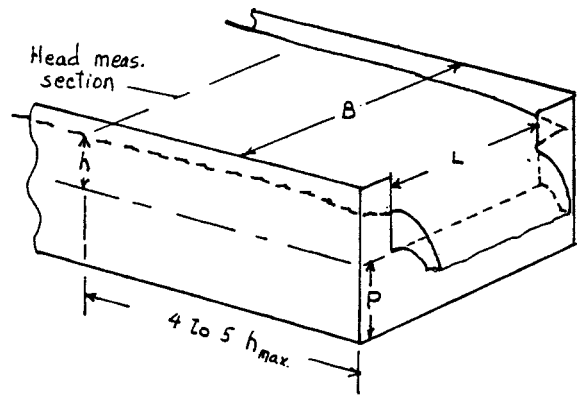

Limitations on geometry:^A $h/P \leq 2$
 $h \geq 0.1$ ft (0.03 m)
 $L \geq 0.5$ ft (0.15 m)
 $P \geq 0.3$ ft (0.1 m)

Approximate discharge equation, for selection purposes only:^B

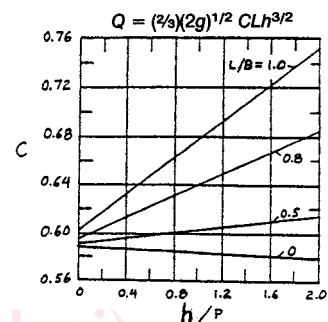

^A These limitations are for partially contracted weirs. See Test Method D 5242 for conditions on fully contracted weirs.

^B See Test Method D 5242 for more accurate standard equations. In compatible units, Q is flow rate, ft^3/s (m^3/s); g is acceleration due to gravity, ft/s^2 (m/s^2); h is head in ft. (m); C is coefficient shown in Fig. 1.

FIG. 1 Rectangular Thin-Plate Weirs

(1) Square-edge (rectangular) weirs (see Fig. 3).

(2) Rounded-edge weirs (see Fig. 4).

5.1.3 The quantitative information on weirs presented in Figs. 1-4 is intended to give the user only an overview and assist in the preliminary assessments for selection. To that end, some approximations and omissions were necessary for the sake of brevity and convenience, and the published standards must be consulted for exact and complete information on requirements, conditions, and equations.

5.2 Flumes:

5.2.1 Flumes use sidewall constrictions or bottom shapes or slopes of specified geometries, or both, to cause the flow to pass through the critical condition; this permits determination of the flow rate from a measured head and a head-discharge relation that has been experimentally or analytically obtained. Details of the individual flumes may be found in the ASTM standards cited as follows:

5.2.2 *Standard Flumes*—The following flumes, for which ASTM standards are available, are emphasized in this guide. Other flumes, which may be useful in specific situations, are cited in 5.2.4.

5.2.2.1 Parshall flumes (see Test Method D 1941, Fig. 5, and Table 1).

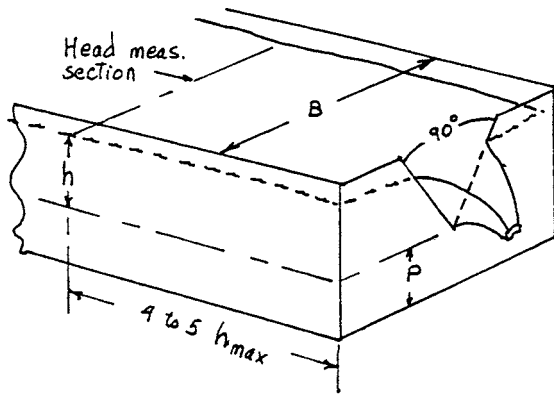

Limitations on geometry:^B $h/P \leq 1.2$
 $h/B \leq 0.4$
 $P \geq 0.3 \text{ ft (0.1 m)}$
 $B \geq 2 \text{ ft (0.6 m)}$
 $0.15 \text{ ft (0.05 m)} \leq h \leq 2 \text{ ft (0.6 m)}$

Approximate discharge equation, for selection purposes only:^C

$$C = (\theta/15)C(2g)^{1/2} (\tan \theta/2)h^{5/2}$$

^A A 90° notch is shown; information is also available on notch angles from 20 to 100; see Test Method D 5242.

^B These limits pertain to partially contracted 90° notches only. See Test Method D 5242 for other notch angles and full contractions.

^C C is approximately 0.58. See Test Method D 5242 for more accurate values of C and for the complete standard equation. Here θ is the notch angle, and the other terms are as described in footnote B of Fig. 1.

FIG. 2 Triangular Thin-Plate Weir^A

5.2.2.2 Palmer-Bowlus (and other long-throated) flumes (see Test Method D 5390 and Fig. 6).

5.2.3 The quantitative information on flumes presented in Fig. 5 and Fig. 6 is intended to give the user only an overview and assist in the preliminary assessments for selection. To that end, some approximations and omissions were necessary for the sake of brevity and convenience, and the published standards must be consulted for exact and complete information on requirements, conditions, and equations.

5.2.4 Other Flumes—The following flumes are not covered by ASTM standards but are listed here because they were developed for specific situations that may be of interest to users of this guide. Detailed information on them can be found in the reference section.

5.2.4.1 H-Series Flumes (1), (2)—This flume, which was developed for use on agricultural watersheds, is actually a combination of flume and triangular weir and consequently exhibits very high rangeability along with good sediment transport capability.

5.2.4.2 Portable Parshall Flume (1)—This 3-in. (7.6-cm) flume closely resembles the 3-in. standard Parshall flume with the downstream divergent section removed. Its small size makes it convenient to transport and install in some low-flow field applications.

5.2.4.3 Supercritical-Flow Flumes (1)—These flumes were developed for use in streams with heavy loads of coarse sediment. The depth measurement is made in the supercritical-flow portion of the flume rather than upstream.

6. Selection Criteria

6.1 Accuracy:

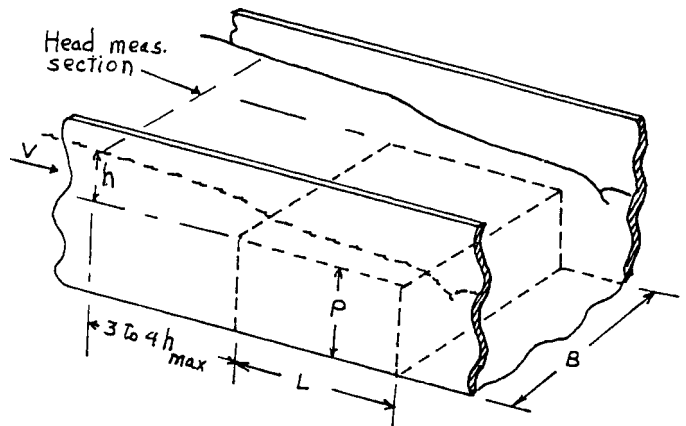

Limitations on geometry:^A $h \geq 0.2 \text{ ft (0.06 m)}$
 $b \geq 1.0 \text{ ft (0.3 m)}$
 $P \geq 0.5 \text{ ft (0.15 m)}$
 $0.1 < L/P < 4$
 $0.1 < h/L < 1.6$
 $h/P < 1.6$

Discharge equation:^B $Q = (2/3)^{3/2}(g)^{1/2} CBh^{3/2}$

Approximate C, for selection purposes only^C

h/P	h/L			
	0.2	0.6	1.0	1.6
0.1	0.85	0.88	0.97	(1.11)
0.5	0.88	0.91	1.01	1.15
1.0	(0.93)	0.96	1.06	1.19
1.5	(0.96)	1.02	1.11	1.24

^A See Test Method D 5390 for upstream transitions, allowable downstream-to-upstream head ratios, and other requirements.

^B Q, g, and h as described in Fig. 1, Footnote B.

^C See Test Method D 5390 for complete table; figures in parentheses are outside of the recommended geometric limits.

FIG. 3 Rectangular (Square-Edge) Broad-Crested Weirs

6.1.1 The error of a flow-rate measurement results from a combination of individual errors, including errors in the coefficients of the head-discharge relations; errors in the measurement of the head; and errors due to nonstandard shape or installation or other departures from the practices recommended in the various weir or flume standards, or both. This guide considers the accuracy of the primary devices only, based on their accuracy potential under optimum or standard conditions; from information included in the individual standards, users can estimate secondary-system errors and other errors to obtain an estimate of the total measurement error.

6.1.2 The errors inherent in the basic head-discharge relations of the primary devices are as follows:

6.1.2.1 Thin-Plate weirs:

- (1) Triangular, fully contracted, ± 1 to 2 %.
- (2) 90° notch, partially contracted, ± 2 to 3 %.
- (3) Rectangular, fully contracted, ± 1 to 2 %.
- (4) Rectangular, partially contracted, ± 2 to 3 %.

6.1.2.2 Broad-crested weirs:

- (1) Square-edge, ± 3 to 5 % (depending on head-to-weir height ratio).
- (2) Rounded, ± 3 % (in the optimum range of head-to-length ratio).

6.1.2.3 Flumes:

- (1) Parshall flumes, ± 5 %.